

Electric Service Guide

Solar Photovoltaic

With Optional Energy Storage Systems



*Contact MID's Electric Engineering Department
(electric.standards@mid.org)
with any questions about this Service Guide.*

*Check MID's website (www.mid.org) "Electric Service Guide" for the
most current version of this Service Guide.*

*If you have any suggestions about improving this Service Guide,
please complete the form on the last page of this Guide and return
it to MID's Electric Engineering Department.*

USE CAUTION WHEN DIGGING TO AVOID BURIED ELECTRICAL CABLES

BEFORE DIGGING CALL
USA (Underground Service Alert)
1 (800) 227-2600 or 811

Table of Contents

| | | |
|----|---|----|
| A. | Requirements for Solar Photovoltaic Systems..... | 1 |
| 1. | General | 1 |
| 2. | Equipment Certification..... | 1 |
| 3. | AC Disconnect Devices..... | 1 |
| B. | Abbreviations | 1 |
| C. | Frequently Asked Questions | 2 |
| D. | Definitions | 2 |
| 1. | PV System | 2 |
| 2. | Energy Storage System (ESS) | 2 |
| 3. | Smart Contactor..... | 2 |
| E. | Grid Interconnection | 3 |
| | Electrical Interconnection Agreement and Net Metering Agreement | 3 |
| F. | Solar Project and or ESS Approval and Installation Procedure | 4 |
| G. | Solar Placarding Requirement..... | 5 |
| H. | Gate/Fence Accessibility Issues..... | 5 |
| I. | Required Documentation..... | 9 |
| J. | Local Governing Authorities Within MID’s Service Area..... | 10 |
| K. | MID Contact Information | 10 |

List of Attachments

| | |
|--|----|
| Figure 1: Caution PV and Utility Power Placard..... | 7 |
| Figure 2: Solar Array AC Disconnect Placard..... | 7 |
| Figure 3: Utility Use Only AC Disconnect Placard | 7 |
| Figure 4: Solar Production Placard..... | 7 |
| Figure 5: Solar Breaker Placard | 8 |
| | |
| Drawing PV-001.0: Typical Residential Line Side Connection | 11 |
| Drawing PV-001.1: Typical Line Side Connection..... | 12 |
| Drawing PV-002.0: Typical Residential PV Connection | 13 |
| Drawing PV-002.1: Typical Residential PV Connection with Sub-Panel | 14 |
| Drawing PV-003.0: Typical PV Equipment Layout..... | 15 |
| Drawing PV-003.1: Typical Residential PV Connection with Customer Meter | 16 |
| Drawing PV-004.0: AC Disconnect and Production Meter Wiring | 17 |
| Drawing PV-005.0: Net Metering Wiring & Meter Installation..... | 18 |
| Drawing PV-006.0: Sample Site Plan | 19 |
| Drawing PV-007.0: Sample Single Line Drawing | 20 |
| Drawing PV-008.0: Typical PV Equipment Layout (Vertical Installation) | 21 |
| Drawing PV-009.0: AC Disconnect and Production Meter Wiring (Vertical Installation) | 22 |
| Drawing PV-010.0: Single Phase Self-Contained Meters, Residential Service Working Clearance..... | 23 |
| Drawing PV-011.0: Solar PV Placarding Requirements | 24 |
| Drawing PV-011.1: Battery Storage Placard..... | 25 |
| Drawing PV-012.0: DG Interconnection with Battery (Option One) | 26 |
| Drawing PV-013.0: DG Interconnection with Battery (Option Two)..... | 27 |
| Drawing PV-014.0: DG Interconnection with Battery (Option Three) | 28 |
| Drawing PV-015.0: DG Interconnection with Battery (Option Four) | 29 |
| Drawing PV-016.0: DG Interconnection with Battery (Option Five) | 30 |
| | |
| Sample 1: Main Panel | 31 |
| Sample 2: Disconnect..... | 32 |
| Sample 3: Generation Socket..... | 33 |
| | |
| Form 1: Area Map | 34 |
| Form 2: Service Guide Customer Input..... | 35 |

A. Requirements for Solar Photovoltaic Systems

1. General

The Solar PV Handbook is available online at MID's website <https://www.mid.org/solar>. Information can also be obtained by emailing MID at pv@mid.org.

All solar photovoltaic systems and energy storage systems interconnected to MID's electric distribution system shall comply with the requirements, terms and conditions pursuant to the MID Solar Photovoltaic Program Handbook, MID's Electric Service Guide "Solar Photovoltaic" along with any local and state governing authority's requirements (see list of local governing authorities on page 10).

2. Equipment Certification

A nationally recognized testing laboratory must certify all flat plate solar electric modules and inverters. The modules must meet the requirements of the Underwriters Laboratories Standard 1703. The inverters must meet the requirements of the Underwriters Laboratory Standard 1741. The solar electric photovoltaic generation systems must use components that are listed on the California Energy Commission's (CEC) list of "Eligible Equipment" as found on the CEC's website.

3. AC Disconnect Devices

All solar electric generation systems are required to have an alternating current, full load break disconnect switches with a lockable handle. The handle shall be capable of locking in the open position and the switch contacts must provide a "visible open." This requirement assures that no electricity can back feed into the service panel which could result in personal injury or damage to the equipment. MID must be able to isolate the electric meter(s) to perform maintenance in a safe manner.

B. Abbreviations

The following abbreviations may be used throughout this Service Guide.

| | |
|-----|------------------------|
| AC | Alternating Current |
| Amp | Amperes |
| DC | Direct Current |
| DG | Distributed Generation |
| ESS | Energy Storage System |
| GO | General Order |
| kW | Kilowatt |
| PV | Photovoltaic |
| SB1 | Senate Bill 1 |
| SLD | Single Line Diagram |
| V | Volt |
| W | Watt |

C. Frequently Asked Questions

1. *What is a photovoltaic system?*

Photovoltaic (PV) systems are an arrangement of components designed to supply usable electric power using the Sun as the power source.

2. *How do solar panels work?*

Solar panels are composed of many PV cells, which are comprised of a semiconductor material such as silicon. Added to the silicon are the elements phosphorous and boron, which create conductivity within the cell and activate the movement of electrons. The electrons move across the cell when activated by the sunlight's energy into the electrical circuit hooked up to the solar panel.

3. *How do I wire a Production Meter?*

Please refer to Drawing PV-004.0 (page 17).

4. *How much maintenance do solar energy panels require?*

Consult the manufacturer for recommended maintenance.

D. Definitions

1. **PV System**

PV power systems convert sunlight directly into electricity. Since the electricity produced is Direct Current (DC), an inverter is used to convert the DC to Alternating Current (AC). The customer can then use the generated electricity to serve some or all of the energy demands and sell the excess energy to the electric utility via a bi directional meter also known as net metering. PV system must comply with MID's Rule 21.

2. **Energy Storage System (ESS)**

Energy Storage System (ESS) is a system that uses either chemical means or mechanical means to store energy for later use. The system will include all equipment necessary to convert the stored energy into useable energy.

3. **Smart Contactor**

A Smart Contactor is a device that will automatically disconnect an ESS from the host electric utility upon detection of voltage or frequency abnormality. It will reconnect to the system once the abnormality has passed. Refer to Rule 21 section F for operating limits and tripping parameters. A Smart Inverter's operating limits apply to a Smart Contactor.

E. Grid Interconnection

All grid-connected PV system and ESS must comply with all applicable local and national electrical codes as well as MID interconnection requirements stated in Rule 21 and Electric Service Rules.

The PV system must offset the customer's energy use by supplying electricity otherwise supplied by MID. MID requires the installation of a Meter Socket on the AC side of the inverter. MID will install a utility grade production meter that will allow MID to measure the generation output of the PV system (see Sample 3: Generation Socket).

MID also requires the installation of two visible, lockable AC disconnect switches to be installed between the PV system and the MID Distribution System. The switches must be visible and clearly labeled. The first AC disconnect should be located between the electric panel and the production meter socket. Refer to Drawing PV-011.0 for strictly solar solutions. For PV with an ESS refer to Drawing PV-012.0 through Drawing PV-016.0.

The AC disconnect directly adjacent to the main electric panel and the production meter socket must be installed within 12 feet and within line of site of the main electric panel in a readily accessible location. The production meter on PV systems is intended to be in place for the duration of its useful life.

All ESS solutions shall be configured to provide backup power for the customer in case of an outage or peak shaving only. ESS shall not be configured to export power back onto MID's system.

Line side connections, the connection between the meter and the main disconnect (breaker), will be allowed as long as the installation meets the requirements of the National Electric Code, does not void the warranty of the service panel, does not void the listing of the service panel by a Nationally Recognized Testing Laboratory (NRTL), and does not prevent the standard operation of the service panel (see Drawing PV-001.0, page 11).

Any installations that involve field modifications to the service panel, not designed by the manufacturer, may void the NRTL listing on the service panel. This will require the service panel to be re-listed by a NRTL (e.g., UL, E.T.C., etc.). If the service panel has to be re-listed, contact MID Energy Services at MIDPhotovoltaicProgramDropboxMail@mid.org or call (209) 526-7582.

Please contact your local Engineering Technician for approval before purchasing or installing any equipment. See the Area Map (page 34) for your local Engineering Technician's contact information.

Systems must be secured to a permanent surface. Any indication of system portability may deem the system ineligible for program incentives and connection to the MID system.

Electrical Interconnection Agreement and Net Metering Agreement

Customers installing a solar PV system and customers requesting service at an existing service with a solar PV system are required to submit an Electrical Interconnection Agreement (see www.mid.org/tariffs/) and the appropriate Net Metering Agreement (see www.mid.org/tariffs/). Customers modifying an existing solar PV system are required to submit new Interconnection and Net Metering Agreements for approval prior to interconnection with MID.

The Electrical Interconnection Agreement allows the customer to interconnect their generating system with the MID electric system. MID reserves the right to inspect and verify all interconnected systems at any time.

F. Solar Project and or ESS Approval and Installation Procedure

1. The contractor (or customer) submits a completed application package to MID's Energy Services Department. A list of the required documents can be found on the "Handbook" link on the MID solar webpage on MID's website (www.mid.org).
2. MID will review the submitted application package to insure that all required documents are enclosed and complete. Of particular importance is the submitted single-line and plan view drawings (see page 9 for important details that must be included in these documents). It can take up to 30 days for the review to be completed.
3. The contractor and/or customer will be sent either:
 - a) An approval letter indicating that the project has been approved and authorizing the customer to start construction; or
 - b) An email requesting the necessary revisions, corrections and/or documentation to meet MID's requirements.
4. If main panel replacement (referred to as a "rewire") is necessary, contact an MID Engineering Technician (phone numbers are listed on the Area Map on page 34).
5. Once the project has been completed and inspected by the local governing authority (see list on page 10), MID's receipt of the final, signed-off permit initiates the necessary MID Interconnection Inspection. This should be emailed to the pv@mid.org email address with the customer name and address in the subject line. Interconnection inspections are conducted by the MID Meter Department. In order to conduct the inspection, MID must have access to the customer Main Service Panel and required MID PV devices (AC disconnects and generation meter socket). Typically, the customer need not be home for this inspection. However, if an appointment is necessary with the customer to allow access to equipment, this must be requested at the time when the final permit is submitted to MID. A customer or contractor phone number should be provided so that an appointment can be arranged. Interconnection inspection can take up to 10 business days. Customers with both PV and ESS will need to schedule an appointment for the inspection.
6. If the PV installation meets MID requirements and is "passed," a generation meter will be set. At this point the PV system may be energized. NOTE: MID will NOT energize PV systems. If issues are found and the inspection is "failed," an email will be sent to the contractor and customer indicating the issues found and corrections necessary. Once the issues are corrected, he contractor/customer must reply to the failed inspection notice requesting an interconnection re-inspection. Note that re-inspection fees will apply for all failed inspections. Refer to Appendix A of the MID Electric Service Rules for more information.

7. Once a PV system interconnection inspection has “passed,” MID will send a formal PTO (Permission To Operate) letter to the customer. The contractor will be emailed a copy. This typically occurs within about a week of a passed inspection.

G. Solar Placarding Requirement

The identifying markings for **all required PV and ESS equipment** shall be impressed into or raised from a tag of Plastic Laminate, aluminum, brass or other non-ferrous metal with a minimum of ¼” letters.

The impressions shall be deep or raised enough to prevent it from being obscured by subsequent painting of the service sections.

The tags shall be attached to a non-removable area of the panel, with a high strength, 5-minute epoxy adhesive. Other types of adhesives (such as rivets, screws) will not be acceptable. The tag shall not be able to be removed without the use of hand tools. Refer to Drawing PV-011.0 through Drawing PV-016.0 for required text and placement.

H. Gate/Fence Accessibility Issues

MID requires PV devices (the AC disconnects and generation meter) to be located in proximity to the customer’s main panel - generally all within about a 12’ span and in line of sight. On homes where the customer’s Main Service Panel (MSP) is on the side of the home, it is important and required that a side gate or fence does not separate the MSP, AC Disconnect, and Generation Meter Socket. In other words, ALL devices should be on the same side of the gate/fence.

However there are situations, often due to the location of a PG&E gas meter or where limited space is available, where the MSP and the required PV devices must be separated and located on the opposite side of a fence or gate. In such cases, an exception may be granted and MID must be informed PRIOR to the installation. This should be noted on the submitted Plan View drawing so MID can review the situation and confirm that an exception is necessary. If MID approves of the separation of devices and MSP, an additional placard will be required indicating the location of the MSP relative to the AC disconnection and generation meter socket. Most often a simple placard must be installed on the MSP indicating “required MID PV devices are located on the opposite side of adjacent gate.”

MID requires reasonable access to the MSP as well as the required AC disconnects and generation meter not only at the time of the Interconnection Inspection, but on an ongoing basis. If any of these items are located behind a gate that is normally locked, the customer or contractor must provide either a dual lock hasp or the installation of an MID keyed lock at the time of the inspection. Note that dual lock hasps are available at many electrical supply outlets. Hoffman makes a Dual-Access Safety Lockout which is manufactured from 10 gauge steel with .38-inch (10mm) diameter padlock holes. The padlocks are not included. Such device would accept a customer lock as well as an MID-supplied and keyed lock. Alternately, a single MID keyed lock can be purchased and installed. These locks have a unique key to which MID has the master. These locks can be procured from AI’s Certified Safe and Lock (209) 524-9181 located at 4900 Elm Street, Salida, or from Easy Locks (209) 380-8255.

MID can arrange an appointment with either the customer or the contractor for the Interconnection Inspection if necessary due to pets or simply an interest to observe the process. The PV contractor must advise MID of this request at the time the final permit is submitted to MID. The full name and contact phone number of the individual requesting the appointment with MID must be included in the email that submits the final, signed-off permit to MID. MID will call to arrange the inspection at a mutually agreeable date and time.

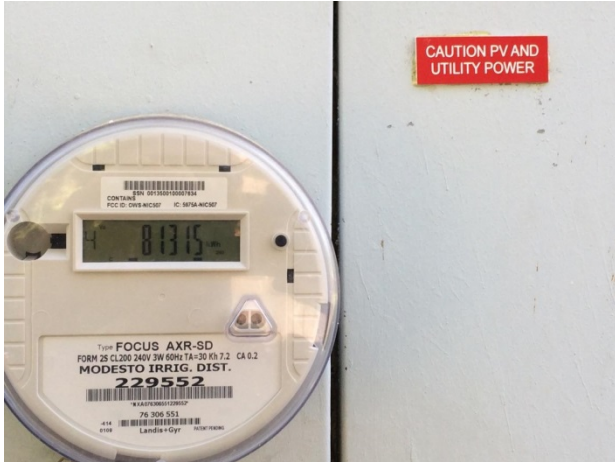

Figure 1: Caution PV and Utility Power Placard



Figure 3: Utility Use Only AC Disconnect Placard



Figure 2: Solar Array AC Disconnect Placard



Figure 4: Solar Production Placard

NOTE:
All sources of power must be clearly placarded.



Figure 5: Solar Breaker Placard

I. Required Documentation

1. Single Line Diagram must include: (see Drawing PV-007.0, page 20)
 - a) Main panel with Bus and Main breaker ratings indicated (see sample Main Panel, page 31).
 - b) Interconnection breaker rating (breaker to be located at opposite end of bus bar from main breaker).
 - c) Both AC Lockable Knife Blade Disconnects.
 - d) Generation Socket with Listed Ratings (minimum NEMA 3R and UL414 listed).
 - e) Inverter(s) either Central or Micro-Inverters.
 - f) Inverter must be noted as “Grid Supported Utility Interactive Inverter.”
 - g) Smart Contactor with ratings if applicable.
2. Site Plan must include: (see Drawing PV-006.0, page 19)
 - a) Property Lines and Street Names including Full Addresses
 - b) Solar Panel Layout
 - c) Location of Main Service Panel
 - d) Locations of Both AC Disconnects
 - e) Location of Production Meter Socket
 - f) Location of Central Inverter (if applicable)
 - g) Location of any Locked, Unlocked Gates or Fences.
 - h) Locations and verbiage of placards (see placarding samples on page 7).
 - i) Site plan must be a drawing and not a photo.
3. AC Disconnect Cut Sheets (see sample Disconnect, page 32).
4. Production Meter Socket Cut Sheets (see sample Generation Socket, page 33).
5. Line Side Connection Detail (if applicable, contact MID’s Engineering Department).
6. For CT-rated projects, include proper EUSERC drawings and cutsheets at time of submittal.
7. Inverter Cut Sheets
8. Smart Contactor Cut Sheets

J. Local Governing Authorities Within MID's Service Area

City of Modesto Building Department

1010 Tenth St. 3rd Floor
Modesto, CA 95353
Phone: 209-577-5232

City of Waterford Building Division

101 E St.
Waterford, CA 95386
Phone: 209-874-2328
Fax: 209-874-9656

Stanislaus County Building Department

1010 Tenth St. Suite 3500
Modesto, CA 95354
Phone: 209-525-6557
Fax: 209-525-7759

City Of Oakdale Community Development

455 S. Fifth Ave.
Oakdale, CA 95361
Phone: 209-845-3625
Fax: 209-848-4344

San Joaquin County Building Department

1810 Hazelton Ave.
Stockton, CA 95205
Phone: 209-468-3121

City of Escalon Building Department

2060 McHenry Ave.
Escalon, CA 95320
Phone: 209-691-7460
Fax: 209-691-7439

City of Riverbank Building Department

6617 3rd St.
Riverbank, CA 95367
Phone: 209-863-7128

City of Ripon Building Department

259 N. Wilma Ave.
Ripon, CA 95366
Phone: 209-599-2613
Fax: 209-599-2183

K. MID Contact Information

Modesto Irrigation District

1231 Eleventh Street (P.O. Box 4060)
Modesto, CA 95354 (Modesto, CA 95352)
Electrical Engineering Department¹
Phone: 209-526-7468
Fax: 209-526-7357

¹ Contact the MID Engineering Technician assigned to the area (see map on page 34).

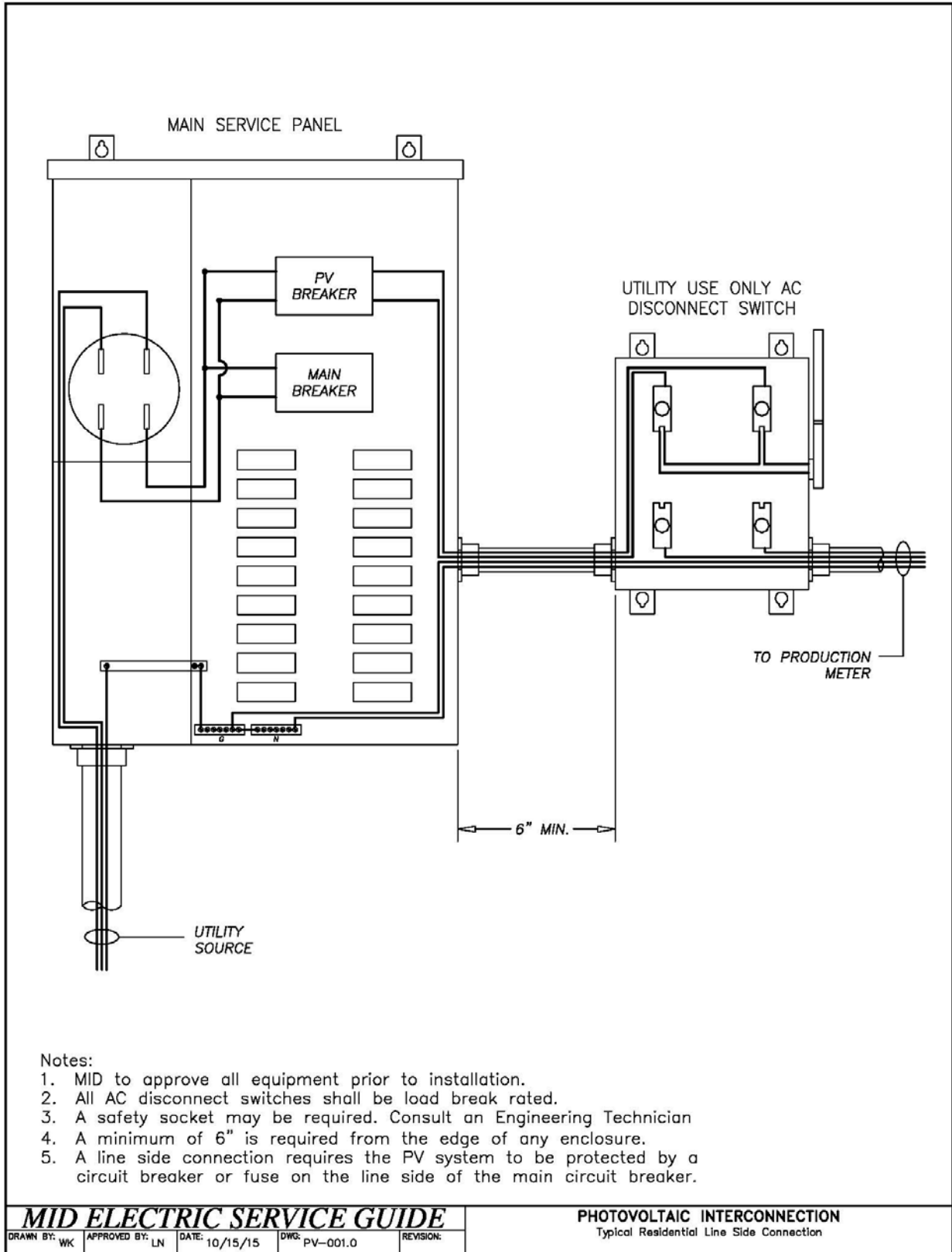

Drawing PV-001.0: Typical Residential Line Side Connection

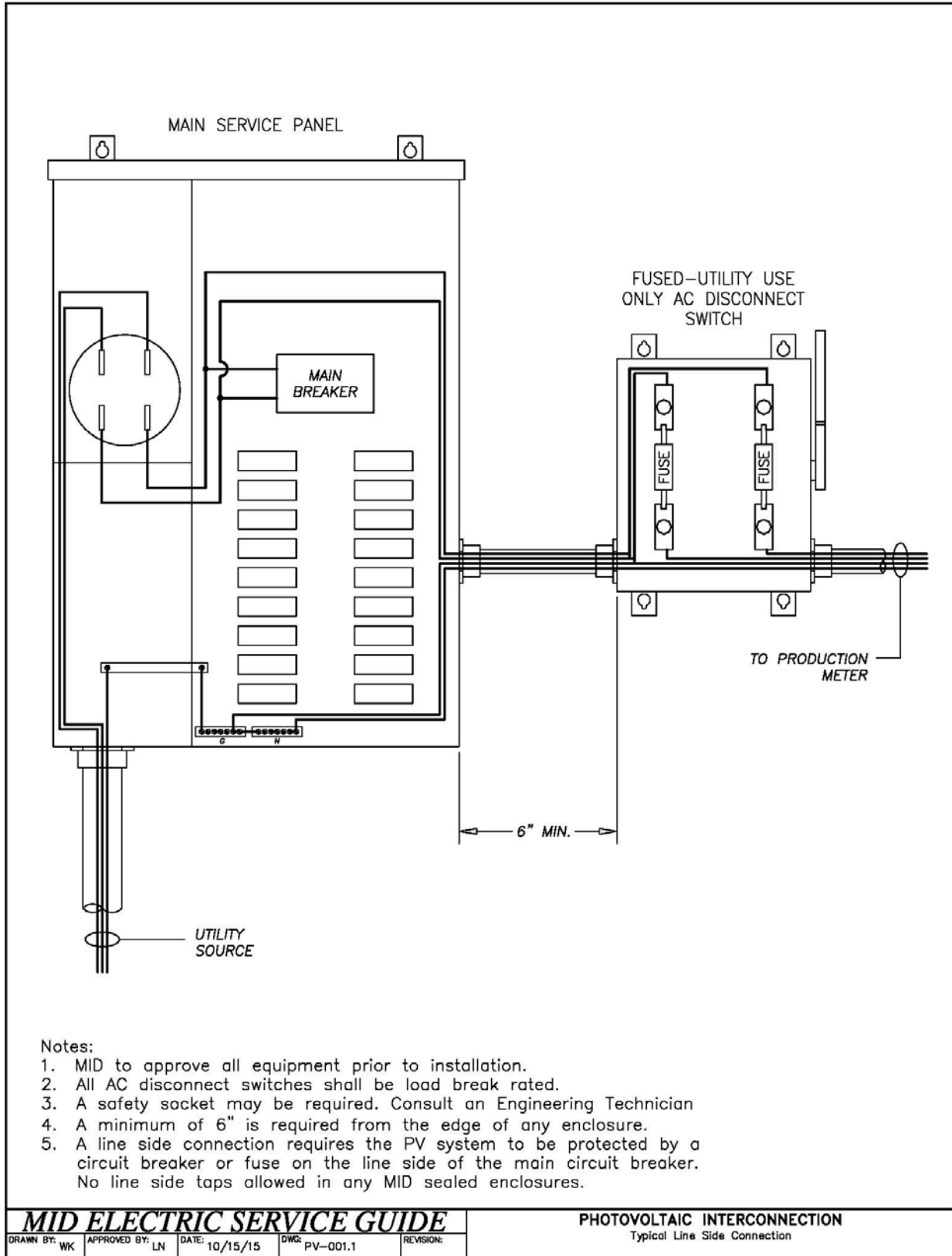

Drawing PV-001.1: Typical Line Side Connection

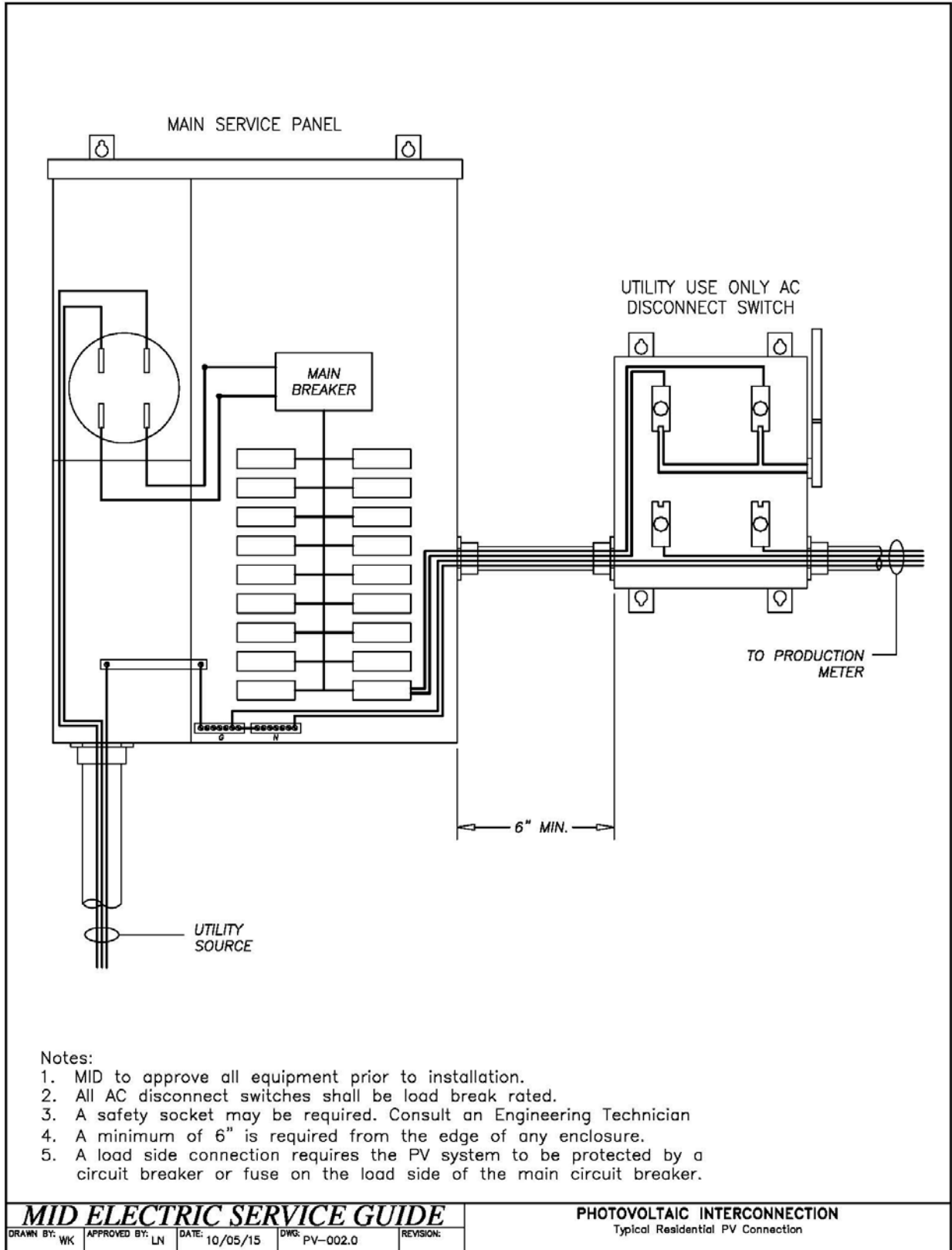

Drawing PV-002.0: Typical Residential PV Connection

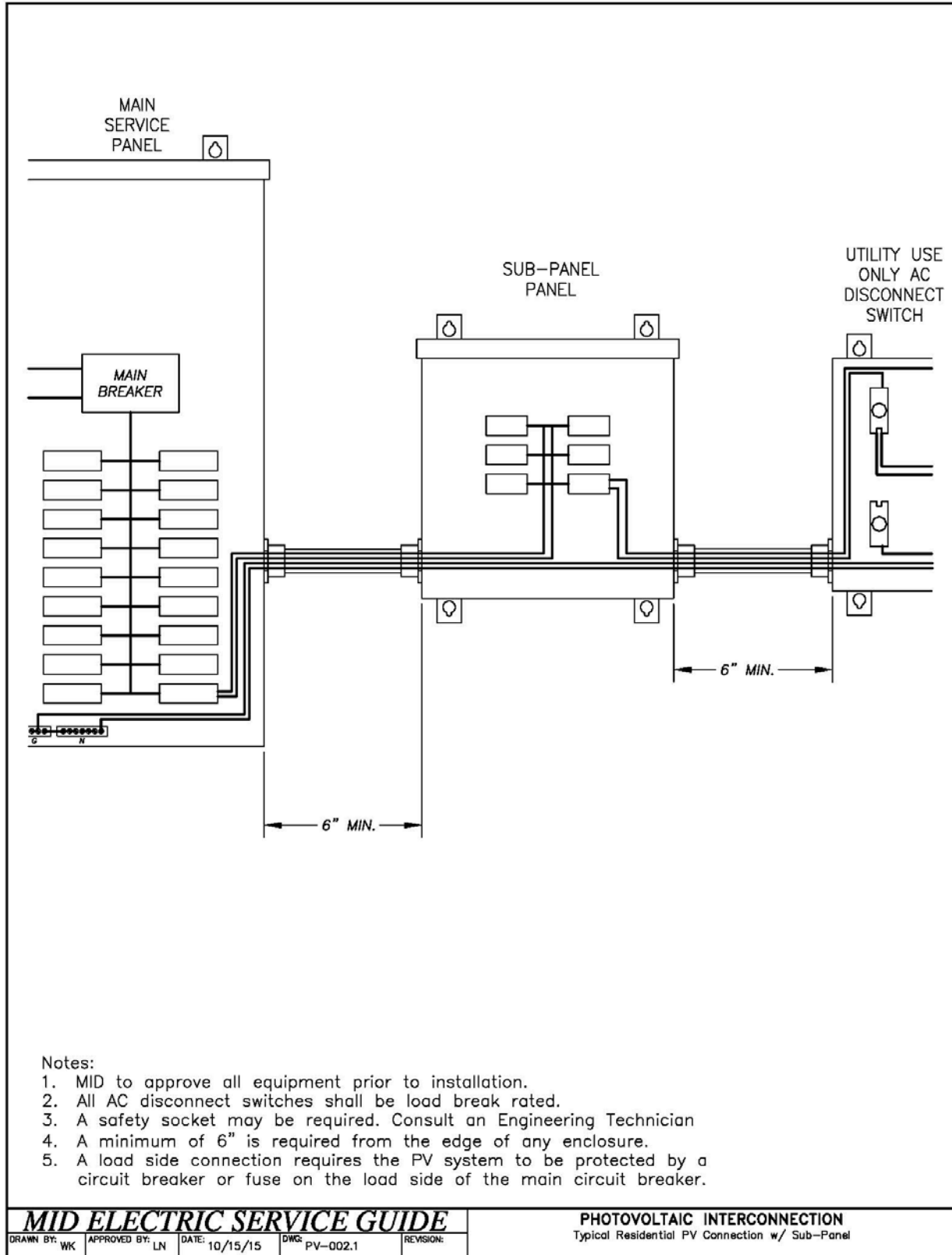

Drawing PV-002.1: Typical Residential PV Connection with Sub-Panel

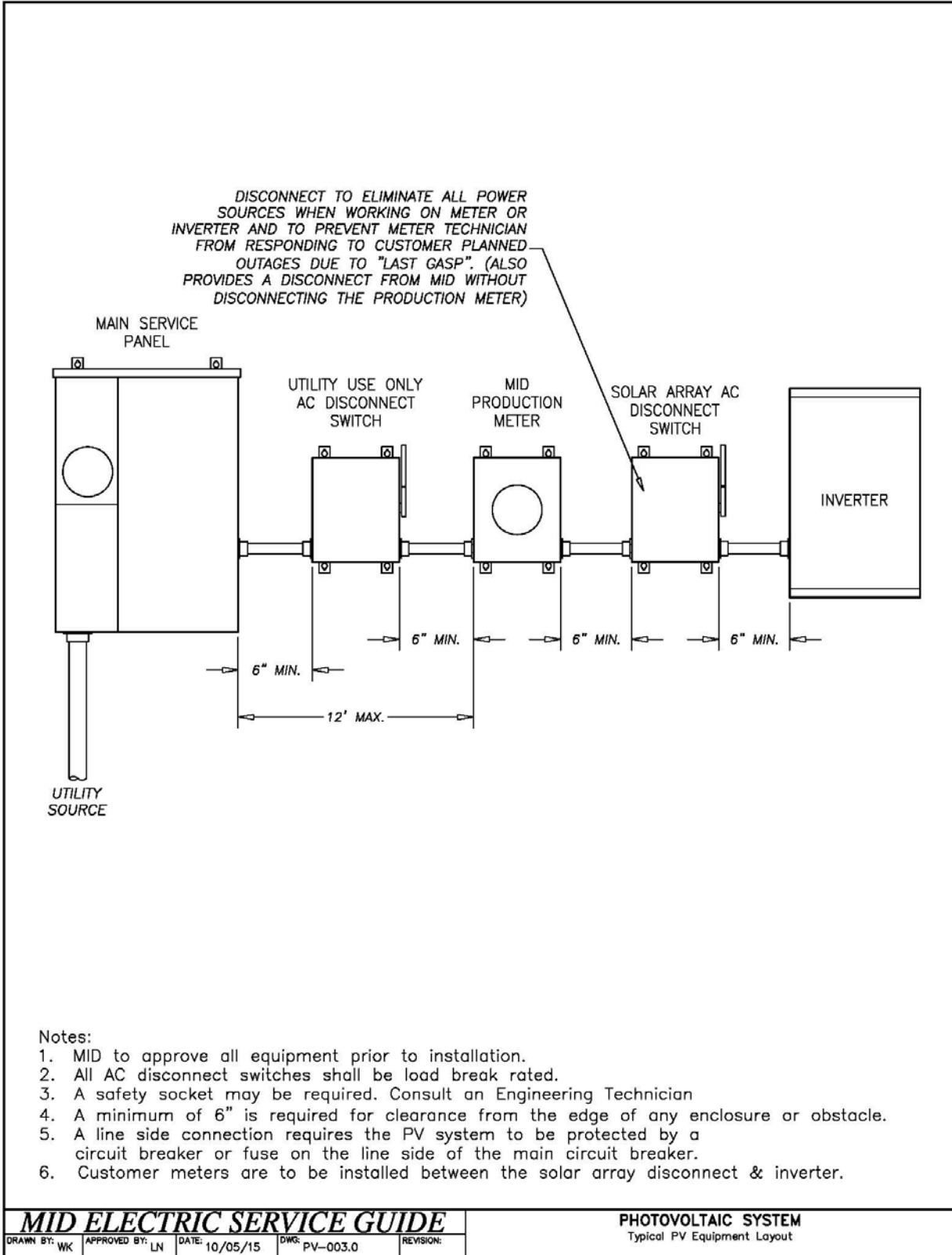

Drawing PV-003.0: Typical PV Equipment Layout

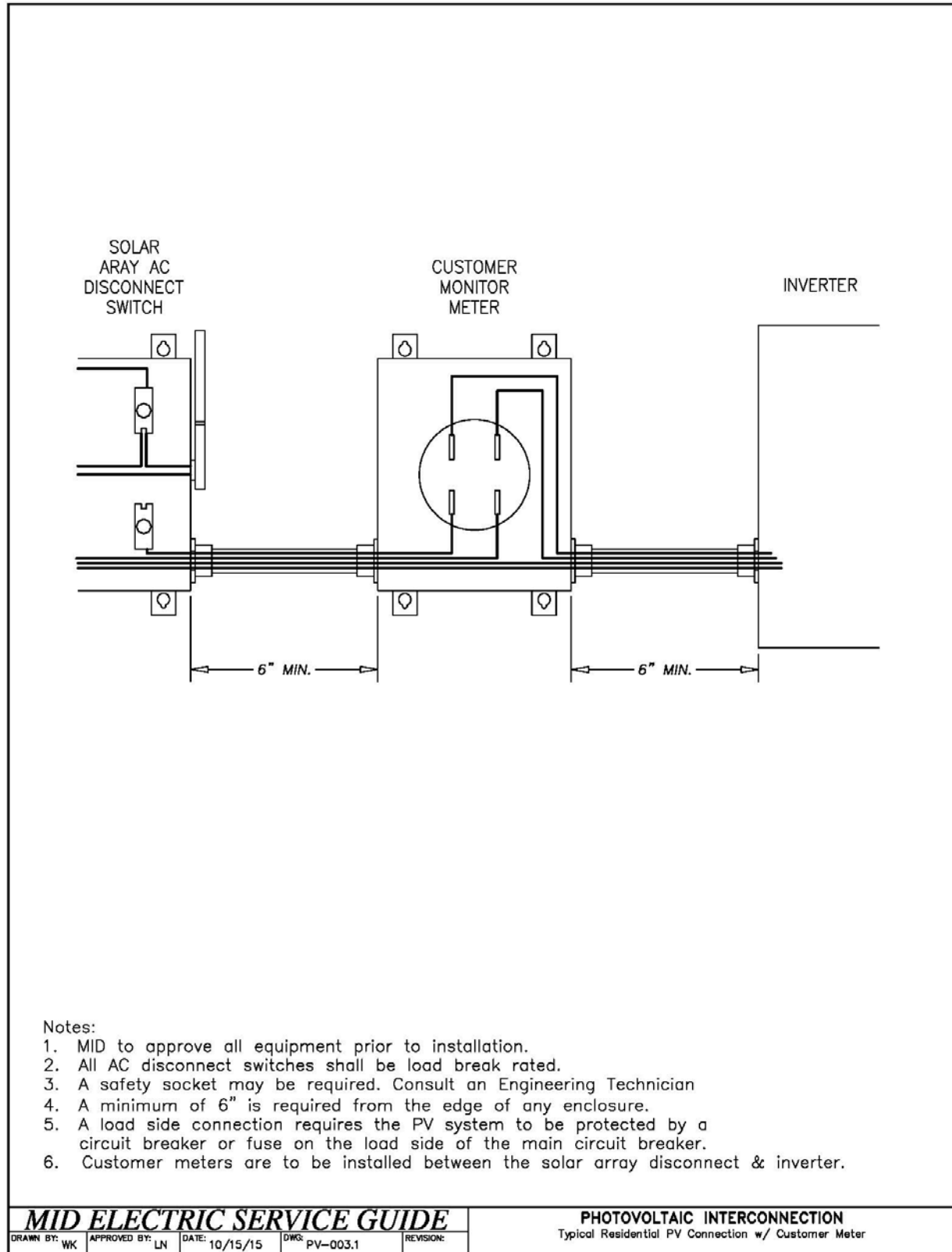

Drawing PV-003.1: Typical Residential PV Connection with Customer Meter

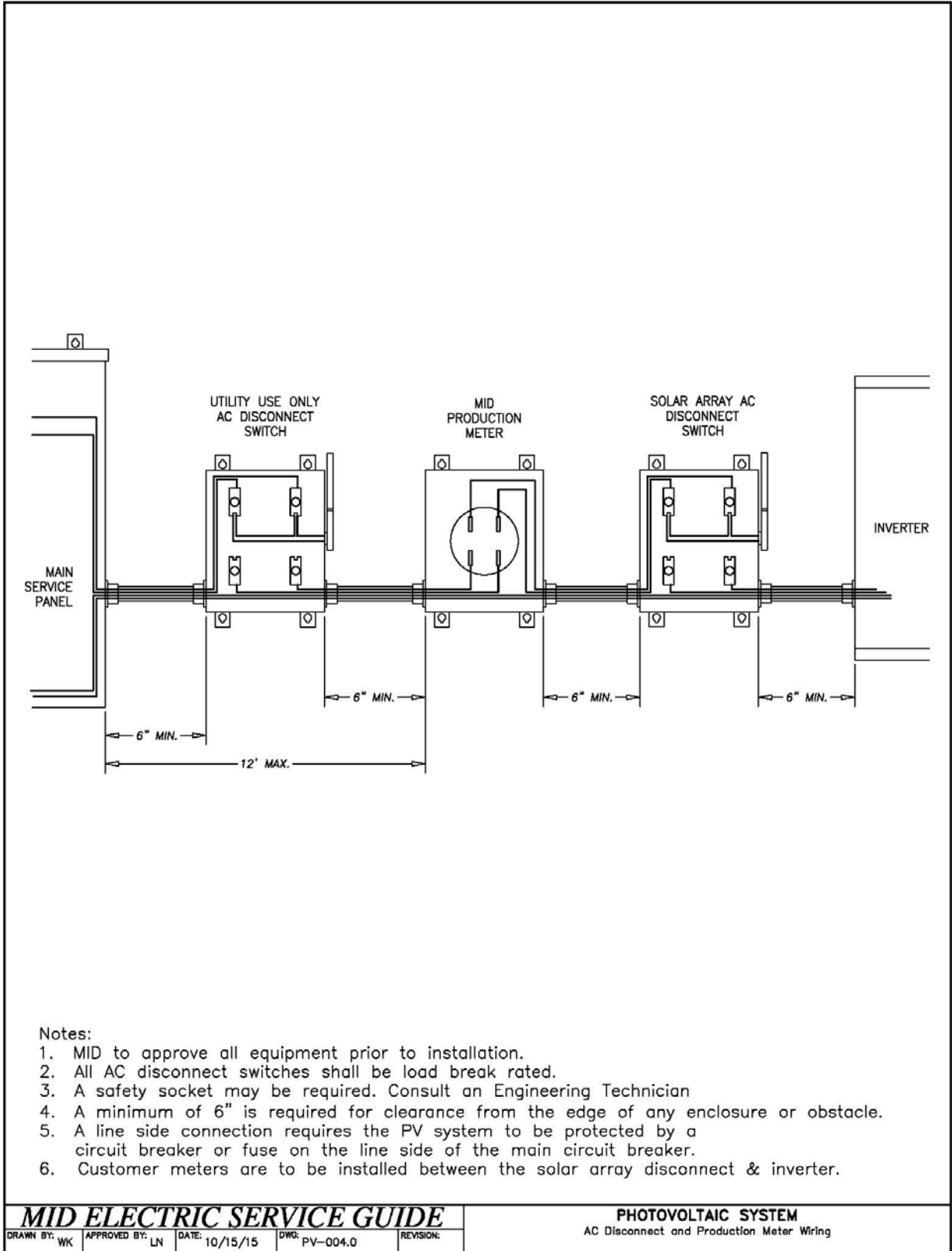

Drawing PV-004.0: AC Disconnect and Production Meter Wiring

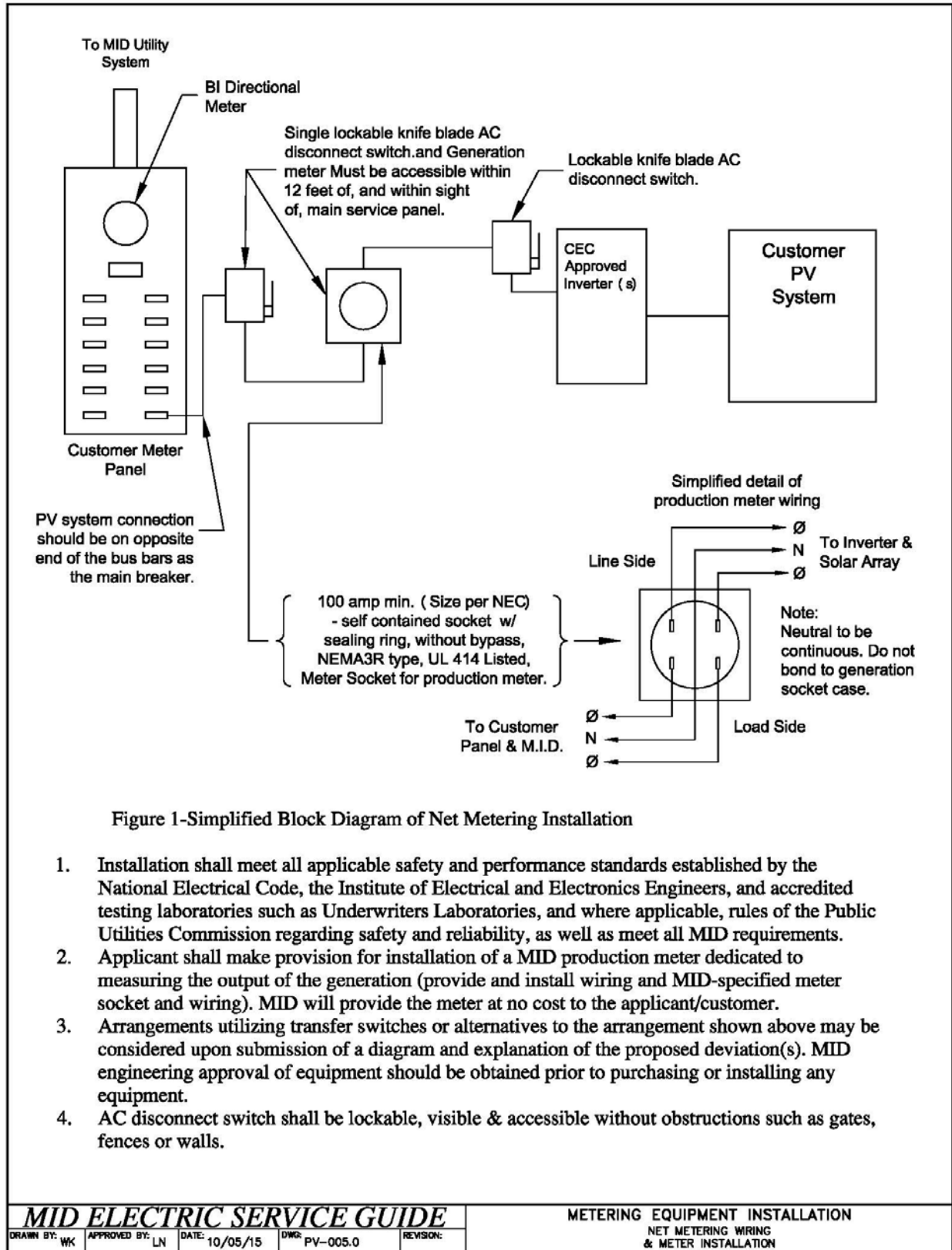

Drawing PV-005.0: Net Metering Wiring & Meter Installation

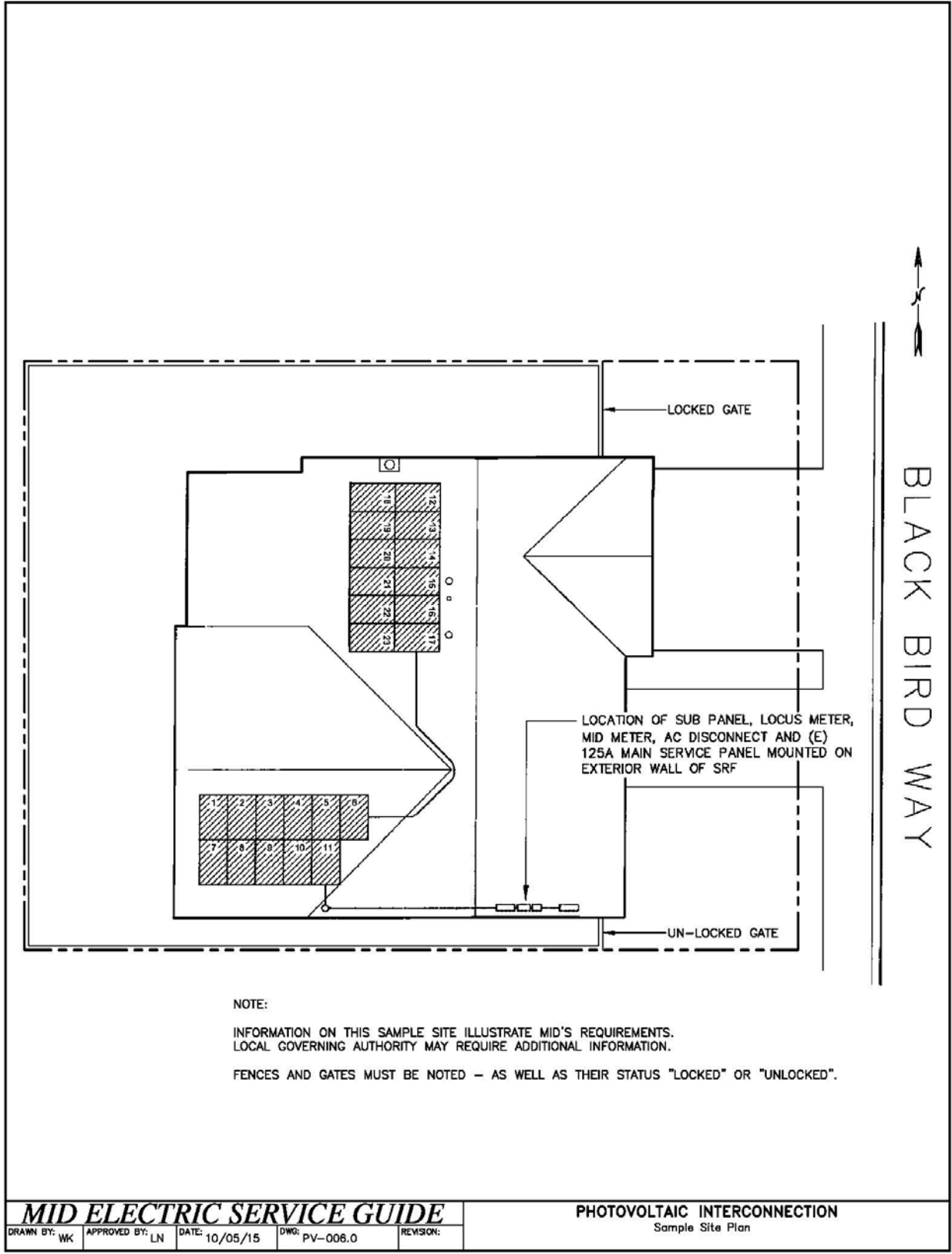

Drawing PV-006.0: Sample Site Plan

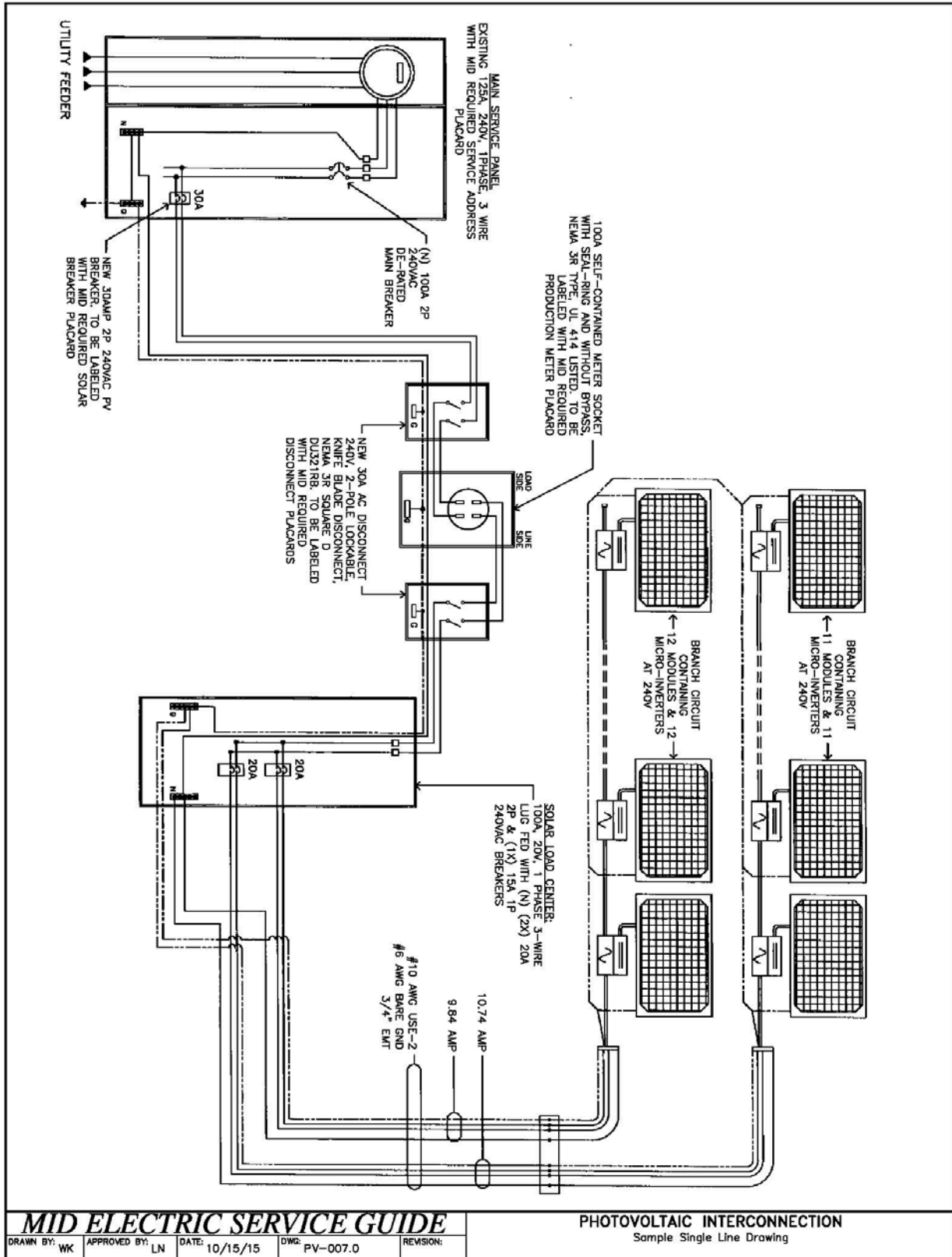

Drawing PV-007.0: Sample Single Line Drawing

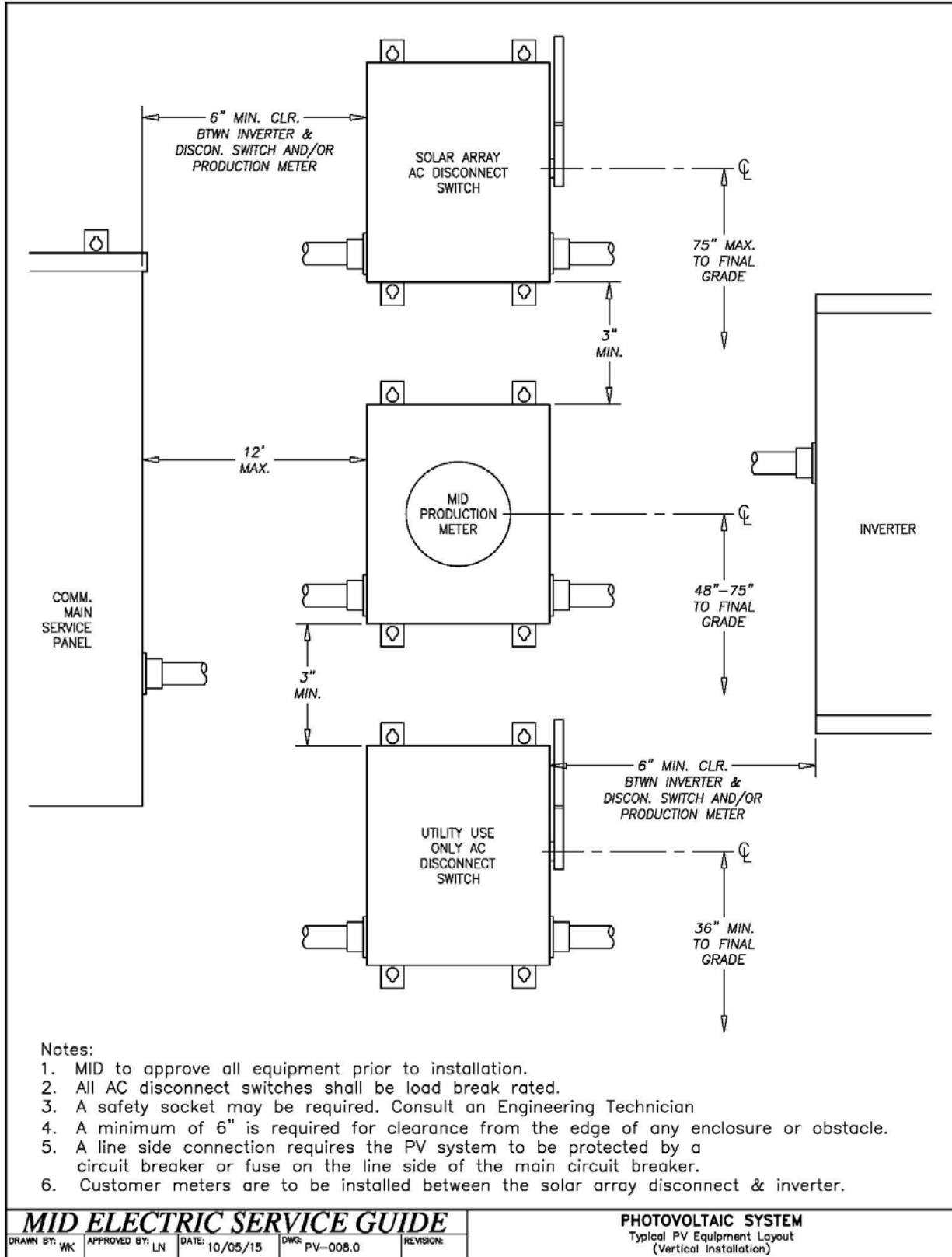

Drawing PV-008.0: Typical PV Equipment Layout (Vertical Installation)

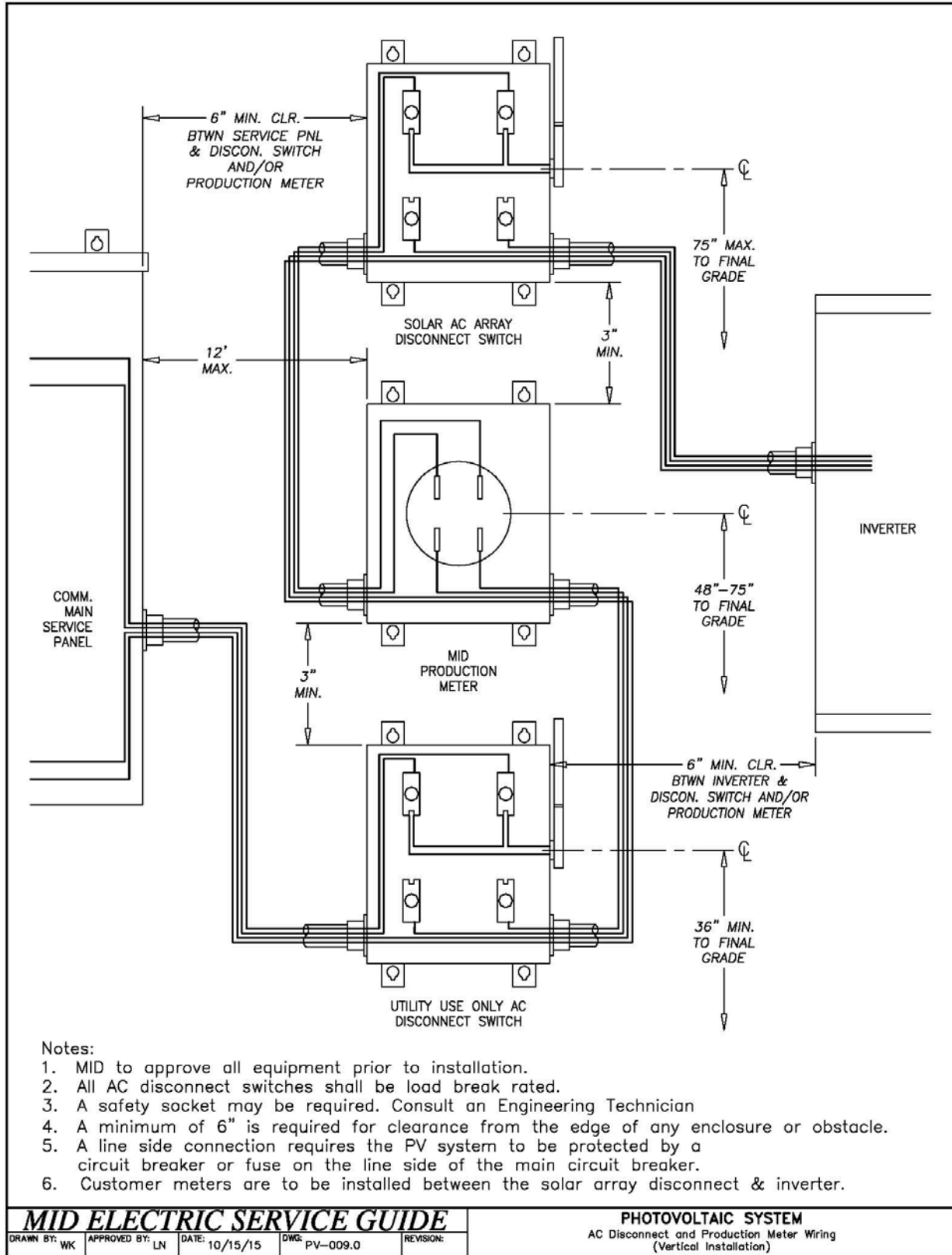

Drawing PV-009.0: AC Disconnect and Production Meter Wiring (Vertical Installation)

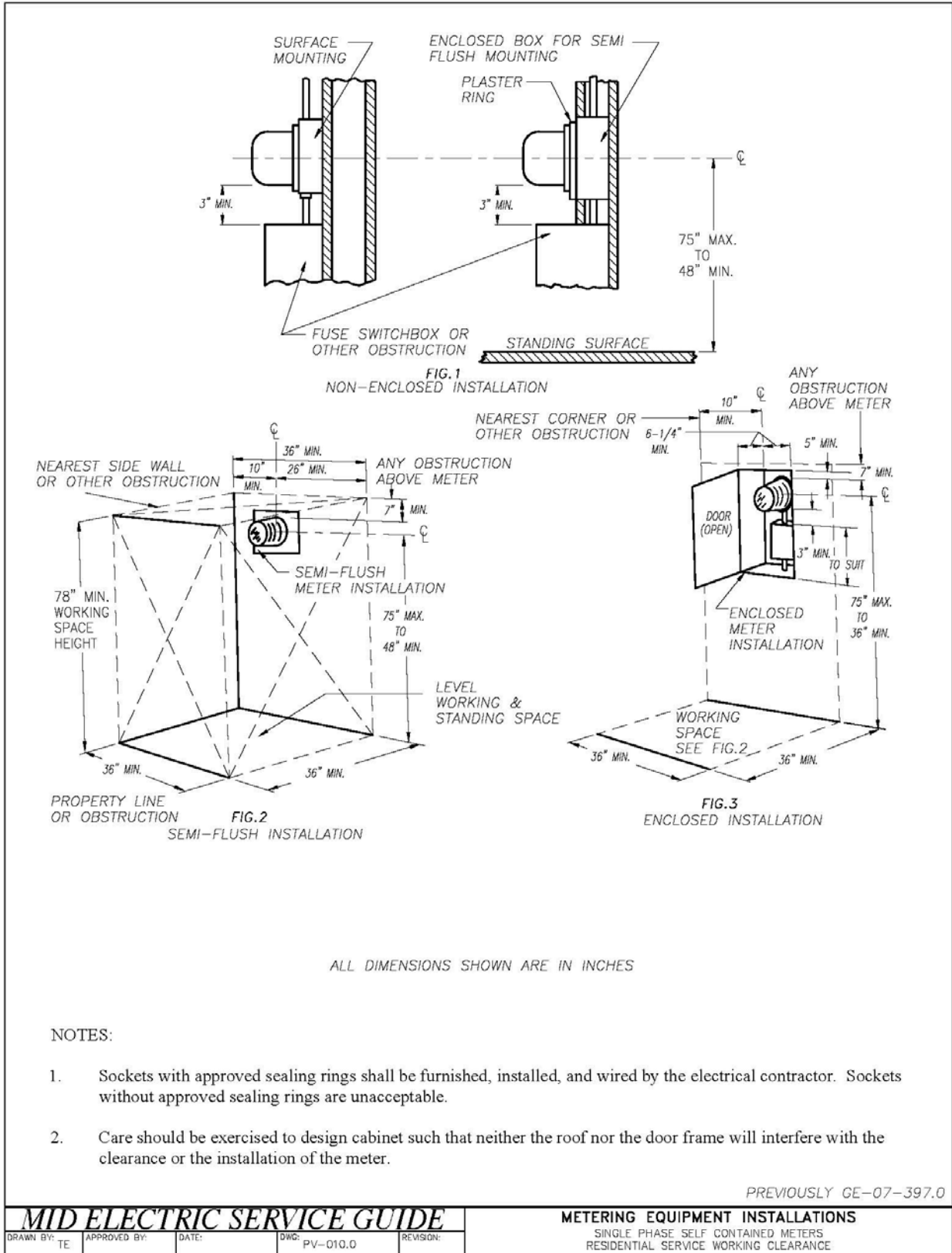

Drawing PV-010.0: Single Phase Self-Contained Meters, Residential Service Working Clearance

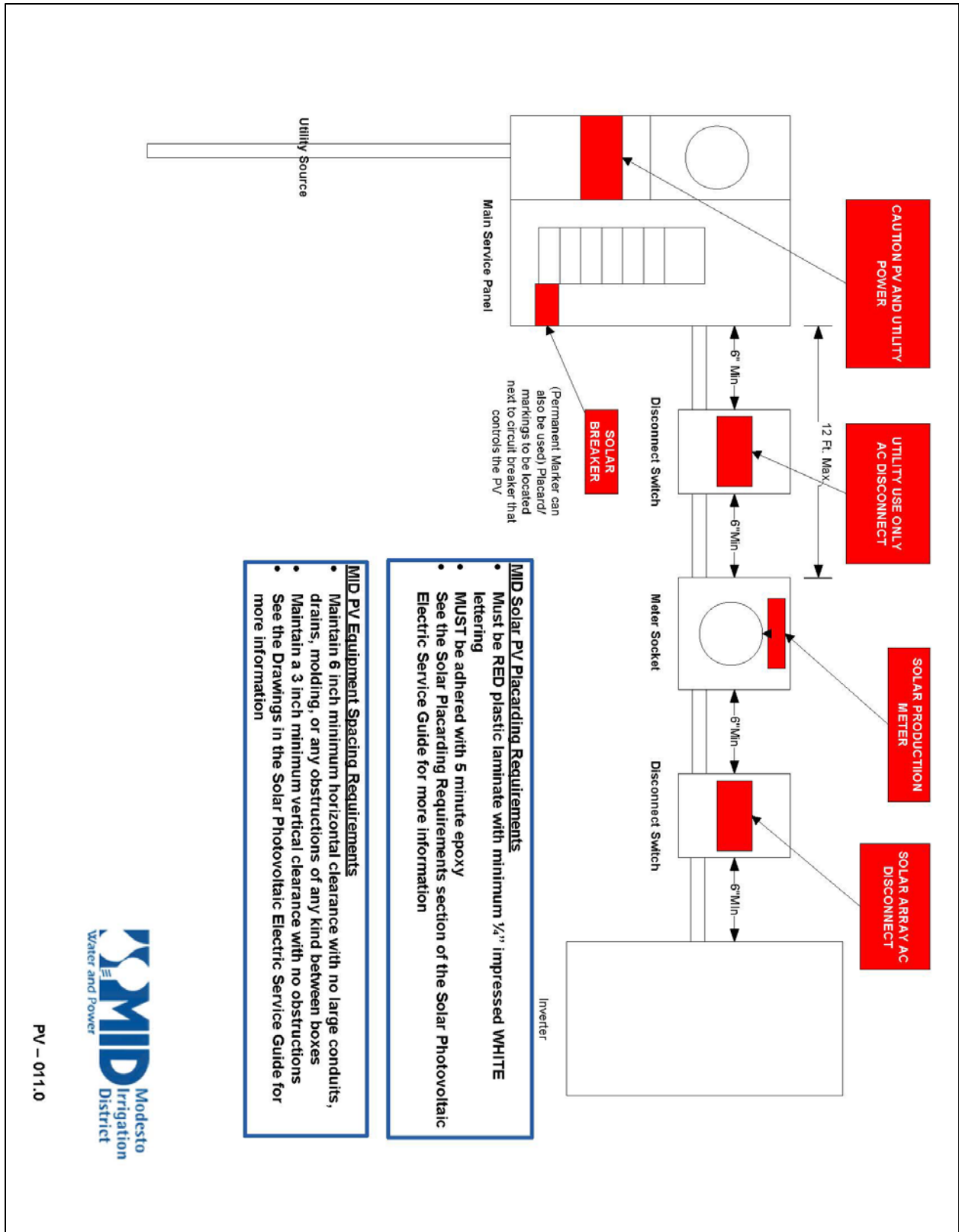

PV - 011.0

Drawing PV-011.0: Solar PV Placarding Requirements

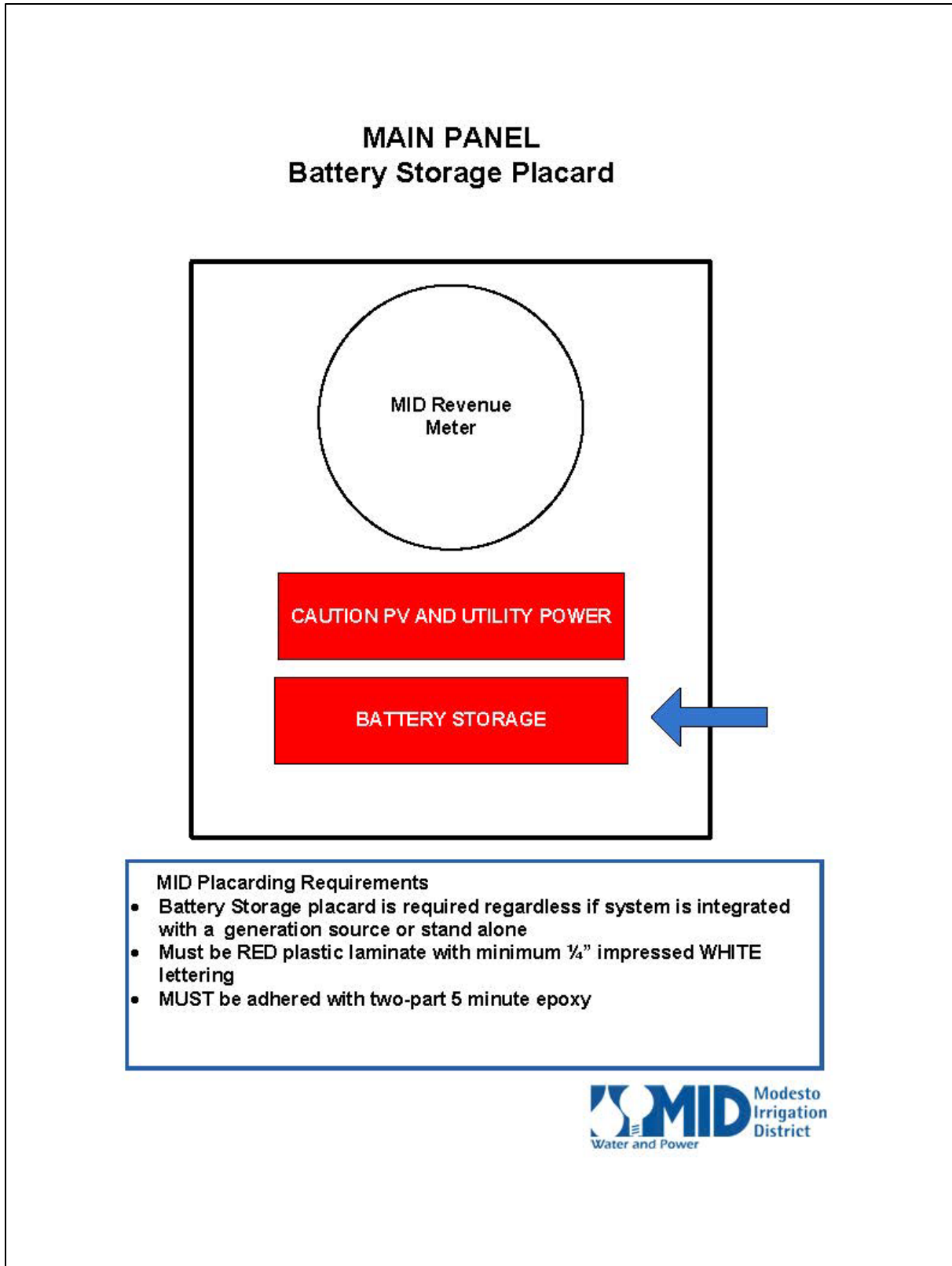

Drawing PV-011.1: Battery Storage Placard

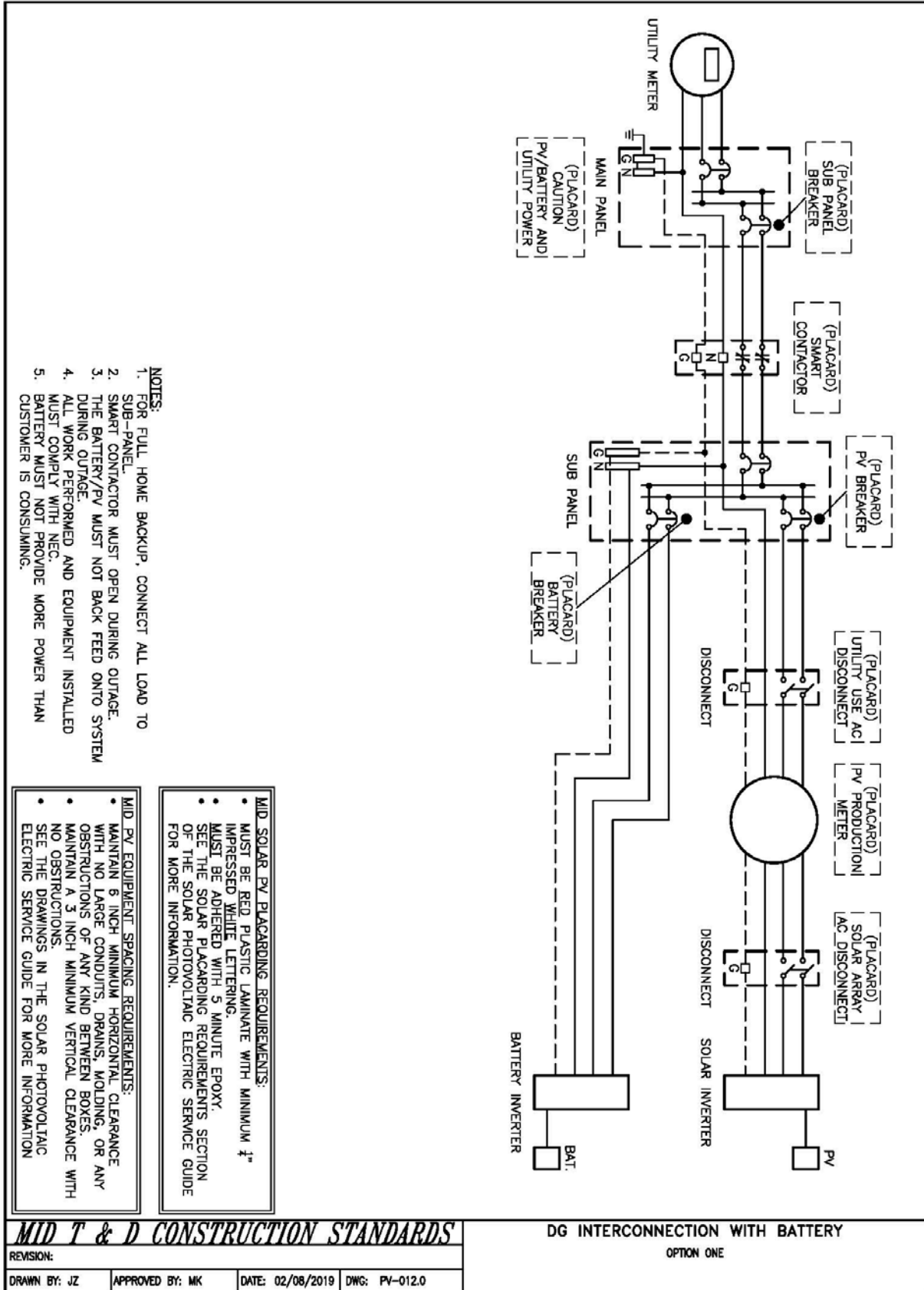

Drawing PV-012.0: DG Interconnection with Battery (Option One)

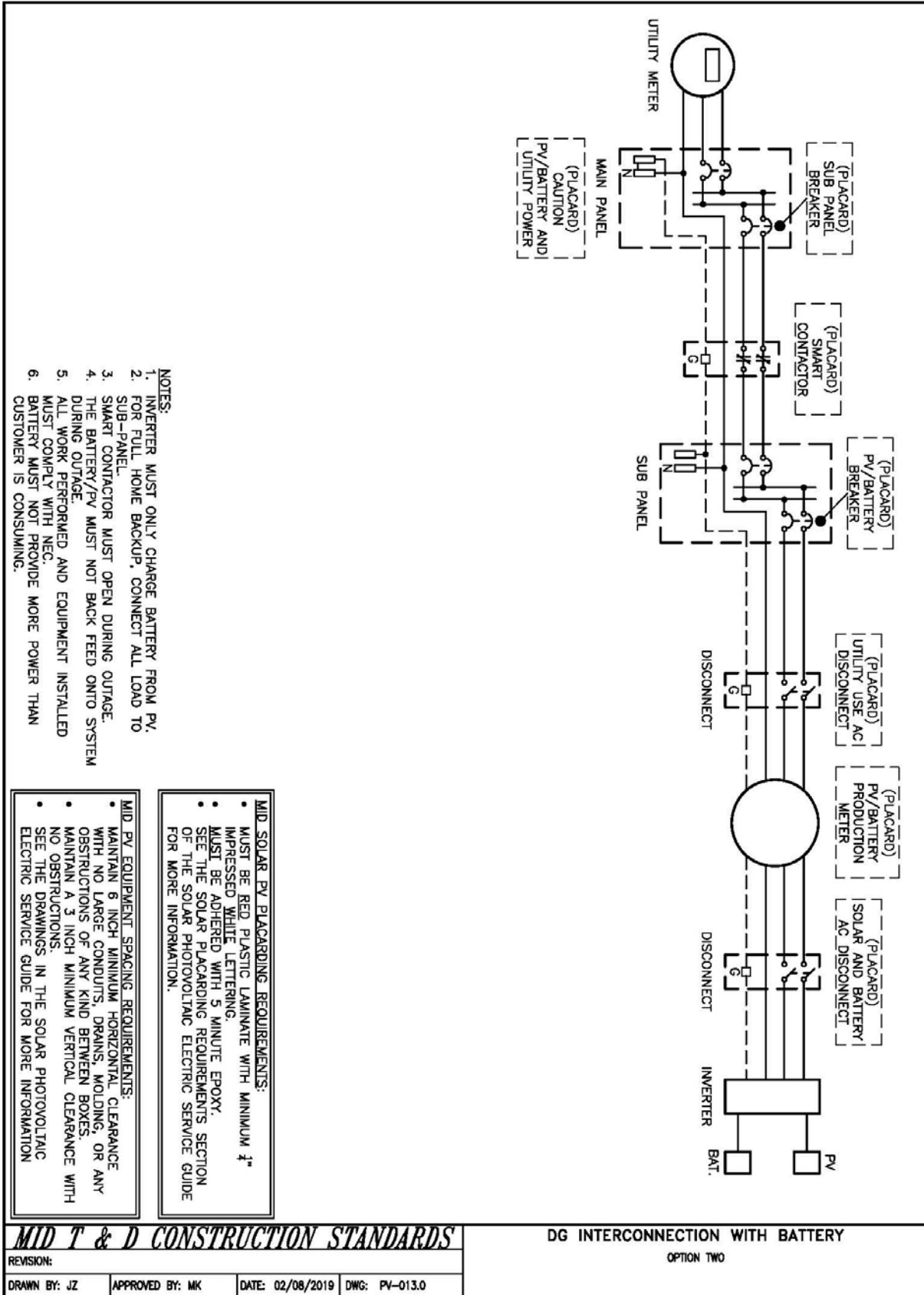

Drawing PV-013.0: DG Interconnection with Battery (Option Two)

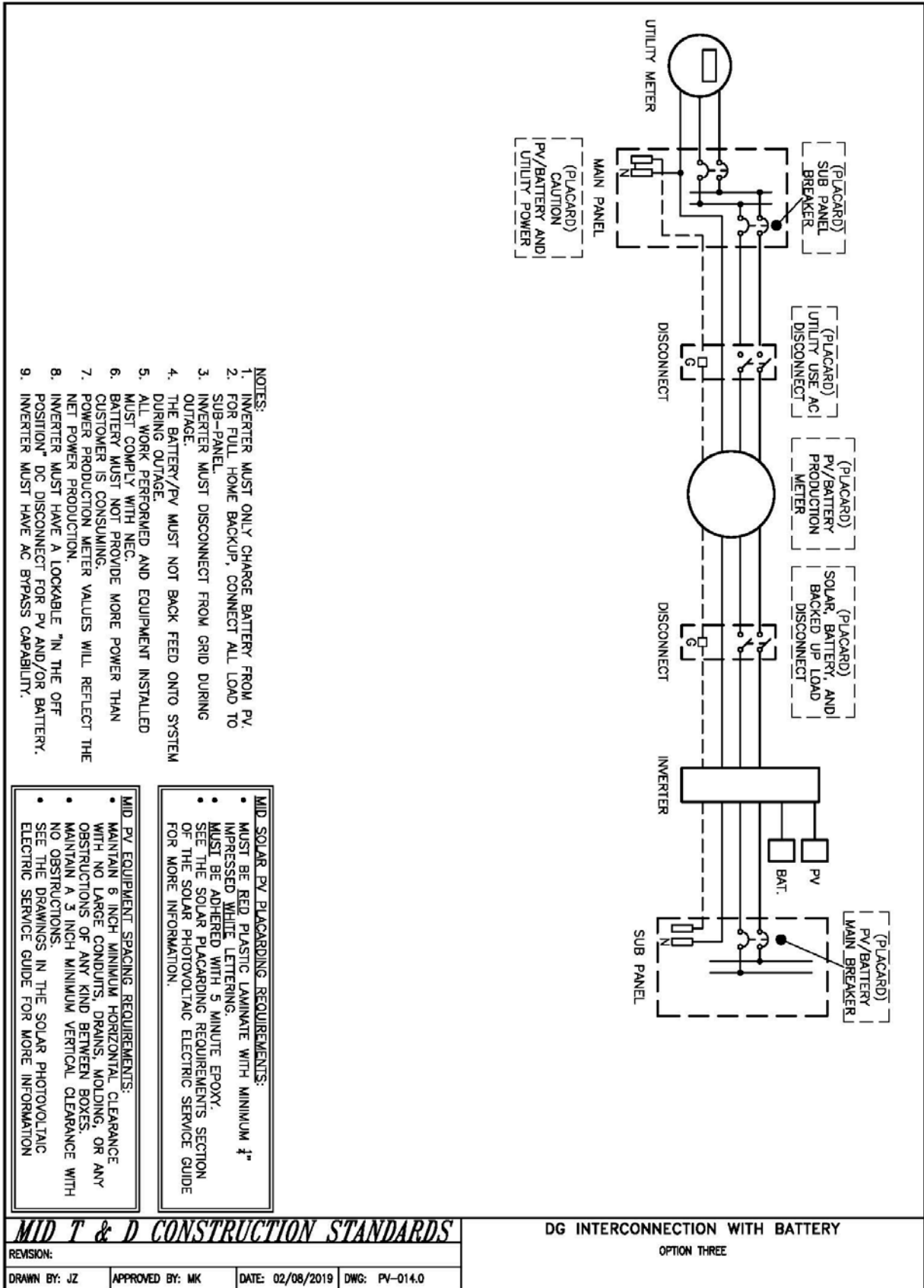

Drawing PV-014.0: DG Interconnection with Battery (Option Three)

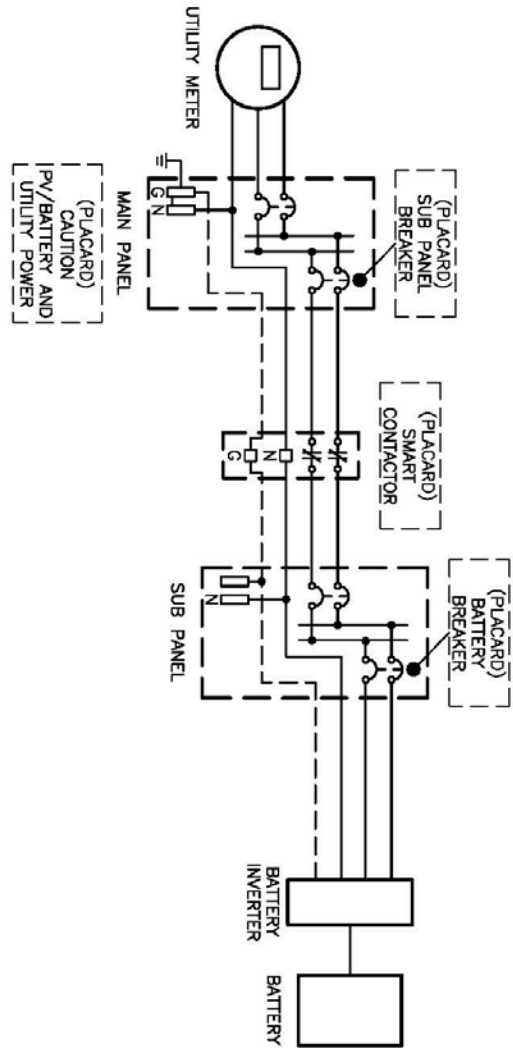

- NOTES:
1. FOR FULL HOME BACKUP, CONNECT ALL LOAD TO SUB-PANEL.
 2. SMART CONTRACTOR MUST OPEN DURING OUTAGE.
 3. THE BATTERY MUST NOT BACK FEED ONTO SYSTEM DURING OUTAGE.
 4. ALL WORK PERFORMED AND EQUIPMENT INSTALLED MUST COMPLY WITH NEC.
 5. BATTERY MUST NOT PROVIDE MORE POWER THAN CUSTOMER IS CONSUMING.

MID SOLAR PV PLACARDING REQUIREMENTS:

- MUST BE RED PLASTIC LAMINATE WITH MINIMUM 1/2" IMPRESSED WHITE LETTERING.
- MUST BE ADHERED WITH 5 MINUTE EPOXY.
- SEE THE SOLAR PLACARDING REQUIREMENTS SECTION OF THE SOLAR PHOTOVOLTAIC ELECTRIC SERVICE GUIDE FOR MORE INFORMATION.

MID PV EQUIPMENT SPACING REQUIREMENTS:

- MAINTAIN 6 INCH MINIMUM HORIZONTAL CLEARANCE WITH NO LARGE CONDUITS, DRAINS, MOLDING, OR ANY OBSTRUCTIONS OF ANY KIND BETWEEN BOXES.
- MAINTAIN A 3 INCH MINIMUM VERTICAL CLEARANCE WITH NO OBSTRUCTIONS.
- SEE THE DRAWINGS IN THE SOLAR PHOTOVOLTAIC ELECTRIC SERVICE GUIDE FOR MORE INFORMATION

| | | | | | |
|---|-----------------|------------------|---------------|--|--|
| MID T & D CONSTRUCTION STANDARDS | | | | DG INTERCONNECTION WITH BATTERY | |
| REVISION: | | | | OPTION FOUR | |
| DRAWN BY: JZ | APPROVED BY: MK | DATE: 02/08/2019 | DWG: PV-015.0 | | |

Drawing PV-015.0: DG Interconnection with Battery (Option Four)

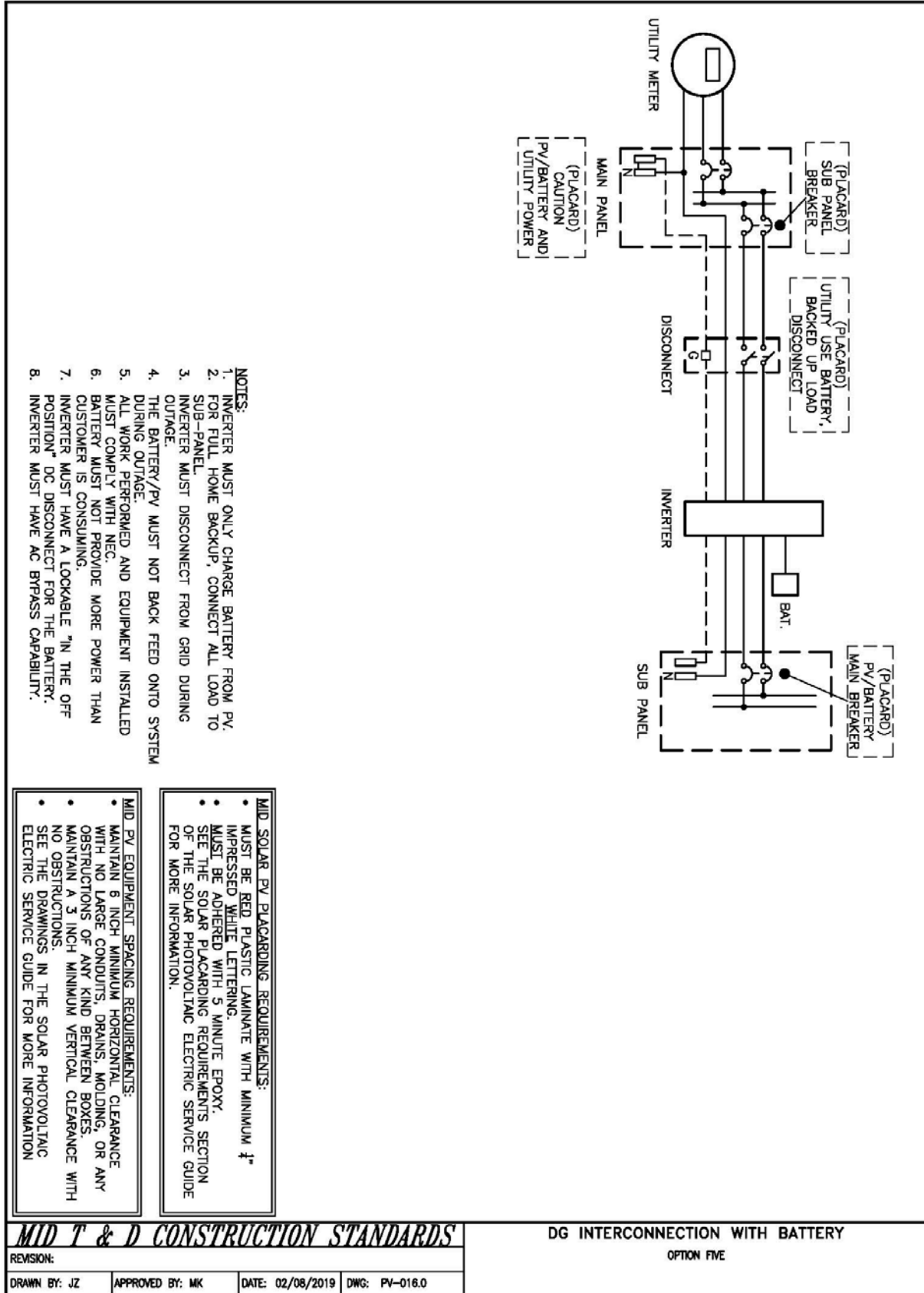

Drawing PV-016.0: DG Interconnection with Battery (Option Five)

Test Block Bypass TB Series

200 Amp/600 Volt, Self-Contained Socket Only



124TB

APPLICATION

- Single meter position
- Designed to receive watt-hour meters that meet ANSI C12.10
- Overhead/underground feed
- Surface mount

CONSTRUCTION

- Type 3R construction
- Safety socket with factory installed test/bypass facilities¹
- Snap type sealing ring included
- 5th jaw provision at nine o'clock - 124TB only
- Provisions for 2 AW base caps or hub kits on top
- Padlock provision
- Ring style

STANDARDS

- UL 414 listed, complies with ANSI C12.7

FINISH

- ANSI 61 gray acrylic electrocoat finish

ACCESSORIES

- Fifth jaw kit — catalog #60371
- Center and offset pole mounting brackets
- Bussed gutters, see page 76
- AW hubs
- Screw type sealing ring — catalog #25016D
- Steel or clear lexan covers for socket opening

Overhead or Underground—Surface Mount

| CABLE NUMBER | MAIN DISCONNECT | BENCH CIRCUITS | JIC RATING | JIC MAX. OWT | DENSITY | VOLTAGE | SERIAL TYPE | NUMBER OF WMS | HUB PROV. | CONDUCTOR LOG RANGE | | DIMENSIONS (INCHES) | | | |
|--------------|-----------------|----------------|------------|--------------|---------|---------|-------------|---------------|-----------|-------------------------|-------------------|---------------------|------------|-----------|-----------|
| | | | | | | | | | | PHASE CONDUCTOR LMB/LSD | NEUTRAL CONDUCTOR | FIGURE NUMBER | HEIGHT (H) | WIDTH (W) | DEPTH (D) |
| 124TB | NONE | NONE | + | .. | 200% | 600 | TF 3W | 4 | 3W | 6 AWG - 250 kcmil | 6 AWG - 10 AWG | Fig. 1 | 80 | 14 | 6 |
| 125TB | NONE | NONE | + | .. | 20% | 600 | 3F 3W | 5 | 3W | 6 AWG - 250 kcmil | 6 AWG - 10 AWG | Fig. 1 | 80 | 14 | 6 |
| 127TB | NONE | NONE | + | .. | 20% | 600 | 3F 4W | 7 | 3W | 6 AWG - 250 kcmil | 6 AWG - 10 AWG | Fig. 1 | 80 | 14 | 6 |

¹ = 60 J. in. torque recommended for circuit-closing nut

+ Meter sockets on this page have certain short-circuit current ratings when used in conformance with the tables on page 68

Note: For 208/120V, 75-31W systems, order 0 jaw unit and a 5th jaw kit

For Safety Socket Bypass instructions see page 74.

8-26

Switching Devices
Safety Switches



February 2007

Product Selection

600 Vac Heavy-Duty, Fusible, Single Throw

Specifications

- 30 – 1200 amperes.
- Horsepower rated.
- Suitable for service entrance use, except 1200 ampere on 480Y/277 or 600Y/347 grounded wye systems, per NEC 215-10 and 230-95, and 4-pole switches.
- UL listed File No. E5239.
- For factory modifications, refer to Pages 8-8 through 8-11.



DH362NRK

8

Table 8-44. Fusible 277/480 – 600 Volts

| System | Ampere Rating | Fuse Class Provision | Maximum Horsepower Ratings with Time Delay Fuses | | | | | | NEMA 1 Enclosure Indoor | | NEMA 3R Enclosure Rainproof | | |
|--|---------------|----------------------|--|----------|------------|----------|----------|----------|-------------------------|---------------|-----------------------------|---------------|---|
| | | | Single-Phase ac | | 3-Phase ac | | dc | | Catalog Number | Price U.S. \$ | Catalog Number | Price U.S. \$ | |
| | | | 480 Volt | 600 Volt | 480 Volt | 600 Volt | 250 Volt | 600 Volt | | | | | |
| 2-Pole — 480 Vac—600 Vac or dc (Suitable for Service Entrance Use with a Neutral Kit Installed) | | | | | | | | | | | | | |
| | 30 | H | 7-1/2 | 10 | — | — | — | 15 | — | DH261FGK | — | DH261FRK | — |
| | 60 | H | 20 | 25 | — | — | — | 25 | — | DH262FGK | — | DH262FRK | — |
| | 100 | H | 30 | 40 | — | — | — | 20 | — | DH263FGK | — | DH263FRK | — |
| | 200 | H | 50 | 50 | — | — | — | 50 | — | DH264FGK | — | DH264FRK | — |
| | 400 | H | — | — | — | — | — | — | — | DH265FGK | — | DH265FRK | — |
| | 600 | H | — | — | — | — | — | — | — | DH266FGK | — | DH266FRK | — |
| | 800 | L | — | — | — | — | — | — | — | DH267FGK | — | DH267FRK | — |
| 1200 | L | — | — | — | — | — | — | — | ④ | — | — | — | |
| 3-Pole — 480 Vac—600 Vac, 250 Vdc (Suitable for Service Entrance Use with a Neutral Kit Installed) | | | | | | | | | | | | | |
| | 30 | H | 7-1/2 | 10 | 15 | 20 | — | — | — | DH361FGK | — | DH361FRK | — |
| | 60 | H | 20 | 25 | 30 | 50 | — | — | — | DH362FGK | — | DH362FRK | — |
| | 100 | H | 30 | 40 | 60 | 75 | — | — | — | DH363FGK | — | DH363FRK | — |
| | 200 | H | 50 | 50 | 125 | 150 | — | — | — | DH364FGK | — | DH364FRK | — |
| | 400 | H | — | — | 250 | 350 | — | — | — | DH365FGK | — | DH365FRK | — |
| | 600 | H | — | — | 400 | 500 | — | — | — | DH366FGK | — | DH366FRK | — |
| | 800 | L | — | — | 500 | 500 | — | — | — | DH367FGK | — | DH367FRK | — |
| 1200 | L | — | — | 500 | 500 | — | — | — | DH368FGK | — | DH368FRK | — | |
| 4-Wire (Three Blades, 3-Fuses, S/N) 480 Vac—600 Vac, 250 Vdc | | | | | | | | | | | | | |
| | 30 | H | 7-1/2 | 10 | 15 | 20 | — | — | — | DH361NGK | — | DH361NRK | — |
| | 60 | H | 20 | 25 | 30 | 50 | — | — | — | DH362NGK | — | DH362NRK | — |
| | 100 | H | 30 | 40 | 60 | 75 | — | — | — | DH363NGK | — | DH363NRK | — |
| | 200 | H | 50 | 50 | 125 | 150 | — | — | — | DH364NGK | — | DH364NRK | — |
| | 400 | H | — | — | 250 | 350 | — | — | — | DH365NGK | — | DH365NRK | — |
| | 600 | H | — | — | 400 | 500 | — | — | — | DH366NGK | — | DH366NRK | — |
| | 800 | L | — | — | 500 | 500 | — | — | — | DH367NGK | — | DH367NRK | — |
| 1200 | L | — | — | 500 | 500 | — | — | — | DH368NGK | — | DH368NRK | — | |
| 4-Pole — 480 Vac—600 Vac, 250 Vdc | | | | | | | | | | | | | |
| | 30 | H | 20 | 25 | 15 | 20 | — | — | — | DH461FGK | — | ④ | — |
| | 60 | H | 40 | 50 | 30 | 50 | — | — | — | DH462FGK | — | ④ | — |
| | 100 | H | 50 | 50 | 60 | 75 | — | — | — | DH463FGK | — | ④ | — |
| | 200 | H | — | — | 125 | 150 | 40 | — | — | DH464FGK | — | ④ | — |
| | 400 | H | — | — | 250 | 350 | 50 | — | — | DH465FGK | — | ④④ | — |
| | 600 | H | — | — | 400 | 500 | — | — | — | DH466FGK | — | ④④ | — |
| | 800 | L | — | — | — | — | — | — | — | ④ | — | ④④ | — |

④ dc rating for 400 – 800 ampere switches is 250 volts.
 ④ Contact the Safety Switch Flex Center (1-888-329-9272) for availability of this product.
 ④ NEMA 12 enclosures (30 – 1200 amperes) can be field modified to meet NEMA 3R rainproof requirements when a factory provided drain hole is opened.
Note: 30 ampere heavy-duty switches with Type J fuse provisions are available from the factory only. See Table 8-15 on Page 8-10 for catalog numbers.

Discount Symbol 22CD

For more information visit www.eaton.com

CA08101001E

Single Meter Sockets - Without Bypass

Single Meter Sockets
Without Bypass

125 & 200 Amp



UG204 (closed)



UG204 (open)

Application

- Dedicated straight wire line section
- Receive ANSI C12.10 watt-hour meters
- Surface or flush mount (see chart)

Construction

- Ring type
- NEMA Type 3R
- ANSI 61 gray E-coat finish
- Aluminum snap ring included

Standards

- UL 414 Listed
- ANSI C12.7
- EUSERC 301A

Accessories

- 5th Jaw Kit - 50365
- AW Hub



| Part/UPC Number | Catalog Number | Amp Rating | Jaws | Service Type | Access | Line | Connections Load | Neutral |
|-----------------|-------------------|------------|------|--------------|--------|--------------|------------------|--------------|
| 78205142030 | U011 * | 125 | 4 | 1Ø/3W | UG | #14 - 2/0 | #14 - 2/0 | #14 - 2/0 |
| 78205156200 | UG204 | 200 | 4 | 1Ø/3W | UG | #6 - 350 MCM | #6 - 250 MCM | #6 - 250 MCM |
| 78205156205 | UG204 F | 200 | 4 | 1Ø/3W | UG | #6 - 350 MCM | #6 - 250 MCM | #6 - 250 MCM |
| 78205126000 | UG204 F SS | 200 | 4 | 1Ø/3W | UG | #6 - 350 MCM | #6 - 250 MCM | #6 - 250 MCM |
| 78205126005 | UG204 SS | 200 | 4 | 1Ø/3W | UG | #6 - 350 MCM | #6 - 250 MCM | #6 - 250 MCM |

| Part/UPC Number | Catalog Number | Overall Dimensions | | | Top Provision | Knockout Layout |
|-----------------|-------------------|--------------------|-------|---------------------------------|---------------|-----------------|
| | | Height | Width | Depth | | |
| 78205142030 | U011 * | 12" | 12" | 4 ⁵ / ₈ " | None | Fig. 1 |
| 78205156200 | UG204 | 17" | 14" | 4 ⁵ / ₈ " | None | Fig. 2 |
| 78205156205 | UG204 F | 17" | 14" | 6" | 2" max KO | Fig. 3 |
| 78205126000 | UG204 F SS | 17" | 14" | 6" | 2" max KO | Fig. 3 |
| 78205126005 | UG204 SS | 17" | 14" | 4 ⁵ / ₈ " | None | Fig. 2 |

*NOT compliant with EUSERC 301A

AIC Note:
For short circuit current ratings see page 131.

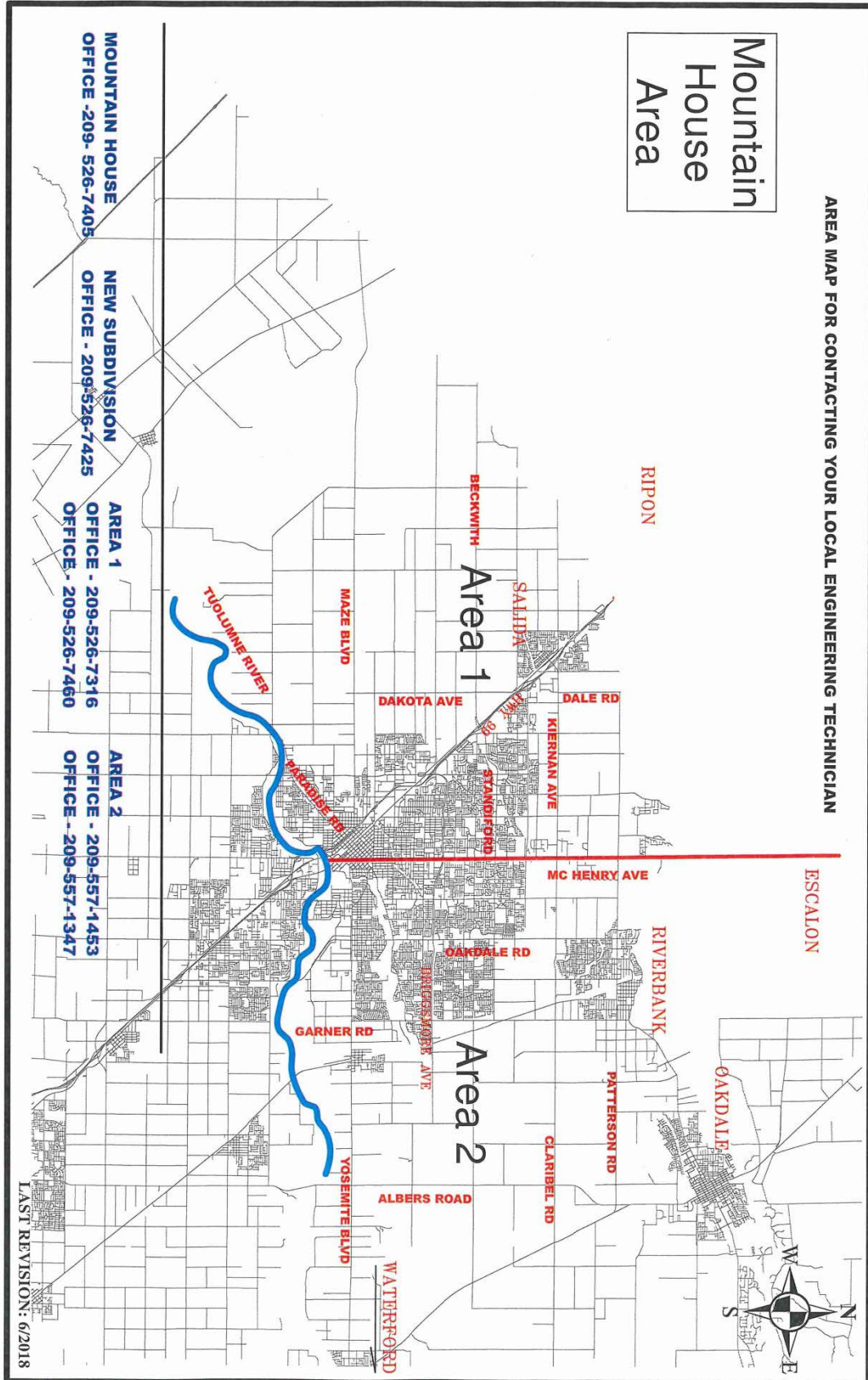

Form 1: Area Map

Service Guide Customer Input Form

The Modesto Irrigation District strives to provide excellent customer service. In an effort to improve our Service Guides, this form is provided so you can share your comments and suggestions. Please fill out this form and submit it with along with your comments. Please be as specific as possible. Once the form is complete, email the form to our Standards Department at electric_standards@mid.org, or mail the form to the Modesto Irrigation District office, attention Electrical Standards.

Modesto Irrigation District
 Attn: Electrical Standards
 PO Box 4060
 Modesto CA, 95352-4060

Name: _____ Date: _____

Phone Number: _____ Email: _____

Indicate which Service Guide your comments pertain to:

- | | |
|---|--|
| <input type="checkbox"/> Residential <input type="checkbox"/> Agricultural <input type="checkbox"/> Commercial and Industrial <input type="checkbox"/> Temporary | <input type="checkbox"/> Solar Photovoltaic <input type="checkbox"/> Electric Vehicle <input type="checkbox"/> Residential Subdivision <input type="checkbox"/> Street Lighting and Miscellaneous |
|---|--|

| | Not Effective | Somewhat Effective | Effective | Very Effective | N/A |
|--------------------------------|--------------------------|--------------------------|--------------------------|--------------------------|--------------------------|
| Organization of Service Guide | <input type="checkbox"/> | <input type="checkbox"/> | <input type="checkbox"/> | <input type="checkbox"/> | <input type="checkbox"/> |
| Requirements Were Clear | <input type="checkbox"/> | <input type="checkbox"/> | <input type="checkbox"/> | <input type="checkbox"/> | <input type="checkbox"/> |
| Effectiveness of Sample Forms | <input type="checkbox"/> | <input type="checkbox"/> | <input type="checkbox"/> | <input type="checkbox"/> | <input type="checkbox"/> |
| Effectiveness of Drawings | <input type="checkbox"/> | <input type="checkbox"/> | <input type="checkbox"/> | <input type="checkbox"/> | <input type="checkbox"/> |
| Effectiveness of Service Guide | <input type="checkbox"/> | <input type="checkbox"/> | <input type="checkbox"/> | <input type="checkbox"/> | <input type="checkbox"/> |

Comments: _____

