

# MODESTO IRRIGATION DISTRICT



# IRRIGATION STANDARD CONSTRUCTION DETAILS

April 2022



# TABLE OF CONTENTS

<u>Drawing No.</u>	<u>Description</u>
<b>G</b>	<b>GENERAL INFORMATION</b>
G 01 .....	Abbreviations
G 02 .....	General Notes
G 03 .....	Easements and Encroachments
G 04 .....	Concrete Notes
G 05 .....	Steel Reinforcement
G 06 .....	Opening Reinforcement
G 07 .....	New Construction Joint
G 08 .....	Concrete Lined Canal Details & Notes
G 09 .....	Trench Backfill
G 10 .....	Concrete Pipe Thrust Block
G 11 .....	M.I.D. Mortar Mix Notes
G 12 .....	Connection To Existing Structure
G 13 .....	Standard Canal Gate Notes
<b>C</b>	<b>CONCRETE PIPELINE DETAILS</b>
C 01.....	Concrete Collar for Concrete Pipeline
C 05.....	Concrete Pipeline Connection to Existing Structure
C 10.....	Control Box for Concrete Pipeline
C 11.....	Precast Control Box for Concrete Pipeline
C 15.....	Pressure Box for Concrete Pipeline
C 20.....	Pressure Manhole for Concrete Pipeline
C 25.....	Pressure Box With 20" Vent for Concrete Pipeline
C 30.....	Overpour Box for Concrete Pipeline
C 35.....	Standard Canal Gate for Concrete Pipeline
C 36.....	Standard Canal Gate for Concrete Pipeline With Sump
C 37.....	Dirt Ditch Standard Canal Gate for Concrete Pipeline
C 40.....	Concrete Air Vent for Concrete Pipeline
C 45.....	Concrete Air Vent Cover for Concrete Pipeline
C 50.....	Steel Air Vent for Concrete Pipeline
C 55.....	Concrete Plug for Concrete Pipeline
C 60.....	Inlet/Outlet Box Structure for Concrete Pipeline
C 75.....	Long Control Box for Concrete Pipeline
C 99.....	Access Hole for Concrete Pipeline

**Drawing No.**            **Description**

**CL**                    **CANAL DETAILS**

- CL 10.....Typical Canal Cross Section
- CL 15.....Canal Step Detail

**CR**                    **CROSSING DETAILS**

- CR 01.....Boring General Notes
- CR 02.....Jack & Bore Pipeline Crossing Under M.I.D. Canal
- CR 03.....Jack & Bore Pipeline Crossing Under M.I.D. Pipeline
- CR 04.....Directional Boring Pipeline Crossing Under M.I.D. Canal
- CR 05.....Directional Boring Pipeline Crossing Under M.I.D. Pipeline
- CR 10.....Pipeline Crossing Over M.I.D. Pipeline Using Open-Cut Trench
- CR 11.....Pipeline Crossing Under M.I.D. Pipeline Using Open-Cut Trench
- CR 15.....Headwall Setbacks On Road Crossing
- CR 20.....Utility Crossing Marker

**M**                    **MISCELLANEOUS DETAILS**

- M 05.....Driveway Slab for Pipeline
- M 10.....Standard Redwood Deck Detail
- M 15.....Typical M.I.D. Canal Roadway Gate Detail
- M 20.....Barbed Wire Fence Detail
- M 25.....Typical Discharge Line Details
- M 45.....Structure Handrailing
- M 46.....Structure Ladder
- M 47.....Structure Grating
- M 50.....Inlet Grate
- M 55.....Private Irrigation Backflush Filter Discharge
- M 56.....Private Irrigation Backflush Filter Discharge into Standpipe
- M 57.....Private Irrigation Backflush Filter Discharge into Control Box
- M 60.....Standard Canal Gate With New Sump In Existing Headwall

**P**                    **P.V.C. PIPELINE DETAILS**

- P 01.....Starter Coupler for P.V.C. Pipeline
- P 05.....P.V.C. Connection to Existing Structure
- P 10.....Control Box for P.V.C. Pipeline
- P 15.....Precast Control Box for P.V.C. Pipeline
- P 20.....Pressure Box for P.V.C. Pipeline
- P 25.....Pressure Manhole Box for P.V.C. Pipeline

**Drawing No.**            **Description**

- P 30.....Overpour Box for P.V.C. Pipeline
- P 45..... Standard Canal Gate for P.V.C. Pipeline
- P 46..... Standard Canal Gate for P.V.C. Pipeline With Sump
- P 47.....Dirt Ditch Standard Canal Gate for P.V.C. Pipeline
- P 50.....Air Vent for P.V.C. Pipeline
- P 55..... Inlet/Outlet Box Structure for P.V.C. Pipeline

**V**                    **VALVE DETAILS**

- V 01.....Field Valve Structures for Concrete Pipeline
- V 20..... Field Valve Structures for P.V.C. Pipeline
- V 40.....Line Gate Structure for P.V.C. Pipeline
- V 41.....Line Gate Structure for Concrete Pipeline
- V 45.....Offset – Arch / Alfalfa Valve Structure



REV	CHANGE	DATE	BY
1	RELEASE	06/17	LH
2			
3			
4			

AB	AGGREGATE BASE	HD	HEAD		
AC	ASPHALT CONCRETE	HDPE	HIGH DENSITY POLYETHYLENE		
ACI	AMERICAN CONCRETE INSTITUTE				
ADD'L	ADDITIONAL	HGL	HYDRAULIC GRADE LINE		
AGG.	AGGREGATE	HORIZ.	HORIZONTAL		
AISC	AMERICAN INSTITUTE OF STEEL CONSTRUCTION	HP	HINGE POINT		
ALIGN.	ALIGNMENT	HWL	HIGH WATER LEVEL	RGS	RIGID GALVANIZED STEEL
AP	ANGLE POINT	IBC	INTERNATIONAL BUILDING CODE	ROW	RIGHT OF WAY
APPROX.	APPROXIMATE	ID	INSIDE DIAMETER	RP	RADIUS POINT
ASTM	AMERICAN SOCIETY FOR TESTING AND MATERIALS	IN	INCH	RR	RAILROAD
AV	AIR VENT	INV.	INVERT	RT	RIGHT
BC	BEGIN CURVE	IRR.	IRRIGATION	RTU	REMOTE TERMINAL UNIT
BLDG	BUILDING	LB/LBS	POUND/POUNDS	S	SLOPE
BM	BENCHMARK	LC	LENGTH OF CURVE	SCH.	SCHEDULE
BTM	BOTTOM	LCW	LONG CRESTED WEIR	SEC	SECTION
C	CHANNEL	LF	LINEAR FEET	SF	SQUARE FEET/FOOT
CA	CALIFORNIA	LT	LEFT	SP	SERVICE POLE
CAL-OSHA	CALIFORNIA DIVISION OF OCCUPATIONAL SAFETY AND HEALTH ADMINISTRATION	MAX.	MAXIMUM	SQ	SQUARE
CFS	CUBIC FEET PER SECOND	MH	MANHOLE	SS	STAINLESS STEEL
CIP	CAST IRON PIPE	M.I.D.	MODESTO IRRIGATION DISTRICT	ST	STRUCTURAL TUBING
C.I.P.C.P.	CAST-IN-PLACE CONCRETE PIPE	MIL	THOUSANDTHS OF AN INCH	STA	STATION
C.I.P.P.	CURED-IN-PLACE PIPE	MIN.	MINIMUM	STD	STANDARD
CL	CLASS	MIPT	MALE IRON PIPE THREAD	SWL	SWALE
€	CENTERLINE	MISC.	MISCELLANEOUS	STWL	STILLING WELL
CLR.	CLEAR, CLEARANCE	NAVD	NORTH AMERICAN VERTICAL DATUM	SYM	SYMMETRICAL
CMLC	CEMENT MORTAR LINED & COATED	NGVD	NATIONAL GEODETIC VERTICAL DATUM	T&B	TOP AND BOTTOM
COMP	CORRUGATED METAL PIPE	NIC	NOT IN CONTRACT	TBM	TEMPORARY BENCHMARK
CONC.	CONCRETE	NO./###	NUMBER	TC	TOP OF CURB
CONT.	CONTINUOUS	NRCS	NATURAL RESOURCES CONSERVATION SERVICE	TCE	TEMPORARY CONSTRUCTION EASEMENT
CONST.	CONSTRUCT/CONSTRUCTION	NTS	NOT TO SCALE	TELE	TELEPHONE
CP	CONTROL POINT	O.C.	ON CENTER	TL	TOP OF LINING
CY	CUBIC YARDS	OD	OUTSIDE DIAMETER	TOB	TOP OF BANK
Db	BAR DIAMETER	OH	OVERHEAD	TOE	TOE OF SLOPE
DEG	DEGREE	OP	OPERATING	TOP	TOP OF SLOPE
DEMO	DEMOLISH/DEMOLITION	OSHA	OCCUPATIONAL SAFETY AND HEALTH ADMINISTRATION	TP	TELEPHONE POLE
DIA, Ø	DIAMETER	O&M	OPERATIONS AND MAINTENANCE	TR	TELEPHONE RISER
DIM.	DIMENSION	(P)	PROPOSED	TRANS	TRANSFORMER
DIP	DUCTILE IRON PIPE	PC	POINT OF CURVATURE	TS	TOP OF STRUCTURE
D/S	DOWNSTREAM	PCC	POINT OF COMPOUND CURVATURE	TYP.	TYPICAL
DWG	DRAWING	PI	POINT OF INTERSECTION	TWL	TOP OF WALL
EX.	EXISTING	PIP	PLASTIC IRRIGATION PIPE	UG	UNDERGROUND
EA.	EACH	PLC	PROGRAMMABLE LOGIC CONTROLLER	UP	UTILITY POLE
EC	END CURVE	PL	PROPERTY LINE/PLATE	U/S	UPSTREAM
EF	EACH FACE	POC	POINT ON CURVE	VERT	VERTICAL
EG	EXISTING GRADE	POL	POINT ON LINE	WL	WATER LEVEL
EL, ELEV.	ELEVATION	POT	POINT ON TANGENT	W/	WITH
ELEC	ELECTRIC	PP	POWER POLE	W/O	WITHOUT
ELL, ELB	ELBOW	PRC	POINT OF REVERSE CURVATURE	YD	YARD
EP	EDGE OF PAVEMENT	PSF	POUNDS PER SQUARE FOOT	@	AT
ESMT	EASEMENT	PSI	POUNDS PER SQUARE INCH	<	LESS THAN
EW	EACH WAY	PT	POINT OF TANGENCY	>	GREATER THAN
F&I	FURNISH & INSTALL	PUE	PUBLIC UTILITY EASEMENT	∠	ANGLE
FB	FLAT BAR	P.V.C.	POLYVINYL CHLORIDE		
FF	FINISHED FLOOR	PVMT	PAVEMENT		
FG	FINISHED GRADE	RAD, R	RADIUS		
FIPT	FEMALE IRON PIPE THREAD	RC	RADIUS OF CURVE		
FL	FLOW LINE	R.C.P.	REINFORCED CONCRETE PIPE		
FT	FEET/FOOT	REF	REFERENCE		
GA	GAUGE	REQ'D	REQUIRED		
GALV.	GALVANIZED	REV	REVISION		
GB	GRADE BREAK	R.G.R.C.P.	RUBBER GASKETED REINFORCED CONCRETE PIPE		
GPM	GALLONS PER MINUTE				
GUY	GUY WIRE				



### ABBREVIATIONS

DATE: JUNE 2017

STANDARD #:

G 01

SCALE: NONE

APPROVED BY:

CHAD J. TIENKEN, P.E., P.L.S.  
CIVIL ENGINEERING MANAGER

DATE: 9/7/17

REV	CHANGE	DATE	BY
△	RELEASE	06/17	LH
△	REVISED	04/22	LH
△			
△			

**GENERAL NOTES:**

1. THE SIGNATURE OF THE MODESTO IRRIGATION DISTRICT (M.I.D.) ON DRAWINGS CONSTITUTES M.I.D.'S APPROVAL OF THE SAME AS TO THE ENGINEERING ASPECTS THEREOF ONLY AND DOES NOT AUTHORIZE, EXPRESSLY OR IMPLICITLY THE CONSTRUCTION OF ANY ASPECT HEREOF OR THE INTERFERENCE WITH ANY PROPERTY, EQUIPMENT, OR INTEREST OF THE M.I.D. NO SUCH CONSTRUCTION OR INTERFERENCE SHALL OCCUR UNTIL M.I.D. HAS OBTAINED, BY SEPARATE AGREEMENT SUCH AGREEMENTS AS M.I.D. DEEMS NECESSARY FOR THE PROTECTION OF ITS FACILITIES.
2. ALL CONSTRUCTION WITHIN THE M.I.D. RIGHT OF WAY SHALL BE DONE IN ACCORDANCE WITH THE APPROVED DRAWINGS AND THE CURRENT EDITION OF M.I.D. STANDARDS AND/OR STANDARD SPECIFICATIONS OF OTHER GOVERNING AGENCIES, AS APPLICABLE.
3. CONSTRUCTION WITHIN THE M.I.D. RIGHT OF WAY WILL NOT BE ALLOWED DURING THE IRRIGATION SEASON UNLESS APPROVED BY M.I.D. (IRRIGATION SEASON TYPICALLY MARCH 1 TO OCTOBER 31).
4. CONTRACTOR SHALL PROVIDE AN ALTERNATE STORM WATER BYPASS DURING CONSTRUCTION UNLESS DIRECTED OTHERWISE BY M.I.D. ENGINEER. BYPASS PLAN SHALL BE SUBMITTED FOR M.I.D. ENGINEER APPROVAL PRIOR TO BEGINNING CONSTRUCTION.
5. WHERE THE PLANS OR SPECIFICATIONS DESCRIBE PORTIONS OF THE WORK IN GENERAL TERMS, BUT NOT IN COMPLETE DETAIL, IT IS UNDERSTOOD THAT ONLY THE BEST GENERAL PRACTICE IS TO PREVAIL AND THAT ONLY MATERIALS AND WORKMANSHIP OF THE FIRST QUALITY ARE TO BE USED.
6. M.I.D. STANDARD DETAILS MAY REQUIRE MODIFICATIONS BASED ON SITE SPECIFIC FIELD CONDITIONS. SUCH MODIFICATIONS SHALL BE REVIEWED AND PRE-APPROVED IN WRITING BY M.I.D. ENGINEER PRIOR TO CONSTRUCTION.
7. CONTRACTOR AGREES TO ASSUME SOLE AND COMPLETE RESPONSIBILITY FOR THE JOB SITE CONDITIONS DURING THE COURSE OF CONSTRUCTION OF THE PROJECT, INCLUDING SAFETY OF ALL PERSONS AND PROPERTY. THIS REQUIREMENT SHALL APPLY CONTINUOUSLY AND NOT BE LIMITED TO NORMAL WORKING HOURS.
8. CAL-OSHA SAFETY REQUIREMENTS SHALL BE IN EFFECT DURING ALL CONSTRUCTION. SPECIAL SAFETY PRECAUTIONS SHALL BE TAKEN WHEN WORKING IN THE VICINITY OF GAS, OIL, OR ELECTRICAL LINES.
9. IT IS THE RESPONSIBILITY OF THE CONTRACTOR TO COMPLY WITH CALIFORNIA GOVERNMENT CODE 4216, AS APPLICABLE. TO OBTAIN A DIG ALERT IDENTIFICATION NUMBER, CALL 811 AT LEAST 2 WORKING DAYS BEFORE DIGGING UNDERGROUND.
10. M.I.D. WILL NOT BE RESPONSIBLE FOR, OR LIABLE FOR, UNAUTHORIZED CHANGES TO OR USES OF APPROVED PLANS. ALL CHANGES TO THE PLANS MUST BE OBTAINED IN WRITING FROM M.I.D. ENGINEER, AND MUST BE APPROVED BY THE PREPARER OF THE PLANS.
11. CONTRACTOR SHALL BE REQUIRED TO HAVE A PRE-CONSTRUCTION CONFERENCE WITH M.I.D. ENGINEER, PRIOR TO STARTING ANY WORK WITHIN THE M.I.D. RIGHT OF WAY.
12. BACKFILL AND SUBGRADES SHALL BE COMPACTED TO MINIMUM 90% RELATIVE DENSITY PER ASTM D-1557 WITHIN THE M.I.D. RIGHT OF WAY, UNLESS DIRECTED OTHERWISE BY M.I.D. ENGINEER. SEE M.I.D. STANDARD G 09 - TRENCH BACKFILL\* FOR ADDITIONAL BACKFILL REQUIREMENTS.
13. A SET OF APPROVED PLANS SHALL BE ON THE JOB SITE AT ALL TIMES DURING CONSTRUCTION.
14. THE CONTRACTOR SHALL EXERCISE DUE CAUTION IN PROTECTING EXISTING FACILITIES. THE CONTRACTOR SHALL GIVE PARTICULAR CARE TO PROTECTING EXISTING PIPELINES DURING CONSTRUCTION. THE CONTRACTOR SHALL CAREFULLY PRESERVE BENCHMARKS, REFERENCE POINTS AND STAKES, AND SHALL BEAR ALL EXPENSES FOR REPLACEMENT AND/OR ERRORS CAUSED BY THEIR UNNECESSARY LOSS OR DISTURBANCE. ANY DAMAGES TO M.I.D. FACILITIES DURING CONSTRUCTION SHALL BE REPAIRED OR REPLACED IN A MANNER APPROVED BY M.I.D. ENGINEER AT THE SOLE COST OF THE CONTRACTOR.
15. TRACER WIRE SHALL BE REQUIRED IN ALL AREAS WHERE PIPELINE IS REPLACED, RELOCATED, UPGRADED OR INSTALLED UNLESS OTHERWISE PRE-APPROVED BY M.I.D. ENGINEER. THE TRACER WIRE SHALL BE PURPLE THWN (THERMOPLASTIC HEAT AND WATER RESISTANT NYLON) INSULATED SOLID COPPER, SOFT DRAWN WIRE NO. 10 AMERICAN WIRE GAUGE, ATTACHED TO THE TOP OF ALL PIPES WITH TAPE, AND CONTINUOUS ALONG PIPE. ALL ENDS SHALL BE ENCLOSED WITHIN A VALVE BOX, CENTERED ON THE PIPELINE.

\*REFERENCED STANDARD(S): G 09



GENERAL NOTES	
DATE: JUNE 2017	STANDARD #: G 02
SCALE: NONE	SHEET 1 OF 2

APPROVED BY:  
  
 DAVID B. BAKKER, P.E.  
 SENIOR CIVIL ENGINEER  
 DATE: 4/29/22



REV	CHANGE	DATE	BY
△	RELEASE	06/17	LH
△	REVISED	04/22	LH
△			
△			

GENERAL NOTES (CONT.):

16. ANY WORK WITHIN THE M.I.D. RIGHT OF WAY SHALL NOT BE DEEMED COMPLETE UNTIL THE M.I.D. ENGINEERING DEPARTMENT HAS BEEN PROVIDED WITH A SET OF RECORD DRAWINGS IN HARD COPY AND PDF OR AS DIRCTED BY M.I.D. ENGINEER.
17. CONTACT THE M.I.D. ENGINEERING DEPARTMENT AT LEAST TWO (2) WORKING DAYS PRIOR TO ANY CONSTRUCTION AND/OR NECESSARY INSPECTIONS. WORK WITHIN THE M.I.D. RIGHT OF WAY SHALL PROCEED IN A CONTINUOUS MANNER ONCE STARTED. M.I.D. ENGINEER SHALL BE NOTIFIED OF ANY WORK STOPPAGES. WHENEVER WORK IS TO RESTART, M.I.D. ENGINEER SHALL REQUIRE AN ADDITIONAL TWO (2) WORKING DAYS NOTICE. M.I.D. ENGINEER SHALL ALSO BE CONTACTED A MINIMUM OF TWO (2) WORKING DAYS PRIOR TO ALL CONSTRUCTION SCHEDULED ON A HOLIDAY OR WEEKEND. PHONE: 209-526-7563.
18. UNLESS OTHERWISE STATED, ALL STATIONS INDICATED ON THE PLANS ARE IN REFERENCE TO THE CENTERLINE OF THE PROPOSED STRUCTURE.
19. M.I.D. ENGINEER SHALL AT ALL TIMES HAVE ACCESS TO THE WORK WHEREVER IT IS IN PREPARATION AND PROGRESS.
20. IT IS INTENDED THAT THESE PLANS AND SPECIFICATIONS REQUIRE ALL LABOR AND MATERIALS NECESSARY AND PROPER FOR THE WORK CONTEMPLATED AND THAT THE WORK BE COMPLETED IN ACCORDANCE WITH THEIR TRUE INTENT AND PURPOSE. THE CONTRACTOR SHALL NOTIFY M.I.D. ENGINEER IMMEDIATELY REGARDING ANY DISCREPANCIES OR AMBIGUITIES, WHICH MAY EXIST IN THE PLANS OR SPECIFICATIONS. M.I.D. ENGINEER'S INTERPRETATION OR CORRECTION THEREOF SHALL BE CONCLUSIVE. M.I.D. ENGINEER WILL HAVE AUTHORITY TO REJECT WORK WHICH DOES NOT CONFORM TO THE PLANS AND SPECIFICATIONS.
21. THE CONTRACTOR SHALL NOT LEAVE "IN USE" M.I.D. PIPELINE PROJECTS INCOMPLETE FOR MORE THAN TWO (2) WEEKS. WHEN CONDITIONS REQUIRE, AND DETERMINED SOLELY BY M.I.D. ENGINEER, CONTRACTOR SHALL PROVIDE A TEMPORARY DIVERSION SYSTEM TO PROVIDE FOR IRRIGATION WATER DELIVERY OR STORM WATER REMOVAL.
22. ASTM C-361 RUBBER GASKETED REINFORCED CONCRETE PIPE (R.G.R.C.P.) WITH APPROPRIATE WALL THICKNESS FOR THE PRESSURE AND TRAFFIC LOADS IS REQUIRED FOR M.I.D. CONCRETE PIPELINES. CONTRACTOR SHALL SUBMIT FACTORY TEST DATA TO M.I.D. ENGINEER, VERIFYING THAT PIPE JOINTS CONFORM TO NO LEAKAGE AT HYDROSTATIC PRESSURES UP TO TWENTY-FIVE (25) FEET. FIELD TESTS, IF REQUIRED, SHALL BE PERFORMED IN THE PRESENCE OF M.I.D. ENGINEER.
23. POLYVINYL CHLORIDE (P.V.C.) PIPE SHALL BE A MINIMUM OF 100 PSI PIP WITHIN LIMITS OF M.I.D. RIGHT OF WAY, OR AS DIRECTED BY THESE STANDARDS OR M.I.D. ENGINEER.
24. 30 INCHES MINIMUM COVER SHALL BE PROVIDED OVER ALL PIPELINES UNLESS DIRECTED BY M.I.D. ENGINEER.
25. DIMENSIONS, ELEVATIONS, PIPE SIZES, AND STRUCTURE LOCATIONS SHALL BE DETERMINED BY M.I.D.
26. ALL DIMENSIONS ARE TO BE FIELD VERIFIED BY CONTRACTOR PRIOR TO COMMENCING WORK OR FABRICATION. IF ANY CONDITION EXISTS NOT AS SHOWN ON THE DRAWINGS, M.I.D. ENGINEER SHALL BE NOTIFIED IMMEDIATELY.
27. DO NOT SCALE DRAWINGS. WRITTEN DIMENSIONS SHALL HAVE PRECEDENCE OVER SCALED DRAWINGS. CONTRACTOR SHALL VERIFY DIMENSIONS AND MEASUREMENTS AT SITE.
28. ALL WORK SHALL BE PERFORMED USING MATERIALS AND METHODS IN ACCORDANCE WITH APPLICABLE SECTIONS OF THE CURRENT INTERNATIONAL BUILDING CODE (IBC), CALIFORNIA BUILDING CODE (CBC), ACI 318, LOCAL CODES AND ORDINANCES. REPORT ALL DISCREPANCIES TO M.I.D. ENGINEER IMMEDIATELY.
29. ANY CHANGES TO THE APPROVED SET OF PLANS WITHOUT NOTIFYING M.I.D. ENGINEER PRIOR TO SUCH CHANGES ABSOLVES SAID ENGINEER FROM ANY AND ALL RESPONSIBILITY WITH RESPECT TO THE LIABILITY, DAMAGE OR EXTRA WORK RESULTING FROM SAID CHANGES.
30. BUILDING PERMITS, IF REQUIRED, MUST BE OBTAINED BEFORE STARTING CONSTRUCTION.



GENERAL NOTES  
(CONT.)

DATE: JUNE 2017

STANDARD #: G 02  
SHEET 2 OF 2

SCALE: NONE

APPROVED BY:

*David B. Bakker*

DAVID B. BAKKER, P.E.  
SENIOR CIVIL ENGINEER

DATE: 4/29/22

REV	CHANGE	DATE	BY
1	RELEASE	06/17	LH
2	REVISED	04/22	LH
3			
4			

1. AGREEMENTS ARE REQUIRED FOR ANY EXISTING ENCROACHMENTS OR PROPOSED IMPROVEMENTS WITHIN THE CURRENT OR REQUESTED M.I.D. EASEMENT.
2. M.I.D. MAY REQUIRE THAT ITS EASEMENTS, RIGHTS OF WAY, AND FEE TITLE PROPERTY BE FENCED TO M.I.D. STANDARDS. THE NEED FOR FENCING WILL BE EVALUATED ON A CASE BY CASE BASIS. THE COST OF FENCING SHALL BE BORNE BY THE DEVELOPER/LANDOWNER.
3. ACCESS GATES AND FENCING WHICH CROSS THE M.I.D. RIGHT OF WAY THAT DO NOT IMPACT M.I.D. OPERATIONS AND MAINTENANCE AND ARE NOT BURDENSOME ON M.I.D. MAY BE PERMITTED UNDER AN ENCROACHMENT AGREEMENT UPON APPROVAL BY M.I.D. ENGINEER.
4. EXISTING M.I.D. FACILITIES WITHIN A PUBLIC ROAD RIGHT OF WAY SHALL BE RELOCATED INTO A RIGHT OF WAY EASEMENT DEDICATED SOLELY TO M.I.D. AT THE COST OF THE DEVELOPER.
5. STANDARD EASEMENT WIDTHS FOR M.I.D. FACILITIES SHALL BE THE FOLLOWING UNLESS DIRECTED BY M.I.D. ENGINEER:

MAIN CANALS	VARIES	CENTERED ON CANAL
DRAINS	60 FT	CENTERED ON CANAL/DRAIN
PIPELINES	30 FT	CENTERED ON PIPELINE
PIPELINES ADJACENT TO ROADWAYS	20 FT	
PIPELINES ADJACENT TO PUE	15 FT	
PUMP SITES	40 FT	SQUARE CENTERED ON PUMP
6. STANDARD ROADWAY WIDTHS SHALL BE 16' MINIMUM.
7. EASEMENT WIDTHS FOR JOINT PROJECTS SHALL MEET THE ABOVE MINIMUM EASEMENT WIDTHS PLUS ANY ADDITIONAL EASEMENT WIDTH THAT MAY BE REQUIRED BASED ON THE SPECIFIC PROJECT USES OR AS APPROVED BY THE BOARD OF DIRECTORS.
8. IF AN EXISTING M.I.D. FACILITY IS NOT CENTERED ON THE PROPERTY BOUNDARY BETWEEN TWO (2) PROPERTIES, M.I.D. MAY REQUIRE AN EASEMENT WIDTH BASED ON THE DISTANCE TO THE CENTERLINE OF THE M.I.D. FACILITY.



EASEMENTS AND ENCROACHMENTS

DATE: JUNE 2017

STANDARD #:

G 03

SCALE: NONE

APPROVED BY:

*David B. Bakker*

DAVID B. BAKKER, P.E.  
SENIOR CIVIL ENGINEER

DATE: 4/29/22

**CAST-IN-PLACE CONCRETE NOTES**

REV	CHANGE	DATE	BY
1	RELEASE	06/17	LH
2			
3			
4			

1. UNLESS DIRECTED OTHERWISE BY M.I.D. ENGINEER, MINIMUM CONCRETE 28 DAY COMPRESSIVE STRENGTH SHALL BE 3,000 PSI. CEMENT SHALL BE ASTM TYPE II PORTLAND CEMENT AND BE FREE OF LUMPS AND PARTIALLY SET MASSES, AND PROPORTIONED TO INCLUDE NOT LESS THAN 6 SACKS OF CEMENT PER CUBIC YARD OF CONCRETE AND HAVE A MAXIMUM WATER-CEMENT RATIO OF 0.50. WATER SHALL BE FREE FROM ACID, ALKALI, OILS OR ORGANIC MATTER. AGGREGATE SHALL BE CLEAN, HARD, STRONG AND DURABLE, AND FREE FROM DIRT AND OTHER SUBSTANCES DELETERIOUS TO CONCRETE. THE FINE AND COARSE AGGREGATES SHALL BE A WELL GRADED MIX APPROVED BY M.I.D. ENGINEER. THE MAXIMUM SIZE OF AGGREGATE SHALL NOT EXCEED 3/4 INCH AND SHALL CONFORM TO THE REQUIREMENTS OF ASTM C-33.
2. CONSISTENCY OF THE CONCRETE SHALL ALLOW IT TO BE WORKED INTO PLACE WITHOUT SEGREGATION. SLUMP SHALL BE 4 INCHES MAXIMUM. FORMS SHALL BE BRACED AND/OR TIED TOGETHER SO AS TO MAINTAIN POSITION AND SHAPE AND BE SUFFICIENTLY TIGHT TO PREVENT LEAKAGE OF CONCRETE.
3. ALL VERTICAL CONCRETE SURFACES SHALL BE POURED AGAINST FORMS IN ALL CASES. CONCRETE SHALL NOT BE DROPPED MORE THAN 5 FEET VERTICALLY UNLESS SUITABLE EQUIPMENT IS USED TO PREVENT SEGREGATION AND SHALL BE VIBRATED IN 18 INCH, HORIZONTAL LIFTS. CONCRETE SHALL NOT BE MOVED DISTANCES OVER 5 FEET HORIZONTALLY USING A VIBRATOR. CONSOLIDATION OF CONCRETE SHALL BE ACCOMPLISHED BY MEANS OF INTERNAL TYPE MECHANICAL VIBRATORS, OR AS PRE-APPROVED BY M.I.D. ENGINEER.
4. ALL CAST-IN-PLACE CONCRETE STRUCTURES SHALL BE FORMED INSIDE AND OUT AND CONCRETE VIBRATED SUFFICIENTLY TO PROVIDE FOR SMOOTH SURFACED WALLS/FLOORS WITHOUT VOIDS AND HONEYCOMBS.
5. REINFORCING STEEL SHALL BE IN ACCORDANCE WITH STRUCTURAL DETAILS AND NOTES. SEE M.I.D. STANDARD G 05 - STEEL REINFORCEMENT\*.
6. GUIDELINES FOR CONCRETING IN HOT AND COLD WEATHER AS SET FORTH IN NRCS CONSTRUCTION SPECIFICATION 901 SHALL BE FOLLOWED.
7. ALL SLABS SHALL BE SLOPED TO ALLOW DRAINAGE OF RUNOFF WATER TO PREVENT PONDING.
8. CONCRETE SHALL BE PREVENTED FROM PREMATURE DRYING FOR A CURING PERIOD OF AT LEAST SEVEN DAYS AFTER IT IS PLACED. EXPOSED SURFACES SHALL BE KEPT CONTINUOUSLY MOIST FOR THE ENTIRE PERIOD. IN LIEU OF WATER CURING, THE CONCRETE SHALL BE PROTECTED BY SPRAYING WITH A CURING COMPOUND PRE-APPROVED BY M.I.D. ENGINEER. ALL SURFACES SHALL BE KEPT MOIST UNTIL THE COMPOUND IS APPLIED.
9. CONSTRUCTION JOINTS SHALL BE PLACED AS SHOWN ON THE PLANS OR AS PRE-APPROVED BY M.I.D. ENGINEER ONLY. ENTIRE SURFACE UNDER WALL TO BE ROUGHENED WHILE WET, TO 1/8 INCH MINIMUM AMPLITUDE/DEPTH. JOINTS SHALL BE THOROUGHLY CLEANED AND ALL LAITANCE REMOVED BEFORE EACH NEW POUR IS MADE. EACH JOINT SHALL BE WETTED IMMEDIATELY BEFORE THE PLACEMENT OF NEW CONCRETE. SEE M.I.D. STANDARDS G 07 - NEW CONSTRUCTION JOINT\* AND G 12 - CONNECTION TO EXISTING STRUCTURE\*.
10. 1 INCH OR 3/4 INCH CHAMFER SHALL BE PROVIDED ON ALL EXPOSED EDGES OF CONCRETE STRUCTURES.
11. ALL STRUCTURE SUBGRADES, FORMS, AND STEEL REINFORCEMENT SHALL BE INSPECTED AND APPROVED BY M.I.D. ENGINEER PRIOR TO CONCRETE PLACEMENT OR BACKFILL. BACKFILL SHALL NOT OCCUR UNTIL 7 DAYS AFTER CONCRETE PLACEMENT.

\*REFERENCED STANDARD(S): G 05, G 07, G 12



**CONCRETE NOTES**

DATE: JUNE 2017

STANDARD #:

G 04

SCALE: NONE

APPROVED BY:

CHAD J. TIENKEN, P.E., P.L.S.  
CIVIL ENGINEERING MANAGER

DATE: 9/7/17

REV	CHANGE	DATE	BY
△	RELEASE	06/17	LH
△			
△			
△			

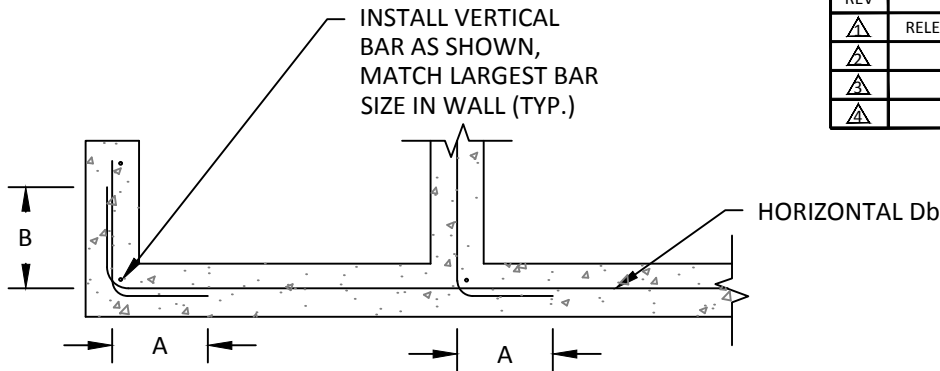

**SINGLE CURTAIN REINFORCEMENT (PLAN VIEW)**

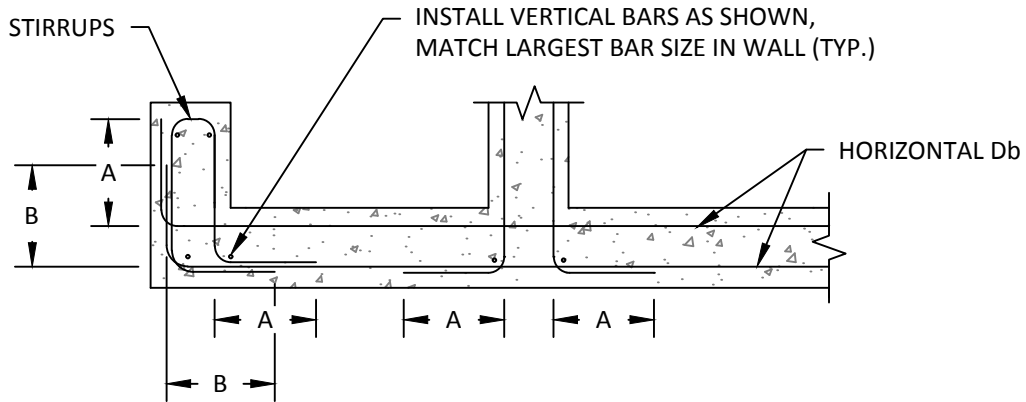

**DOUBLE CURTAIN REINFORCEMENT (PLAN VIEW)**

TYPICAL ANGLE/CORNER REINFORCEMENT							
BAR SIZE		#4	#5	#6	#7	#8	#9
GRADE 60	A	1'-6"	1'-6"	2'-0"	2'-9"	3'-7"	4'-6"
	B	1'-9"	2'-6"	3'-6"	4'-9"	6'-2"	7'-8"

MINIMUM CONCRETE COVER, 2006 IBC, SECTION 1907.7.1	
CONCRETE CAST AGAINST AND PERMANENTLY EXPOSED TO EARTH	3"
CONCRETE EXPOSED TO EARTH OR WEATHER	
NO. 5 BAR OR SMALLER	1-1/2"
NO. 6 BAR OR LARGER	2"
CONCRETE NOT EXPOSED TO WEATHER OR IN CONTACT WITH GROUND	
SLABS, WALLS AND JOISTS	3/4"
BEAMS AND COLUMNS	1-1/2"

Db = BAR DIAMETER  
D = FINISHED INSIDE BEND DIA  
D = 6Db FOR #3 THROUGH #8



**STEEL REINFORCEMENT**

DATE: JUNE 2017  
SCALE: NONE

STANDARD #: G 05  
SHEET 1 OF 2

APPROVED BY:

CHAD J. TIENKEN, P.E., P.L.S.  
CIVIL ENGINEERING MANAGER

DATE: 9/7/17

REV	CHANGE	DATE	BY
△	RELEASE	06/17	LH
△			
△			
△			

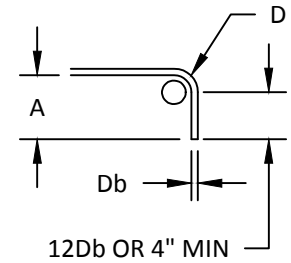
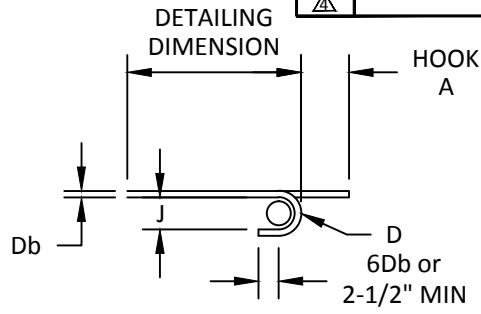
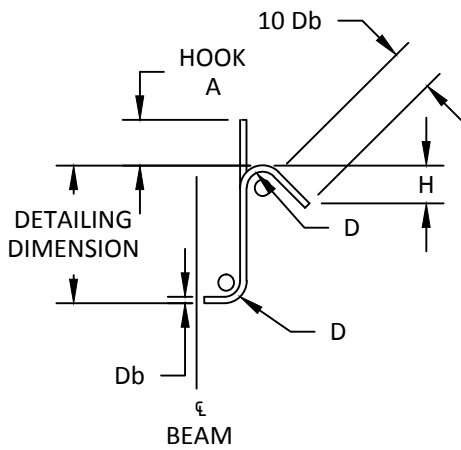

135° SEISMIC HOOK			
BAR SIZE	A	D	APPROX H
#3	5"	1-1/2"	3-1/2"
#4	6-1/2"	2"	4-1/2"
#5	8"	2-1/2"	5-1/2"
#6	11"	4-1/2"	6-1/2"
#7	12-1/2"	5-1/4"	7-3/4"
#8	14-1/2"	6"	9"

DIMENSIONS OF STANDARD 180° HOOKS			
BAR SIZE	A	J	D
#3	5"	3"	2-1/4"
#4	6"	4"	3"
#5	7"	5"	3-3/4"
#6	8"	6"	4-1/2"
#7	10"	7"	5-1/4"
#8	11"	8"	6"

DIMENSIONS OF STANDARD 90° HOOKS	
A	D
6"	2-1/4"
8"	3"
10"	3-3/4"
12"	4-1/2"
14"	5-1/4"
16"	6"

D = FINISHED INSIDE BEND DIA

### REINFORCEMENT BEND

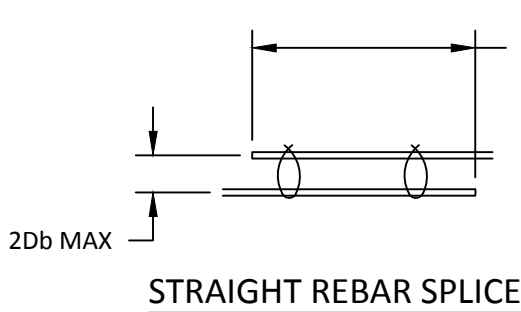

44Db FOR Db < #6  
55Db FOR Db > #7  
WIRED TOGETHER

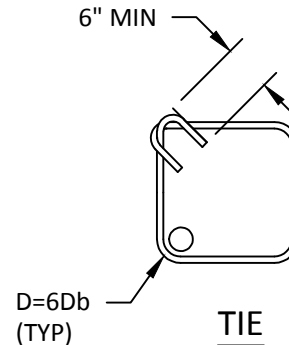

### REINFORCING STEEL NOTES

1. ALL REBAR SHALL BE GRADE 60.
2. SPLICES AND HOOKS MADE IN REINFORCING STEEL SHALL BE STAGGERED AND LAPPED IN ACCORDANCE WITH ACI-318.
3. SLAB REINFORCING SHALL BE LOCATED IN THE CENTER OF THE SLAB, UNLESS NOTED OTHERWISE.
4. ALL BARS SHALL BE FREE OF EXCESSIVE RUST, MUD, OIL, AND GREASE.



### STEEL REINFORCEMENT (CONT.)

DATE: JUNE 2017  
SCALE: NONE

STANDARD #: G 05  
SHEET 2 OF 2

APPROVED BY:

CHAD J. TIENKEN, P.E., P.L.S.  
CIVIL ENGINEERING MANAGER

DATE: 9/7/17

**CONSTRUCTION NOTES**

REV	CHANGE	DATE	BY
1	RELEASE	06/17	LH
2			
3			
4			

1. ALL OPENINGS (SQUARE AND CIRCULAR)
  - A. INSTALL ADDITIONAL HORIZONTAL AND VERTICAL REINFORCEMENT ABOVE, BELOW, AND TO EACH SIDE OF THE OPENING. ADDITIONAL STEEL AREA SHALL BE EQUAL TO THE STEEL AREA CUT BY THE OPENING, AND SHALL BE EVENLY DIVIDED EACH SIDE OF THE OPENING. ALL CUT BARS SHALL BE CUT 2 INCHES FROM THE OPENING.
  - B. ADDITIONAL BARS SHALL BE INSTALLED WITHIN 2 WALL THICKNESSES OF THE OPENING (INCREASE BAR SIZE AS REQUIRED). MAINTAIN MINIMUM 2 INCHES CLEARANCE BETWEEN BARS. IF THE OPENING IS WITHIN 1 WALL THICKNESS OF AN INTERSECTING (PERPENDICULAR) SLAB OR WALL, THE ADDITIONAL REINFORCEMENT ADJACENT TO INTERSECTING SLAB OR WALL MAY BE OMITTED.
  - C. OPENINGS LESS THAN 12 INCHES IN DIAMETER OR MAXIMUM WIDTH DO NOT REQUIRE ADDITIONAL HORIZONTAL AND VERTICAL REINFORCEMENT, BUT ADDITIONAL DIAGONAL BARS OR HOOPS SHALL BE INSTALLED AROUND CIRCULAR OPENINGS AS SPECIFIED IN NOTE 2, BELOW.
  - D. FOR MINIMUM LAP LENGTHS, REFER TO M.I.D. STANDARD G 05 - STEEL REINFORCEMENT\*. EXTEND REBAR INTO ADJACENT WALLS/SLABS AS REQUIRED TO MAINTAIN MINIMUM LAP LENGTHS. REFER TO M.I.D. STANDARD G 05 FOR HOOK REQUIREMENTS.
  - E. REINFORCEMENT SHALL BE PLACED IN THE CENTER OF WALLS AND SLABS UNLESS SPECIFIED OTHERWISE.
2. CIRCULAR OPENINGS ONLY
  - A. INSTALL ADDITIONAL HORIZONTAL AND VERTICAL REINFORCEMENT AS SPECIFIED IN NOTE 1, ABOVE.
  - B. INSTALL EITHER DIAGONAL BARS OR HOOPS AS FOLLOWS:
    - 1) DIAGONAL BARS: INSTALL 4 DIAGONAL BARS PER MAT OF STEEL. DIAGONAL BAR SIZE SHALL MATCH THE LARGEST BAR SIZE IN THE WALL OR SLAB. DIAGONAL BARS MAY BE BENT AND LAPPED WITH ADJACENT BARS NEAR INTERSECTING SLABS, WALLS, OR OTHER OBSTRUCTIONS.
    - 2) HOOPS: INSTALL 1 HOOP PER MAT OF STEEL. HOOP SIZE SHALL BE ONE BAR SIZE GREATER THAN THE LARGEST BAR SIZE IN THE WALL OR SLAB.
3. ALL STEEL REINFORCEMENT SHALL CONFORM TO APPLICABLE PROVISIONS OF ACI-318.

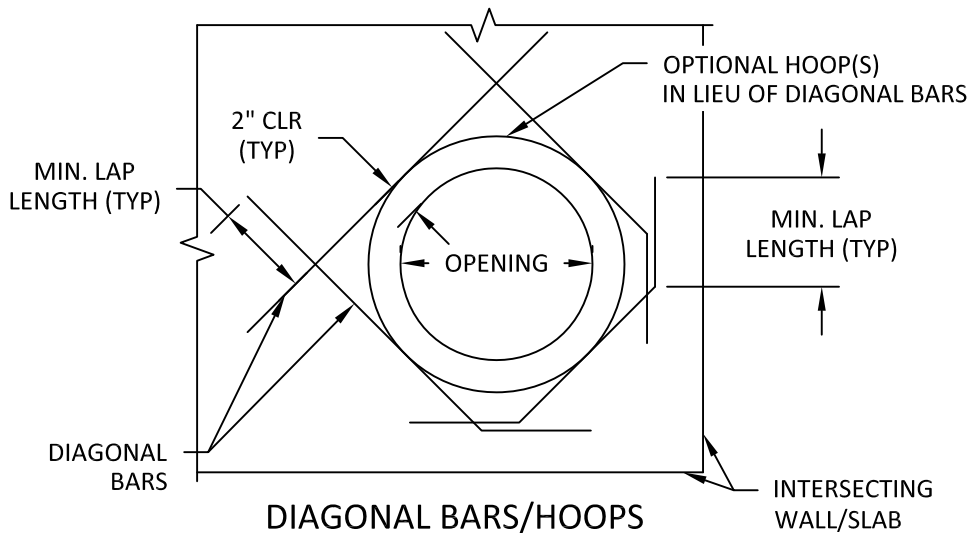
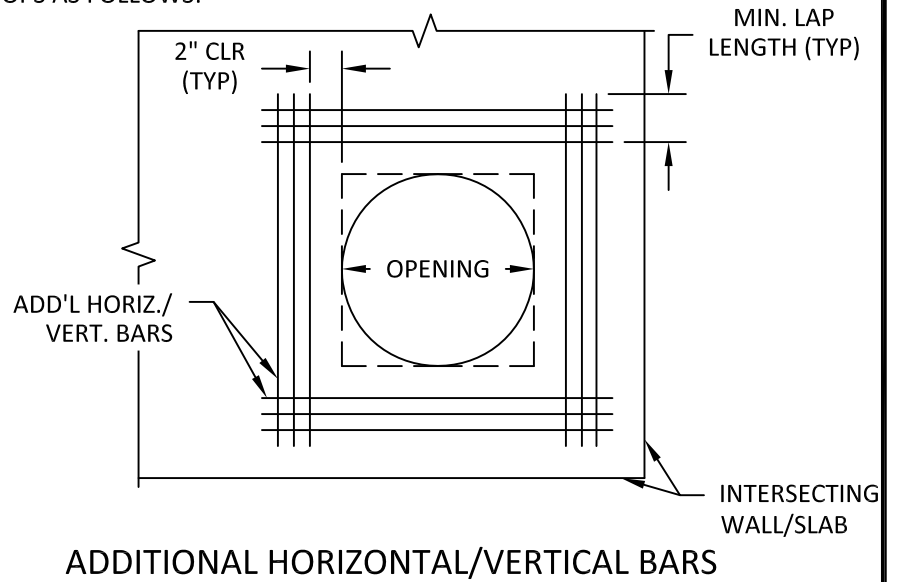

\*REFERENCED STANDARD(S): G 05



**OPENING REINFORCEMENT**

DATE: JUNE 2017

STANDARD #:

G 06

SCALE: NONE

APPROVED BY:

CHAD J. TIENKEN, P.E., P.L.S.  
CIVIL ENGINEERING MANAGER

DATE: 9/7/17

REV	CHANGE	DATE	BY
1	RELEASE	06/17	LH
2			
3			
4			

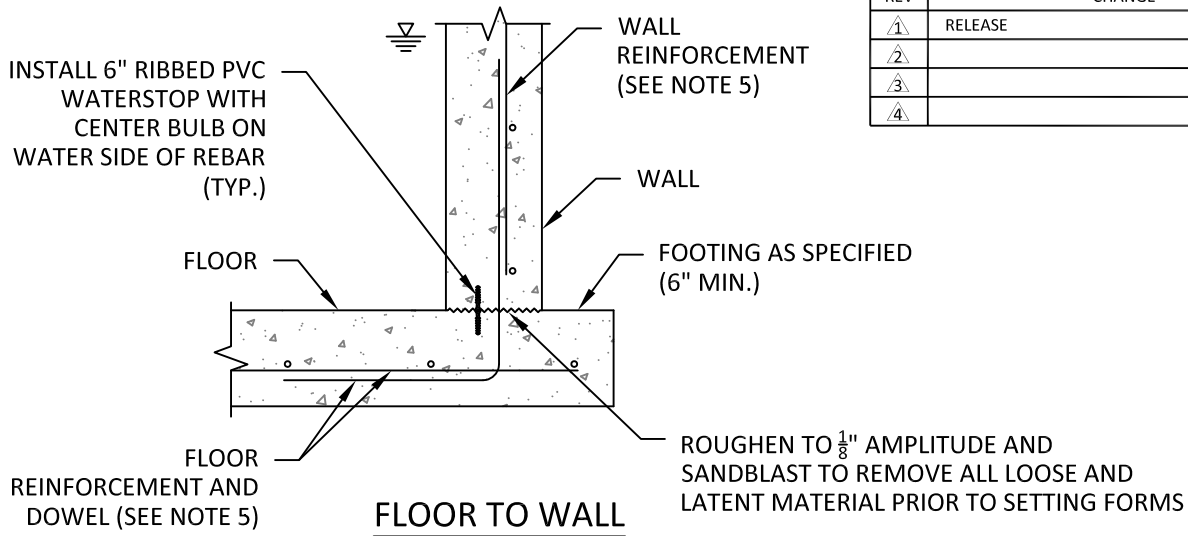

**FLOOR TO WALL**

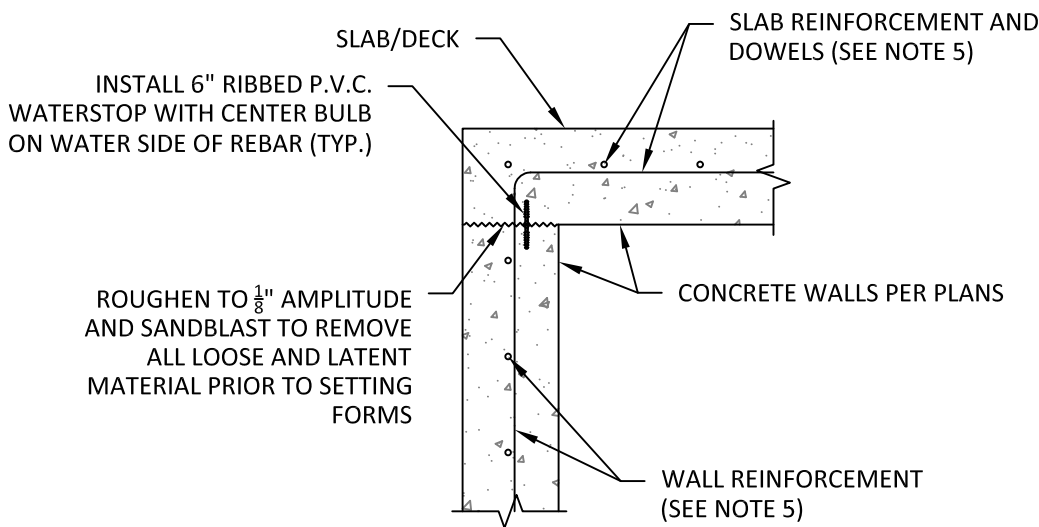

**WALL TO SLAB**

**NOTES:**

1. ALL JOINTS BETWEEN CONCRETE POURS SHALL BE APPROVED CONSTRUCTION JOINTS. ALL CONSTRUCTION JOINTS SHALL CONFORM TO THIS STANDARD AND M.I.D. STANDARD G 04 - CONCRETE NOTES\*.
2. CONSTRUCTION JOINTS ARE REQUIRED FOR ALL FLOOR/SLAB TO WALL TRANSITIONS.
3. CONSTRUCTION JOINTS SHALL BE PLACED AS SHOWN ON THE PLANS OR AS PRE-APPROVED BY M.I.D. ENGINEER. JOINTS SHALL BE THOROUGHLY CLEANED AND LAITANCE REMOVED BEFORE A NEW POUR IS MADE. EACH JOINT SHALL BE WETTED IMMEDIATELY BEFORE THE PLACING OF NEW CONCRETE.
4. WATERSTOP SHALL BE 6 INCH RIBBED PVC WATERSTOP WITH CENTER BULB.
5. REINFORCING STEEL SHALL JOIN THE CONCRETE BETWEEN POURS WITH A MINIMUM OVERLAP CONFORMING TO M.I.D. STANDARD G 05 - STEEL REINFORCEMENT\*.
6. THIS DETAIL INTENTIONALLY DOES NOT SPECIFY CONCRETE THICKNESS OR REINFORCEMENT SIZE WHICH SHOULD BE DESIGNED SEPARATELY.

\*REFERENCED STANDARD(S): G 04, G 05



**NEW CONSTRUCTION JOINT**

DATE: JUNE 2017

STANDARD #:

G 07

SCALE: NONE

APPROVED BY:

CHAD J. TIENKEN, P.E., P.L.S.  
CIVIL ENGINEERING MANAGER

DATE: 9/7/17

REV	CHANGE	DATE	BY
△	RELEASE	06/17	LH
△	REVISED	04/22	LH
△			
△			

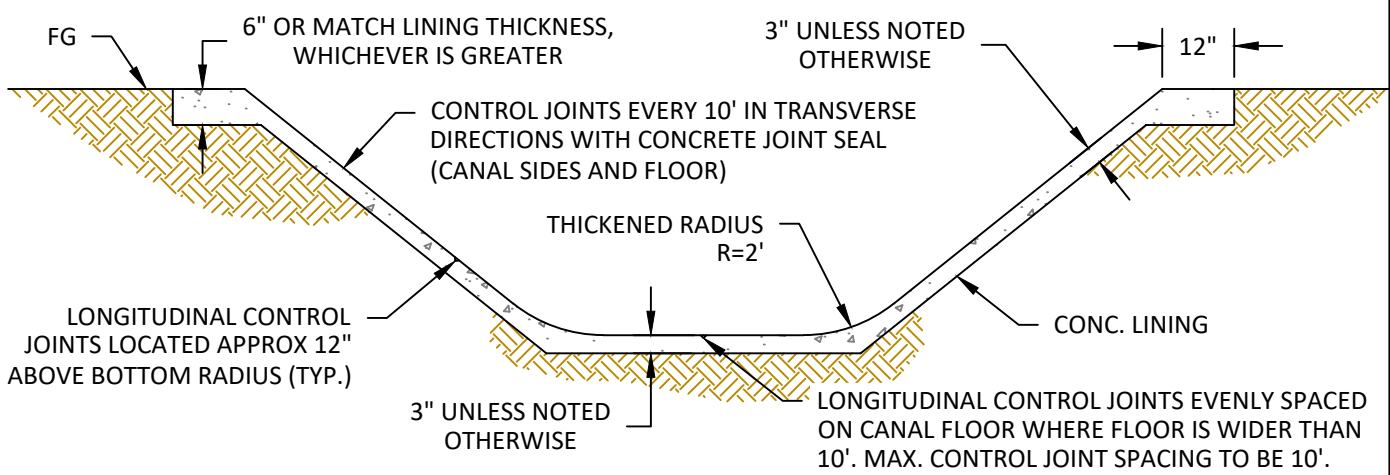
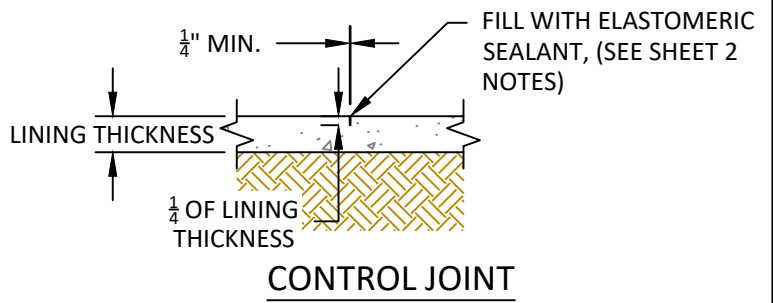
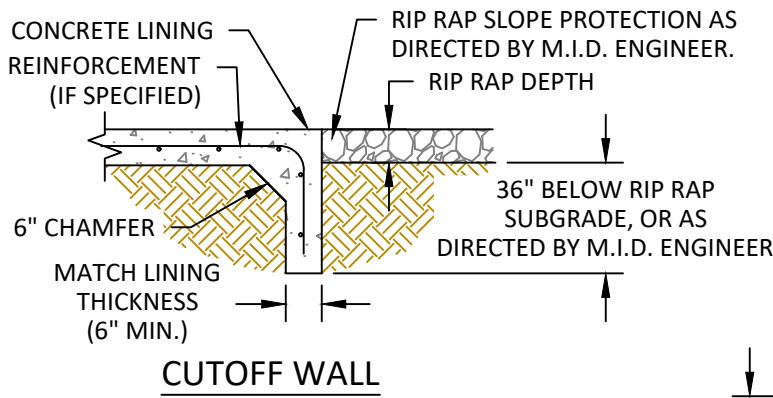
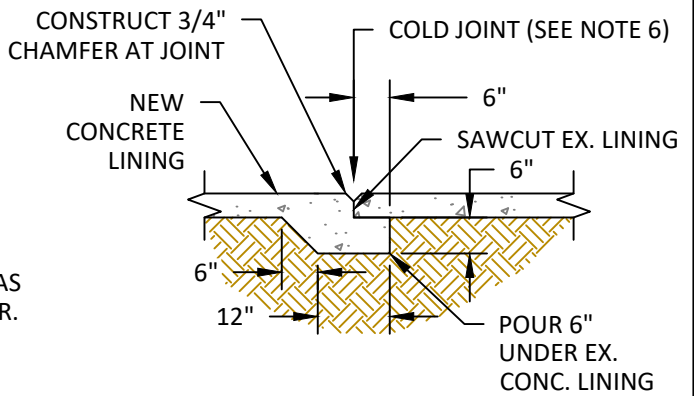
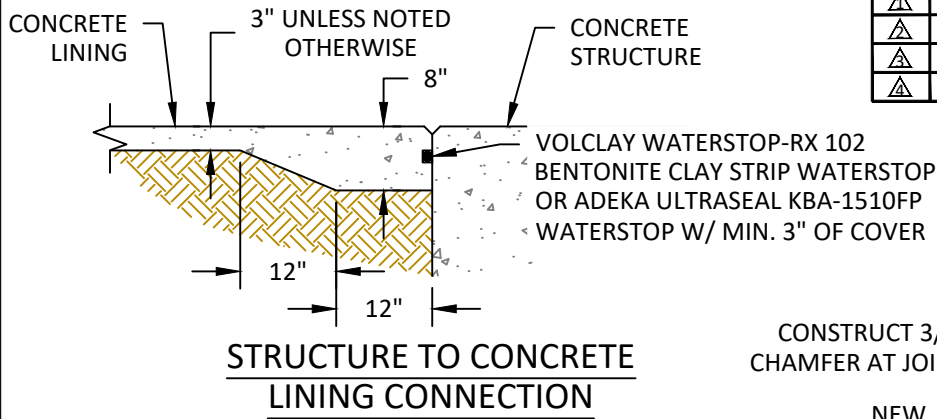

CONCRETE LINED CANAL DETAILS	
DATE: JUNE 2017	STANDARD #: G 08
SCALE: NONE	SHEET 1 OF 2

APPROVED BY:  
*David B. Bakker*  
 DAVID B. BAKKER, P.E.  
 SENIOR CIVIL ENGINEER  
 DATE: 4/29/22



**NOTES:**

REV	CHANGE	DATE	BY
△	RELEASE	06/17	LH
△	REVISED	04/22	LH
△			
△			

1. ALL WATERSTOPS SHALL HAVE MINIMUM 3 INCHES CONCRETE COVER ON ALL SIDES.
2. BACKFILL AND SUBGRADES SHALL BE COMPACTED TO MINIMUM 90% RELATIVE DENSITY PER ASTM D-1557 AND SHALL BE MANUALLY COMPACTED A MINIMUM OF 8 INCHES OVER TOP OF PIPE OR AS DIRECTED BY M.I.D. ENGINEER. SEE M.I.D. STANDARD G 09 - TRENCH BACKFILL\*.
3. CONTROL JOINT DEPTH SHALL BE MINIMUM 1/4 OF LINING THICKNESS AND 1/4 INCH WIDE AS SHOWN IN THE CONTROL JOINT DETAIL, SHEET 1 AND SHALL BE LOCATED EVERY 10 FEET IN THE TRANSVERSE DIRECTION AND LONGITUDINALLY APPROXIMATELY 12 INCHES ABOVE THE BOTTOM RADIUS ON BOTH SIDES (SEE SHEET 1 DETAILS).
4. TRANSITIONS
  - A. CONCRETE LINED CANALS:  
SAWCUT EXISTING LINING AT A LOCATION APPROVED BY AND AS DIRECTED BY M.I.D. ENGINEER. UNDERLAP EXISTING LINING A MINIMUM OF 6 INCHES UNDER THE SAWCUT EDGE (BOTH SIDES AND BOTTOM) AS SHOWN IN THE CONNECTION TO EXISTING LINING DETAIL, SHEET 1. DAMAGE TO THE EXISTING CONCRETE LINING WILL REQUIRE REPAIR OR REPLACEMENT AS DIRECTED BY M.I.D. ENGINEER.
  - B. EARTHEN CANAL:  
NEW LINING SIDE SLOPES SHALL MATCH EXISTING CANAL SIDE SLOPES, OR AS DIRECTED BY M.I.D. ENGINEER. SIDE SLOPES SHALL BE NO STEEPER THAN 1-1/2 HORIZONTAL TO 1 VERTICAL UNLESS PRE-APPROVED BY M.I.D. ENGINEER. SIDE SLOPES SHALL BE FEATHERED BACK TO MATCH THE EXISTING CANAL BANKS FOR 10 LINEAR FEET UPSTREAM AND DOWNSTREAM OF THE CONCRETE LINING TRANSITION, OR AS DIRECTED BY M.I.D. ENGINEER. RIP RAP OR CONCRETE LINING SLOPE PROTECTION SHALL BE INSTALLED AS DIRECTED BY M.I.D. ENGINEER.
5. CONCRETE LINING SHALL BE POURED IN PLACE, AT MINIMUM 3 INCHES THICK. CEMENT SHALL BE TYPE II PORTLAND CEMENT. LINING CONCRETE SHALL HAVE A MINIMUM 28 DAY COMPRESSIVE STRENGTH OF 2,500 PSI. SLUMP SHALL BE A MAXIMUM OF 4 INCHES. CONCRETE SHALL BE PREVENTED FROM DRYING FOR A CURING PERIOD OF AT LEAST 7 DAYS AFTER IT IS PLACED. EXPOSED SURFACES SHALL BE KEPT CONTINUOUSLY MOIST FOR THE ENTIRE PERIOD, OR AN APPROVED CURING COMPOUND SHALL BE APPLIED AFTER FINISHING AT A RATE OF ONE GALLON PER 150 SQUARE FEET. REINFORCEMENT SHALL BE EITHER FIBERMESH "MD" AT 2.0 POUNDS PER CUBIC YARD OF CONCRETE OR 6"x6"-W2.1xW2.1 WELDED WIRE FABRIC AS DIRECTED BY M.I.D. ENGINEER.
6. ALL COLD JOINT INTERFACES BETWEEN CONCRETE SURFACES SHALL BE FILLED WITH BACKER ROD AND SIKAFLEX 1A ELASTOMERIC SEALANT OR PRE-APPROVED EQUIVALENT. CONCRETE SHALL CURE FOR AT LEAST 72 HOURS PRIOR TO SEALANT PLACEMENT. CLEAN OUT GAP PRIOR TO SEALANT PLACEMENT AND APPLY ACCORDING TO PRODUCT MANUFACTURER REQUIREMENTS. SEALANT SHALL FILL JOINT COMPLETELY. WHEN APPROVED BY M.I.D. ENGINEER, SEAL JOINT BY USING BRISTLE BRUSH TO BLEND NEW CONCRETE TO EXISTING LINING IN PLACE OF ELASTOMERIC SEALANT.
7. SHOTCRETE LINING MAY BE INSTALLED AS AN ALTERNATIVE TO CONCRETE LINING. DESIGN MIX SHALL BE PRE-APPROVED BY M.I.D. ENGINEER.
8. STRUCTURE TO LINING CONNECTIONS MAY REQUIRE REBAR DOWELS AS DIRECTED BY M.I.D. ENGINEER.

\*REFERENCED STANDARD(S): G 09



CONCRETE LINED CANAL NOTES

DATE: JUNE 2017

STANDARD #:

G 08

SCALE: NONE

SHEET 2 OF 2

APPROVED BY:

*David B. Bakker*

DAVID B. BAKKER, P.E.  
SENIOR CIVIL ENGINEER

DATE: 4/29/22

REV	CHANGE	DATE	BY
1	RELEASE	06/17	LH
2	REVISED	04/22	LH
3			
4			

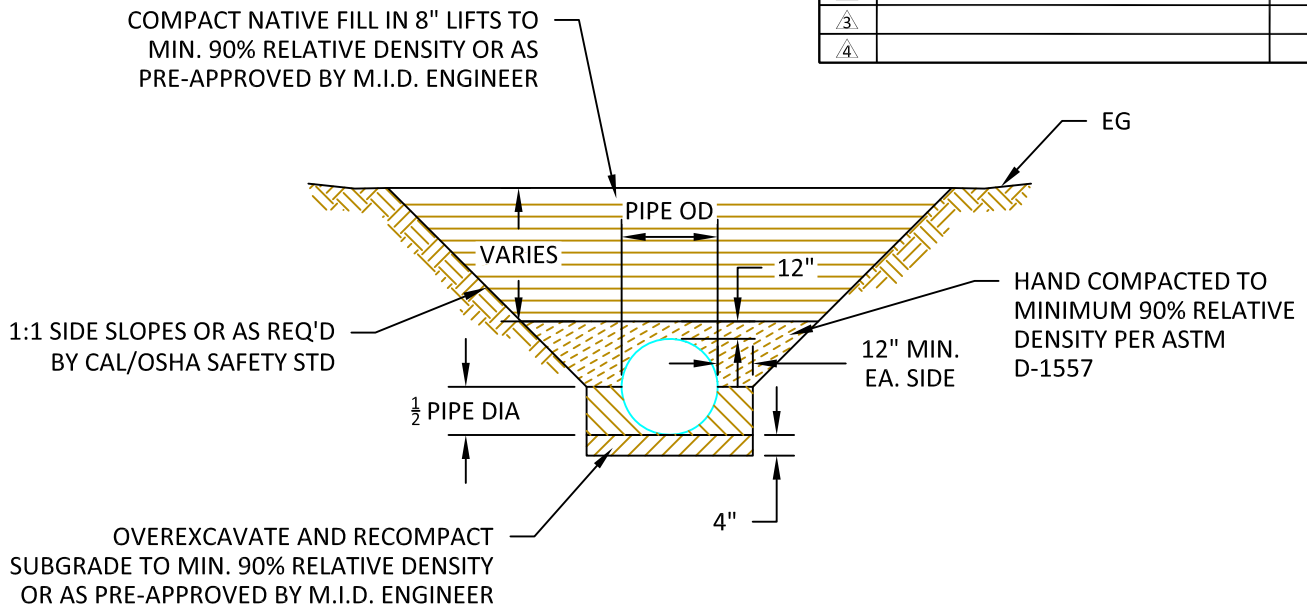

**NOTES:**

- BACKFILL AND SUBGRADES SHALL BE COMPACTED TO MINIMUM 90% RELATIVE DENSITY PER ASTM D-1557 AND SHALL BE MANUALLY COMPACTED A MINIMUM DEPTH OF 12 INCHES OVER TOP OF PIPE OR AS DIRECTED BY M.I.D. ENGINEER. THE MAXIMUM LAYER THICKNESS SHALL BE 8 INCHES BEFORE COMPACTION.
- BACKFILL SHALL BE SELECT NATIVE MATERIAL, CONTAIN NO MATERIAL OVER 3 INCHES IN DIAMETER OR LENGTH, AND SHALL BE COMPACTED AGAINST UNDISTURBED EARTH. FILL MATERIAL SHALL CONTAIN NO SOD, BRUSH, ROOTS, OR OTHER ORGANIC OR OTHERWISE UNSUITABLE MATERIAL.
- PIPELINE SHALL BE INSTALLED ACCORDING TO MANUFACTURER INSTRUCTIONS AND SPECIFICATIONS. MINIMUM DEPTH OF COVER SHALL BE 30 INCHES OR AS DIRECTED BY M.I.D. ENGINEER.
- COMPACTION TESTS SHALL BE AT THE CONTRACTOR'S EXPENSE. FREQUENCY AND LOCATION OF THE TESTS SHALL BE AS DIRECTED BY M.I.D. ENGINEER.
- DEWATERING DUE TO HIGH GROUNDWATER OR CANAL SEEPAGE MAY BE REQUIRED. DEWATERING METHODS SHALL BE PRE-APPROVED BY M.I.D. ENGINEER PRIOR TO COMMENCEMENT.
- TRENCH WIDTHS SHALL BE AS SHOWN UNLESS THE PIPELINE SIZE IS 4 INCHES OR SMALLER, WHERE THE TRENCH SHALL HAVE A 12 INCH MINIMUM WIDTH.
- BEDDING, IF REQUIRED, SHALL BE MINIMUM 4 INCHES AS PRE-APPROVED BY M.I.D. ENGINEER. BEDDING SHALL CONFORM TO THE SPECIFICATIONS BELOW:
  - ON SANDY SOIL (BEDDING & HAUNCHING);  
NATIVE MATERIAL, IF SUITABLE, OR SAND AS PRE-APPROVED BY M.I.D. ENGINEER
  - ON CLAY SOIL (BEDDING & HAUNCHING);  
SAND OR NATIVE MATERIAL AS PRE-APPROVED BY M.I.D. ENGINEER
- FLOODING OR JETTING SHALL ONLY BE USED ON SOILS PRE-APPROVED BY M.I.D. ENGINEER. WHEN FLOODING OR JETTING IS USED, THE AMOUNT OF WATER SHALL BE CONTROLLED TO INSURE THAT POOLING OF EXCESS WATER DOES NOT OCCUR. THE WETTED FILL MUST BE ALLOWED TO REACH OPTIMUM MOISTURE AND THEN MECHANICALLY COMPACTED TO MEET MINIMUM 90% RELATIVE DENSITY PER ASTM D-1557 BEFORE ADDITIONAL BACKFILLING IS DONE. CARE MUST BE EXERCISED TO PREVENT PIPE FLOTATION DURING FLOODING OR JETTING. MEASURES MUST BE PRE-APPROVED BY M.I.D. ENGINEER. NO FLOODING OR JETTING SHALL BE ALLOWED FOR P.C.V. OR HDPE PIPELINES.



**TRENCH BACKFILL**

DATE: JUNE 2017

STANDARD #:

G 09

SCALE: NONE

APPROVED BY:

*David B. Bakker*

DAVID B. BAKKER, P.E.  
SENIOR CIVIL ENGINEER

DATE: 4/29/22

REV	CHANGE	DATE	BY
1	RELEASE	06/17	LH
2			
3			
4			

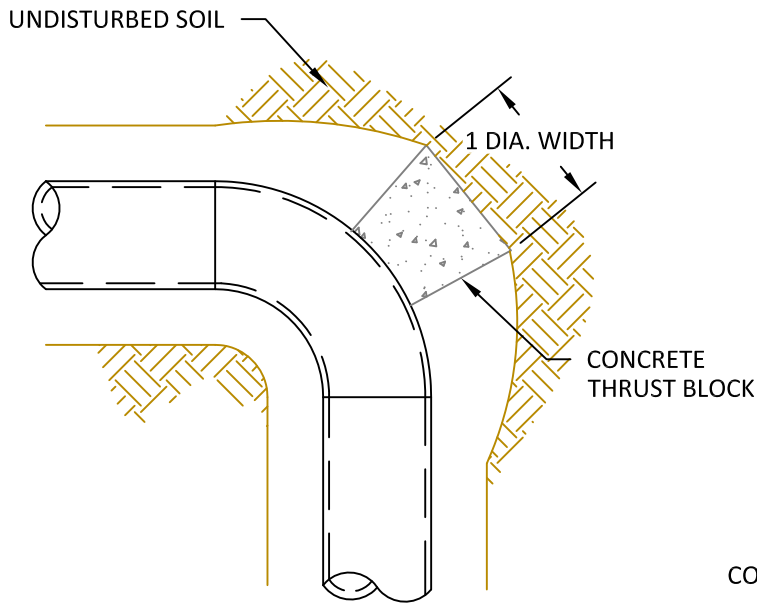

**ELBOW PLAN**

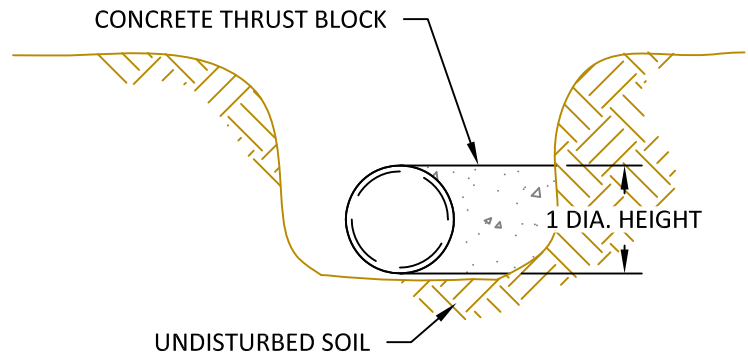

**THRUST BLOCK PROFILE**

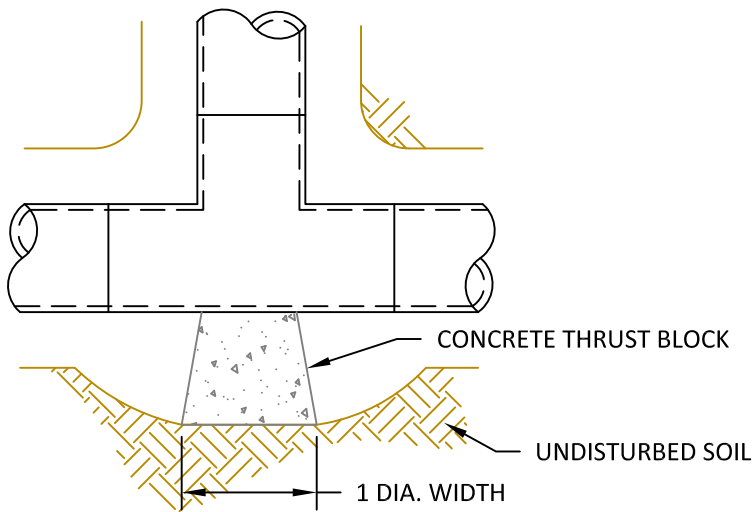

**TEE PLAN**

**NOTES:**

1. MAXIMUM WORKING PRESSURE: 7.5 PSI
2. MAXIMUM PIPE HEAD: 17 FEET
3. FOR GRAVITY FLOW PIPES ONLY
4. MUST BE AGAINST UNDISTURBED SOIL
5. ALL STEEL FITTINGS SHALL BE WRAPPED WITH 4 MIL POLYETHYLENE SHEETING AND SECURED WITH P.V.C. TAPE. CONCRETE SHALL NOT ENCROACH ON END FITTINGS.



**CONCRETE PIPE THRUST BLOCK**

DATE: JUNE 2017

STANDARD #:

G 10

SCALE: NONE

APPROVED BY:

CHAD J. TIENKEN, P.E., P.L.S.  
CIVIL ENGINEERING MANAGER

DATE: 9/7/17

M.I.D. STANDARD MORTAR MIX (PREFERRED MORTAR MIX)

REV	CHANGE	DATE	BY
1	RELEASE	06/17	LH
2			
3			
4			

QUANTITY	DESCRIPTION
1	94LB BAG OF PORTLAND CEMENT
7	FULL SHOVELS OF SAND
2	FULL SHOVELS OF FIRECLAY

1. THE M.I.D. STANDARD MORTAR MIX MUST BE THOROUGHLY DRY MIXED BEFORE ADDING WATER.
2. USE A SOFT BRISTLE BRUSH TO BOND MORTAR AND EXISTING CONCRETE TOGETHER.
3. ALL MORTARED JOINTS AND REPAIRS EXPOSED TO SUNLIGHT MUST BE WRAPPED IN PLASTIC TO PREVENT CRACKING.
4. A MINIMUM OF 48 HOURS CURING TIME IS REQUIRED.

OTHER STANDARD DRYING MORTAR MIXES (ACCEPTABLE)

1. ALL MANUFACTURED MORTAR MIX PRODUCTS SHALL HAVE CONSISTENT MIX PROPERTIES AS THE M.I.D. STANDARD MORTAR MIX. ALL MANUFACTURED MORTAR MIX PRODUCTS DRYING TIME MUST BE CONSISTENT WITH THE MANUFACTURERS RECOMMENDATIONS, BUT NOT LESS THAN 48 HOURS.
2. FOLLOW ALL MANUFACTURER GUIDELINES TO CREATE A SMOOTH SEALED BOND.
3. FOLLOW ALL MANUFACTURER GUIDELINES FOR PROPER SURFACE PREPARATION BEFORE MORTARING.

QUICK DRYING MORTAR PRODUCTS (ACCEPTABLE ONLY WHEN APPROVED)

1. USE ONLY CUSTOM-PLUG HYDRAULIC PATCHING AND ANCHORING CEMENT OR A PRE-APPROVED EQUIVALENT PRODUCT ONLY IN SITUATIONS WHERE 48 HOURS OF CURING TIME IS NOT POSSIBLE.
2. ALL MANUFACTURED QUICK DRYING MORTAR MIX PRODUCTS MUST BE PRE-APPROVED BY M.I.D. ENGINEER.
3. FOLLOW ALL MANUFACTURER GUIDELINES TO CREATE A SMOOTH SEALED BOND.
4. FOLLOW ALL MANUFACTURER GUIDELINES FOR PROPER SURFACE PREPARATION BEFORE MORTARING.



M.I.D. MORTAR MIX NOTES

DATE: JUNE 2017

STANDARD #:

G 11

SCALE: NONE

APPROVED BY:

CHAD J. TIENKEN, P.E., P.L.S.  
CIVIL ENGINEERING MANAGER

DATE: 9/7/17

REV	CHANGE	DATE	BY
1	RELEASE	06/17	LH
2			
3			
4			

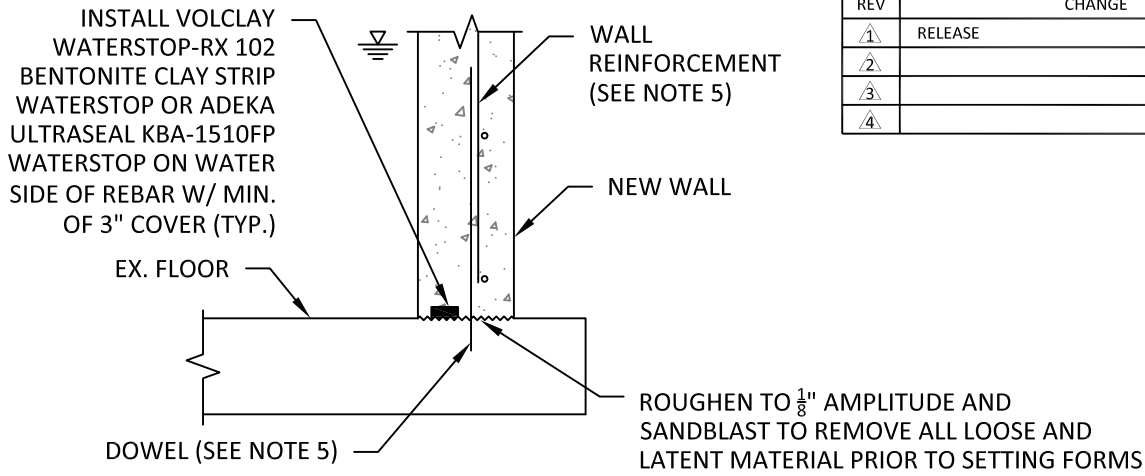

**EXISTING FLOOR TO NEW WALL**

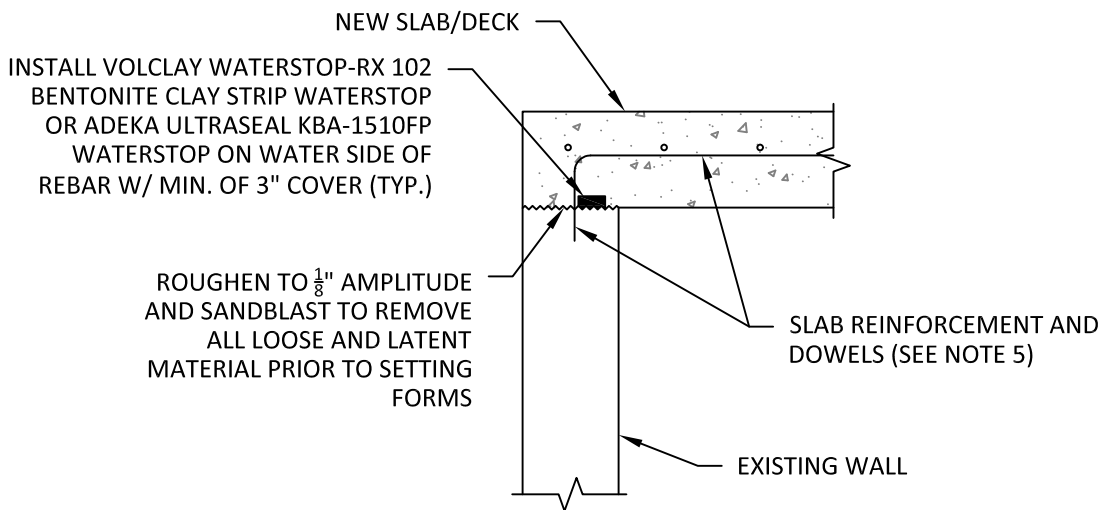

**EXISTING WALL TO NEW SLAB**

**NOTES:**

1. ALL JOINTS BETWEEN CONCRETE POURS SHALL BE APPROVED CONSTRUCTION JOINTS. ALL CONSTRUCTION JOINTS SHALL CONFORM TO THIS STANDARD AND M.I.D. STANDARD G 04 - CONCRETE NOTES\*.
2. CONSTRUCTION JOINTS ARE REQUIRED FOR ALL FLOOR/SLAB TO WALL TRANSITIONS.
3. CONSTRUCTION JOINTS SHALL BE PLACED AS SHOWN ON THE PLANS OR AS PRE-APPROVED BY M.I.D. ENGINEER. JOINTS SHALL BE THOROUGHLY CLEANED AND LAITANCE REMOVED BEFORE A NEW POUR IS MADE. EACH JOINT SHALL BE WETTED IMMEDIATELY BEFORE THE PLACING OF NEW CONCRETE.
4. WATERSTOP SHALL BE VOLCLAY WATERSTOP - RX 102 BENTONITE CLAY STRIP WATERSTOP OR ADEKA ULTRASEAL KBA-1510FP WATERSTOP.
5. REINFORCING STEEL SHALL JOIN THE CONCRETE BETWEEN POURS WITH A MINIMUM OVERLAP CONFORMING TO M.I.D. STANDARD G 05 - STEEL REINFORCEMENT\*.
6. THIS DETAIL INTENTIONALLY DOES NOT SPECIFY CONCRETE THICKNESS OR REINFORCEMENT SIZE WHICH SHOULD BE DESIGNED SEPARATELY.

\*REFERENCED STANDARD(S): G 04, G 05



CONNECTION TO EXISTING STRUCTURE	
DATE: JUNE 2017	STANDARD #: G 12
SCALE: NONE	

APPROVED BY:   
 CHAD J. TIENKEN, P.E., P.L.S.  
 CIVIL ENGINEERING MANAGER  
 DATE: 9/7/17

**CONSTRUCTION NOTES:**

REV	CHANGE	DATE	BY
1	RELEASE	06/17	LH
2	REVISED	04/22	LH
3			
4			

1. CONCRETE STRENGTH TO BE 3,000 PSI @ 28 DAYS. NO ADMIXTURES SHALL BE INCORPORATED INTO CONCRETE MIX UNLESS PRE-APPROVED BY M.I.D. SEE M.I.D. STANDARD G 04 - CONCRETE NOTES\*.
2. ALL PIPE SHALL ENTER HEADWALL AT OR NEAR PERPENDICULAR ANGLES TO THE HEADWALL.
3. SEE M.I.D. STANDARD G 08 - CONCRETE LINED CANAL NOTES\* FOR LINING REPAIR.
4. ALL COLD JOINTS REQUIRE 6" CENTER BULB RUBBER WATER STOP EMBEDDED IN CENTER OF WALL AT COLD JOINT LOCATION PER MANUFACTURER'S RECOMMENDATIONS. SEE M.I.D. STANDARD G 07 - NEW CONSTRUCTION JOINT\*.
5. GATE FRAME SHALL BE SECURELY BOLTED TO CONCRETE STRUCTURE WITH STAINLESS STEEL BOLTS. TOP ANCHORS SHALL BE INSTALLED WITHIN 8 TO 12 INCHES BELOW THE TOP OF CONCRETE WALL.
6. CANAL GATES SHALL BE WATERMAN C-10 CANAL GATE OR PRE-APPROVED EQUIVALENT WITH GALVANIZED FRAME.
7. SITE CONDITIONS MAY REQUIRE ADDITIONAL CUTOFF WALLS AND/OR COLLARS TO PREVENT SEEPAGE OR SLIDING, AS DIRECTED BY M.I.D.
8. UPSTREAM SUBMERGENCE SHOULD BE AT LEAST ONE PIPE DIAMETER ABOVE TOP OF PIPE.
9. SUFFICIENT SUBMERGENCE MUST OCCUR DOWNSTREAM TO ENSURE FULL PIPE FLOW SUCH THAT A READABLE WATER SURFACE IS PRESENT IN THE DOWNSTREAM AIR VENT (MINIMUM ONE FOOT ABOVE TOP OF PIPE DESIRED).
10. THE DIFFERENCE BETWEEN UPSTREAM AND DOWNSTREAM WATER SURFACE ELEVATIONS SHALL BE 12"-18" MAXIMUM.
11. THE GATE DISCHARGE TABLE BEING USED SHOULD BE VERIFIED TO ENSURE THAT IT APPLIES TO THE CONDITIONS ENCOUNTERED IN THE FIELD AND TO THE BRAND AND TYPE OF GATE BEING USED.
12. DISCHARGE TABLES FOR ROUND BOTTOM GATES MUST NOT BE USED FOR SQUARE BOTTOM GATES AND VICE VERSA. GATE SETTINGS MUST BE MADE AND READ ACCURATELY, WHICH REQUIRES THAT THE GATE POSITION INDICATORS BE IN GOOD CONDITION AND INDICATE THE TRUE OPENING.
13. STILLING WELLS AND VENTS SHALL BE PERIODICALLY FLUSHED TO MAKE SURE THEY ARE OPERATING PROPERLY AND ARE FREE OF OBSTRUCTIONS AND SILT. WEEDS, TRASH, AND SEDIMENT MUST BE REMOVED FROM THE APPROACH TO THE GATE BECAUSE THEY CAN CAUSE FLOW DISTURBANCES THAT MAY RESULT IN ERRONEOUS HEAD DIFFERENTIAL READINGS.
14. ALL VENT PIPE COVERS MUST BE REMOVABLE.
15. PROPERLY SEAL ALL HEADWALL JOINTS AND PIPES BY MORTARING. USE SOFT BRISTLE BRUSH TO BLEND MORTAR AND CONCRETE TOGETHER. SEE M.I.D. STANDARD G 11 - M.I.D. MORTAR MIX NOTES\*.
16. WATERSTOP SURROUNDING OPENINGS SHALL BE VOLCLAY WATERSTOP-RX 102 BENTONITE CLAY STRIP OR ADEKA ULTRASEAL KBA-1510FP WATERSTOP, PLACED AROUND OUTSIDE OF PIPE (CONCRETE) OR STARTER COUPLER (P.V.C.) IN CENTER OF WALL.

\*REFERENCED STANDARD(S): G 04, G 07, G 08, G 11



**STANDARD CANAL GATE NOTES**

DATE: JUNE 2017

STANDARD #:

G 13

SCALE: NONE

APPROVED BY:

*David B. Bakker*

DAVID B. BAKKER, P.E.  
SENIOR CIVIL ENGINEER

DATE: 4/29/22

**NOTES:**

1. CONCRETE STRENGTH TO BE 3,000 PSI @ 28 DAYS. NO ADMIXTURES SHALL BE INCORPORATED INTO CONCRETE MIX UNLESS PRE-APPROVED BY M.I.D. SEE M.I.D. STANDARD G 04 - CONCRETE NOTES\*.
2. THOROUGHLY BRUSH ALL DEBRIS AND CLEAN EACH END OF PIPE AROUND THE ENTIRE CIRCUMFERENCE WITH WATER PRIOR TO PLACEMENT OF CONCRETE OR MORTAR.
3. REINFORCED COLLAR REQUIRED FOR ALL PIPELINES GREATER THAN 18" INSIDE DIAMETER OR FOR PIPE CONNECTIONS WITH A CHANGE IN DIAMETER GREATER THAN 5".
4. MINIMUM #4 BARS FOR ALL COLLAR REINFORCEMENT.
5. A MINIMUM OF TWO CIRCUMFERENCE BARS REQUIRED, ONE BAR TO BE PLACED OVER THE END OF EACH PIPE WITH A MINIMUM 18" BAR LAP. THE BARS MUST HAVE A MINIMUM OF 3" CLEAR FROM EACH PIPE O.D. AND 2" MINIMUM OF CONCRETE COVER.
6. HORIZONTAL BARS SHALL BE PLACED AT 12" O.C. EQUALLY SPACED AROUND THE CIRCUMFERENCE OF THE PIPE WITH A MINIMUM OF SIX (6) HORIZONTAL BARS.
7. PROPERLY SEAL CONNECTION BY MORTARING FROM INSIDE PIPELINE AFTER PERMANENT PLACEMENT OF CONCRETE COLLAR AND PIPE SECTIONS. A MINIMUM MORTARED BAND WIDTH OF 5" IS REQUIRED. USE SOFT BRISTLE BRUSH TO BLEND MORTAR AND CONCRETE TOGETHER. SEE M.I.D. STANDARD G 11 - M.I.D. MORTAR MIX NOTES\*.

REV	CHANGE	DATE	BY
1	RELEASE	06/17	LH
2			
3			
4			

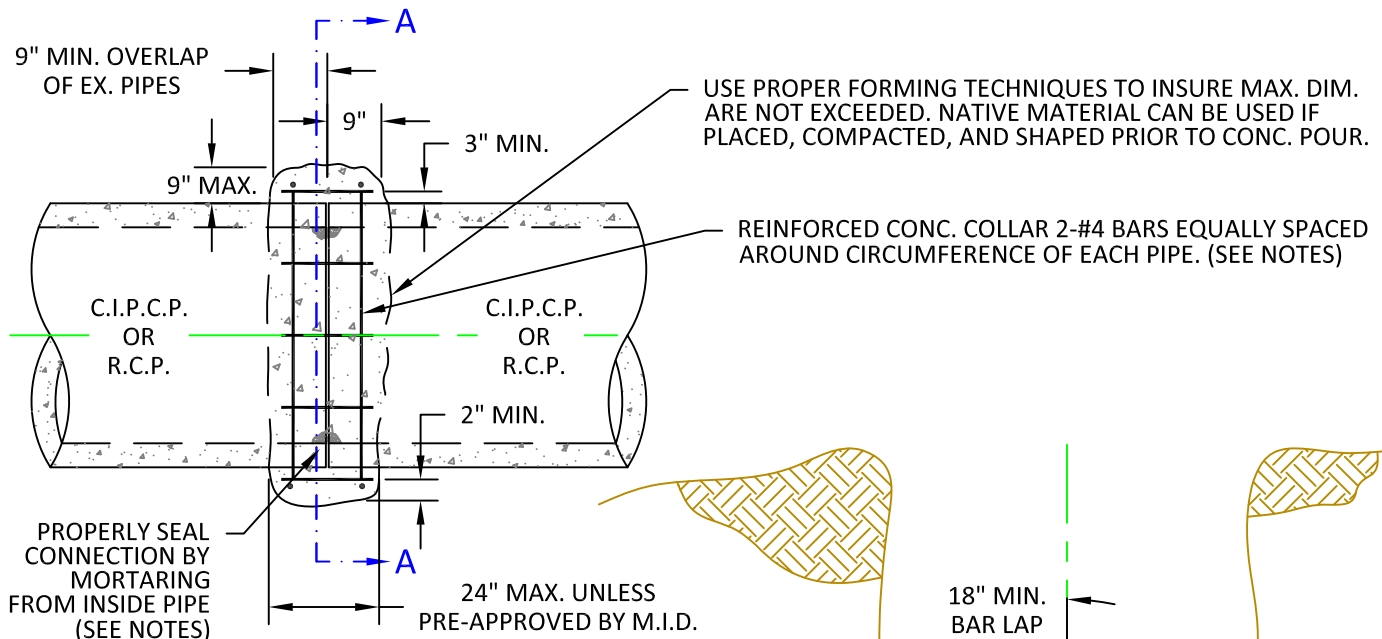

**PLAN VIEW**

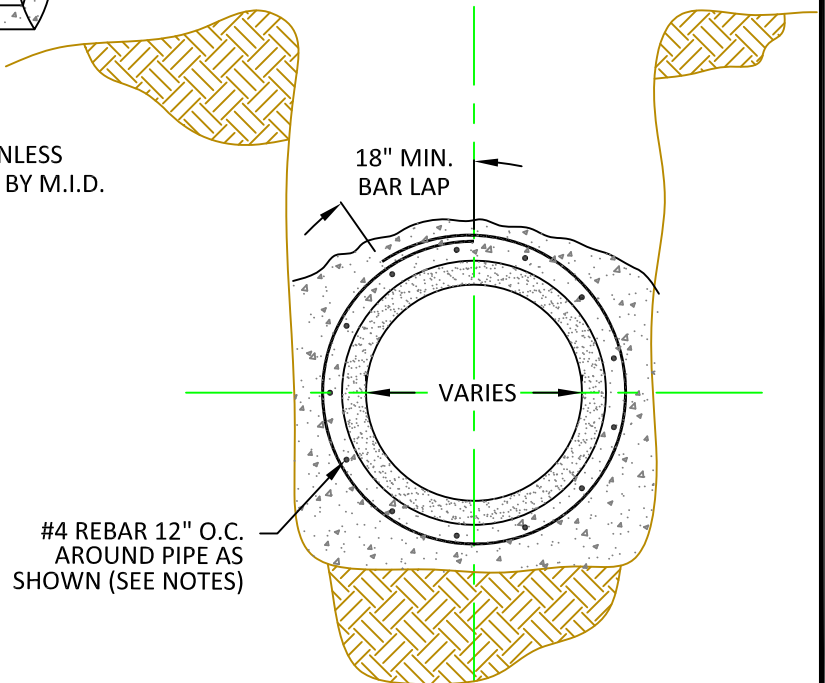

**SECTION A-A**

\*REFERENCED STANDARD(S): G 04, G 11



**CONCRETE COLLAR FOR CONCRETE PIPELINE**

DATE: JUNE 2017

STANDARD #:

C 01

SCALE: NONE

APPROVED BY:

CHAD J. TIENKEN, P.E., P.L.S.  
CIVIL ENGINEERING MANAGER

DATE: 9/7/17

**NOTES:**

1. CONCRETE STRENGTH TO BE 3,000 PSI @ 28 DAYS. NO ADMIXTURES SHALL BE INCORPORATED INTO CONCRETE MIX UNLESS PRE-APPROVED BY M.I.D. SEE M.I.D. STANDARD G 04 - CONCRETE NOTES\*.
2. ALL PIPE SHALL ENTER STRUCTURE AT OR NEAR PERPENDICULAR ANGLES TO THE WALL OF THE STRUCTURE.
3. THOROUGHLY BRUSH ALL DEBRIS AND CLEAN BOTH PIPE AND STRUCTURE AROUND THE ENTIRE CIRCUMFERENCE WITH WATER PRIOR TO PLACEMENT OF CONCRETE OR MORTAR.
4. MINIMUM #4 BARS FOR ALL COLLAR REINFORCEMENT.
5. A MINIMUM OF TWO CIRCUMFERENCE BARS REQUIRED WITH A MINIMUM 18" BAR LAP. THE BARS MUST HAVE A MINIMUM OF 3" CLEAR FROM PIPE O.D. AND 2" MINIMUM OF CONCRETE COVER.
6. HORIZONTAL BARS SHALL BE PLACED AT 12" O.C. EQUALLY SPACED AROUND THE CIRCUMFERENCE OF THE PIPE WITH A MINIMUM OF SIX (6) HORIZONTAL BARS.
7. PROPERLY SEAL CONNECTION BY MORTARING FROM INSIDE PIPELINE AFTER PERMANENT PLACEMENT OF CONCRETE COLLAR. A MINIMUM MORTARED BAND WIDTH OF 5" IS REQUIRED. USE SOFT BRISTLE BRUSH TO BLEND MORTAR AND CONCRETE TOGETHER. SEE M.I.D. STANDARD G 11 - M.I.D. MORTAR MIX NOTES\*.

REV	CHANGE	DATE	BY
1	RELEASE	06/17	LH
2	REVISED	04/22	LH
3			
4			

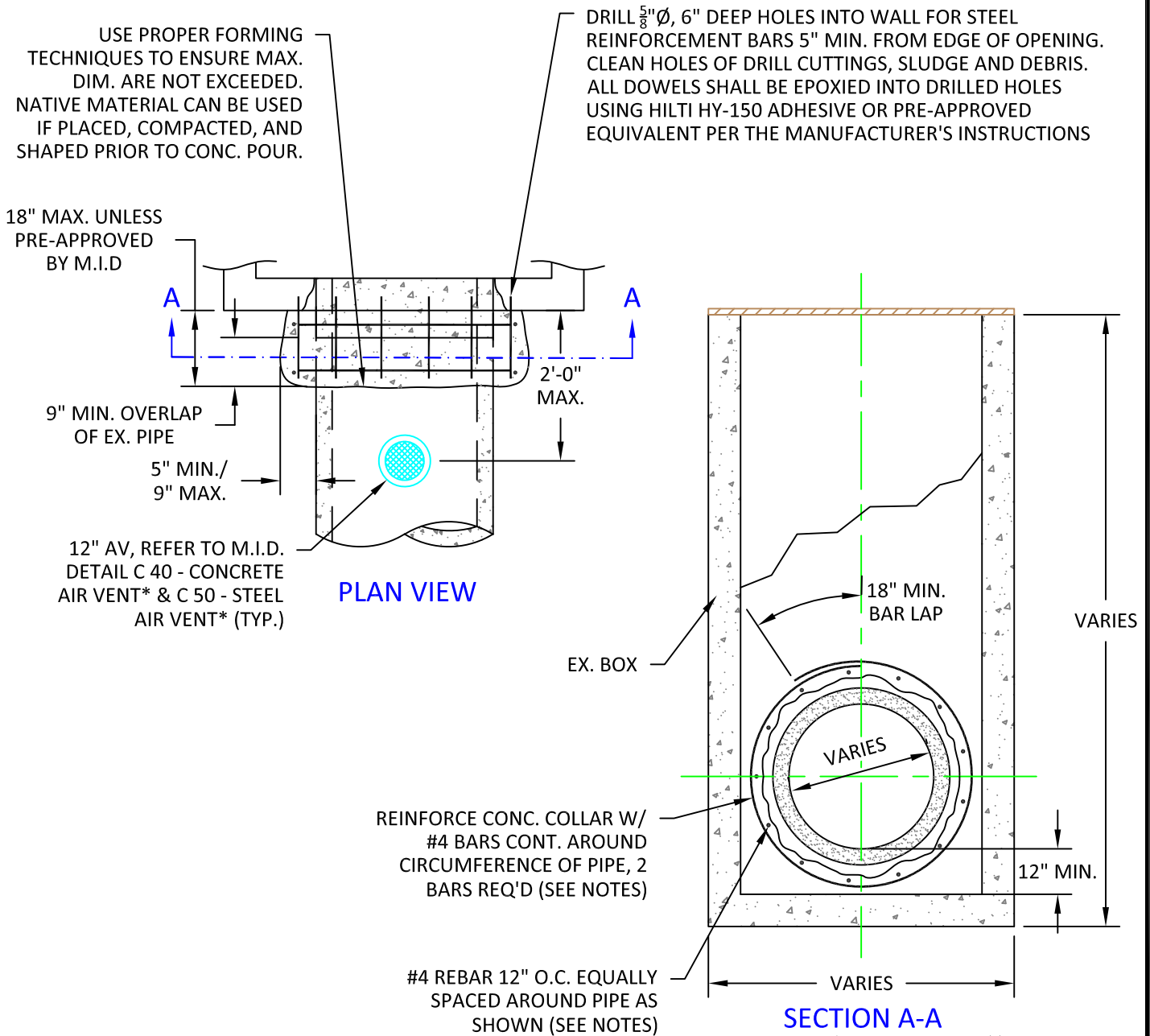

**CONCRETE PIPELINE CONNECTION TO EXISTING STRUCTURE**

DATE: JUNE 2017

STANDARD #:

C 05

SCALE: NONE

APPROVED BY:

*David B. Bakker*

DAVID B. BAKKER, P.E.  
SENIOR CIVIL ENGINEER

DATE: 4/29/22



NOTES:

1. CONCRETE STRENGTH TO BE 3,000 PSI @ 28 DAYS. NO ADMIXTURES SHALL BE INCORPORATED INTO CONCRETE MIX UNLESS PRE-APPROVED BY M.I.D. SEE M.I.D. STANDARD G 04 - CONCRETE NOTES\*.
2. ALL PIPE SHALL ENTER BOX AT OR NEAR PERPENDICULAR ANGLES TO THE BOX.
3. ALL COLD JOINTS REQUIRE 6" CENTER BULB RUBBER WATER STOP EMBEDDED IN CENTER OF WALL AT COLD JOINT LOCATION PER MANUFACTURER'S RECOMMENDATIONS. SEE M.I.D. STANDARD G 07 - NEW CONSTRUCTION JOINT\*.
4. IF TOP OF STRUCTURE IS 4 FEET OR MORE ABOVE SURROUNDING GRADE, A LADDER SHALL BE REQUIRED. IF TOP OF STRUCTURE IS 7.5 FEET OR MORE ABOVE SURROUNDING GRADE, HANDRAILING SHALL ALSO BE REQUIRED. REFER TO M.I.D. STANDARDS M 45 - STRUCTURE HANDRAILING\*, AND M 46 - STRUCTURE LADDER\*.
5. CANAL GATE TO BE WATERMAN C-10 CANAL GATE WITH GALVANIZED FRAME OR PRE-APPROVED EQUIVALENT.
6. PROPERLY SEAL ALL BOX JOINTS AND PIPES BY MORTARING FROM INSIDE OF BOX. USE SOFT BRISTLE BRUSH TO BLEND MORTAR AND CONCRETE TOGETHER. SEE M.I.D. STANDARD G 11 - M.I.D. MORTAR MIX NOTES\*.
7. WATERSTOP SURROUNDING OPENINGS SHALL BE VOLCLAY WATERSTOP-RX 102 BENTONITE CLAY STRIP OR ADEKA ULTRASEAL KBA-1510FP WATERSTOP, PLACED AROUND OUTSIDE OF PIPE IN CENTER OF WALL.

REV	CHANGE	DATE	BY
1	RELEASE	06/17	LH
2	REVISED	04/22	LH
3			
4			

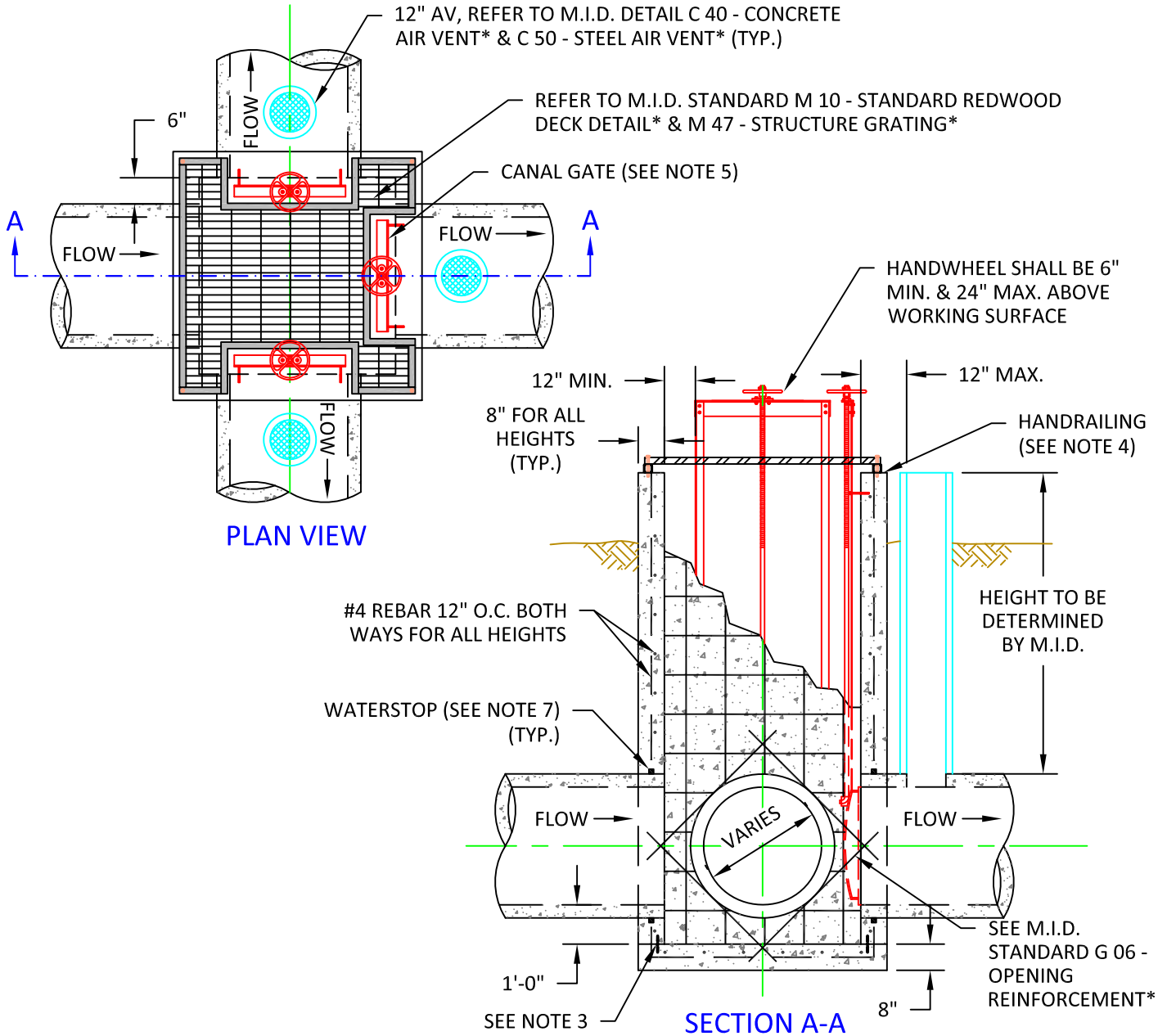

\*REFERENCED STANDARD(S): G 06, G 07, G 11, C 40, C 50, M 10, M 45, M 46, M 47



CONTROL BOX  
FOR CONCRETE PIPELINE

DATE: JUNE 2017

STANDARD #:

C 10

SCALE: NONE

APPROVED BY:

*David B. Bakker*

DAVID B. BAKKER, P.E.  
SENIOR CIVIL ENGINEER

DATE: 4/29/22

**NOTES:**

1. CONCRETE STRENGTH TO BE 3,000 PSI @ 28 DAYS. NO ADMIXTURES SHALL BE INCORPORATED INTO CONCRETE MIX UNLESS PRE-APPROVED BY M.I.D. SEE M.I.D. STANDARD G 04 - CONCRETE NOTES\*.
2. ALL PIPE SHALL ENTER BOX AT OR NEAR PERPENDICULAR ANGLES TO THE BOX.
3. PROPERLY SEAL ALL BOX JOINTS AND PIPES BY MORTARING FROM INSIDE OF BOX. USE SOFT BRISTLE BRUSH TO BLEND MORTAR AND CONCRETE TOGETHER. SEE M.I.D. STANDARD G 11 - M.I.D. MORTAR MIX NOTES\*.
4. IF TOP OF STRUCTURE IS 4 FEET OR MORE ABOVE SURROUNDING GRADE, A LADDER SHALL BE REQUIRED. IF TOP OF STRUCTURE IS 7.5 FEET OR MORE ABOVE SURROUNDING GRADE, HANDRAILING SHALL ALSO BE REQUIRED. REFER TO M.I.D. STANDARDS M 45 - STRUCTURE HANDRAILING\*, AND M 46 - STRUCTURE LADDER\*.
5. CANAL GATE TO BE WATERMAN C-10 CANAL GATE WITH GALVANIZED FRAME OR PRE-APPROVED EQUIVALENT.

REV	CHANGE	DATE	BY
1	RELEASE	06/17	LH
2	REVISED	04/22	LH
3			
4			

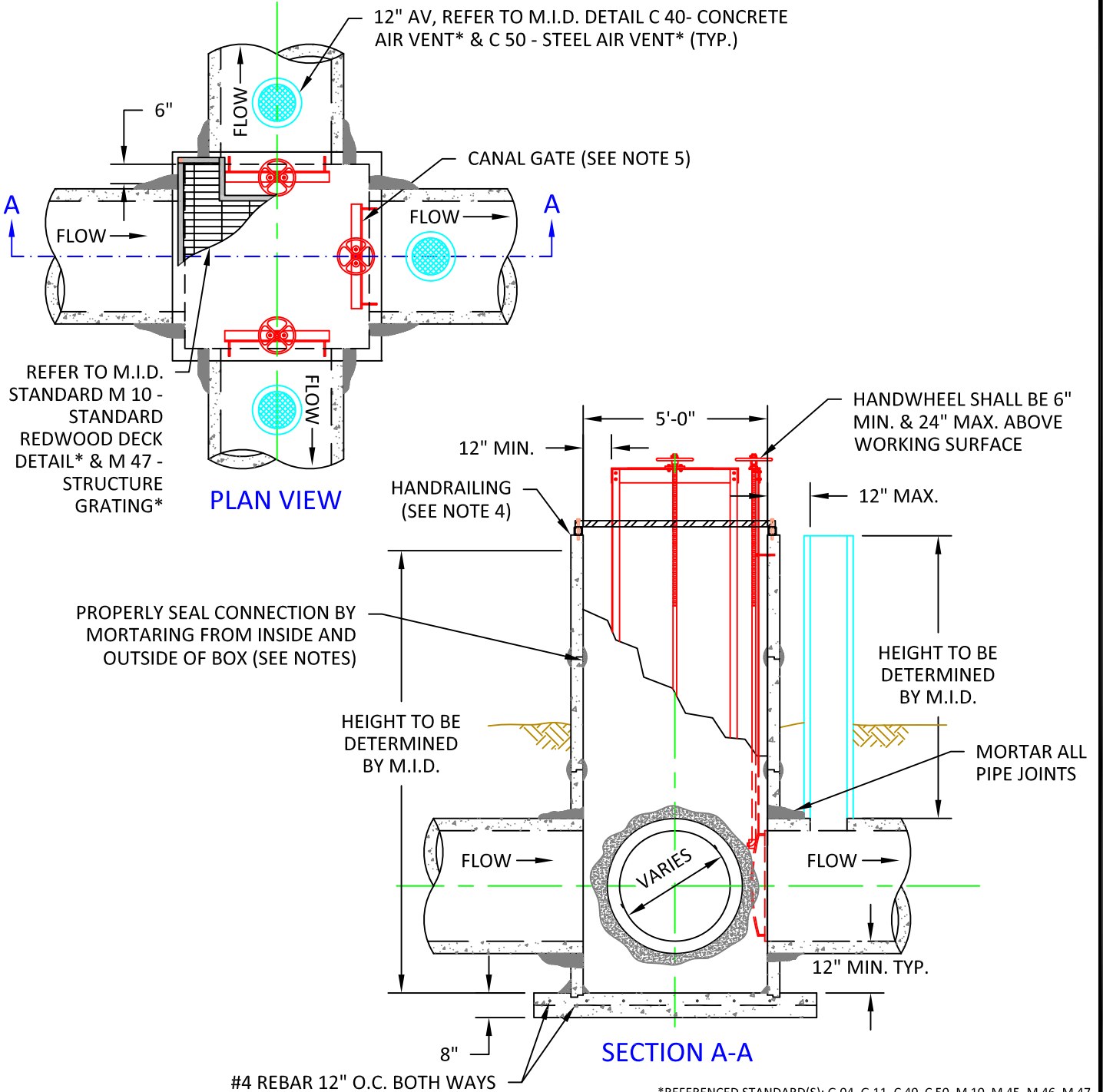

\*REFERENCED STANDARD(S): G 04, G 11, C 40, C 50, M 10, M 45, M 46, M 47



**PRECAST CONTROL BOX FOR CONCRETE PIPELINE**

DATE: JUNE 2017

STANDARD #:

C 11

SCALE: NONE

APPROVED BY:

*David B. Bakker*

DAVID B. BAKKER, P.E.  
SENIOR CIVIL ENGINEER

DATE: 4/29/22

**NOTES:**

1. CONCRETE STRENGTH TO BE 3,000 PSI @ 28 DAYS. NO ADMIXTURES SHALL BE INCORPORATED INTO CONCRETE MIX UNLESS PRE-APPROVED BY M.I.D. SEE M.I.D. STANDARD G 04 - CONCRETE NOTES\*.
2. ALL PIPE SHALL ENTER BOX AT OR NEAR PERPENDICULAR ANGLES TO THE BOX.
3. ALL COLD JOINTS REQUIRE 6" CENTER BULB RUBBER WATER STOP EMBEDDED IN CENTER OF WALL AT COLD JOINT LOCATION PER MANUFACTURER'S RECOMMENDATIONS. SEE M.I.D. STANDARD G 07 - NEW CONSTRUCTION JOINT\*.
4. WHEN AIR VENT IS WITHIN 5' OF TRAVELED WAY, AIR VENT SHALL BE BREAK AWAY TYPE. SEE DETAIL "A".
5. WATERSTOP SURROUNDING OPENINGS SHALL BE VOLCLAY WATERSTOP-RX 102 BENTONITE CLAY STRIP OR ADEKA ULTRASEAL KBA-1510FP WATERSTOP, PLACED AROUND OUTSIDE OF PIPE IN CENTER OF WALL.
6. PROPERLY SEAL ALL BOX JOINTS AND PIPES BY MORTARING FROM INSIDE OF BOX. USE SOFT BRISTLE BRUSH TO BLEND MORTAR AND CONCRETE TOGETHER. SEE M.I.D. STANDARD G 11 - M.I.D. MORTAR MIX NOTES\*.

REV	CHANGE	DATE	BY
1	RELEASE	06/17	LH
2	REVISED	04/22	LH
3			
4			

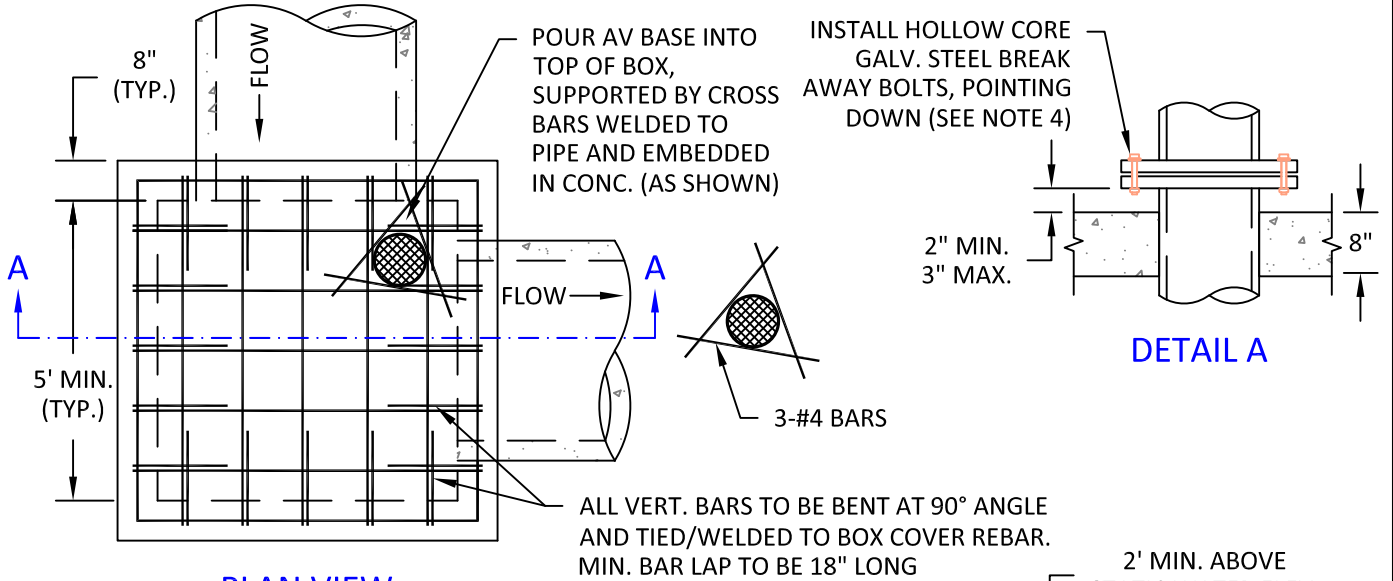

**PLAN VIEW**

**DETAIL A**

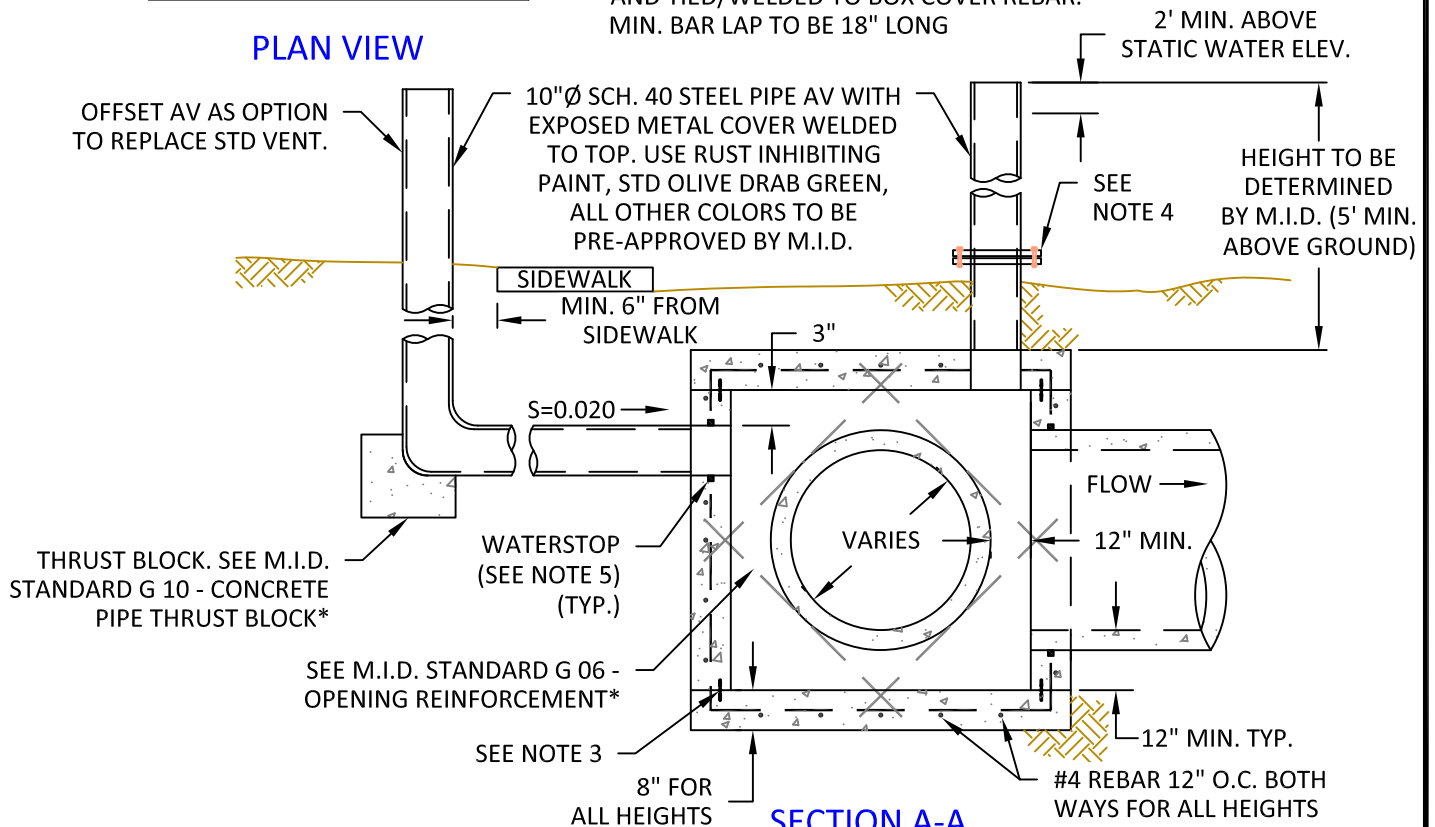

**SECTION A-A**

\*REFERENCED STANDARD(S): G 04, G 06, G 07, G 10, G 11



**PRESSURE BOX FOR CONCRETE PIPELINE**

DATE: JUNE 2017  
SCALE: NONE

STANDARD #: C 15

APPROVED BY:

*David B. Bakker*  
DAVID B. BAKKER, P.E.  
SENIOR CIVIL ENGINEER

DATE: 4/29/22

**NOTES:**

1. CONCRETE STRENGTH TO BE 3,000 PSI @ 28 DAYS. NO ADMIXTURES SHALL BE INCORPORATED INTO CONCRETE MIX UNLESS PRE-APPROVED BY M.I.D. SEE M.I.D. STANDARD G 04 - CONCRETE NOTES\*.
2. ALL PIPE SHALL ENTER BOX AT OR NEAR PERPENDICULAR ANGLES TO THE BOX.
3. ALL COLD JOINTS REQUIRE 6" CENTER BULB RUBBER WATER STOP EMBEDDED IN CENTER OF WALL AT COLD JOINT LOCATION PER MANUFACTURER'S RECOMMENDATIONS. SEE M.I.D. STANDARD G 07 - NEW CONSTRUCTION JOINT\*.
4. STANDARD 24 INCH DIAMETER HEAVY DUTY PRESSURE TYPE MANHOLE FRAME AND COVER WITH MINIMUM 4-1/2 INCH SS BOLTS - SOUTH BAY FOUNDRY A1900-R3B, D&L SUPPLY COMPANY A-1094 OR PRE-APPROVED EQUIVALENT. ALL MANHOLES TO BE INSTALLED WITH 5/16" SQUARE NEOPRENE GASKET AND BOLT GASKETS AND "M.I.D." CAST IN COVER.
5. WHEN AIR VENT IS WITHIN 5' OF TRAVELED WAY, AIR VENT SHALL BE BREAK AWAY TYPE. SEE DETAIL "A".
6. PROPERLY SEAL ALL BOX JOINTS AND PIPES BY MORTARING FROM INSIDE OF BOX. USE SOFT BRISTLE BRUSH TO BLEND MORTAR AND CONCRETE TOGETHER. SEE M.I.D. STANDARD G 11 - M.I.D. MORTAR MIX NOTES\*.
7. WATERSTOP SURROUNDING OPENINGS SHALL BE VOLCLAY WATERSTOP-RX 102 BENTONITE CLAY STRIP OR ADEKA ULTRASEAL KBA-1510FP WATERSTOP, PLACED AROUND OUTSIDE OF PIPE IN CENTER OF WALL.

REV	CHANGE	DATE	BY
1	RELEASE	06/17	LH
2	REVISED	04/22	LH
3			
4			

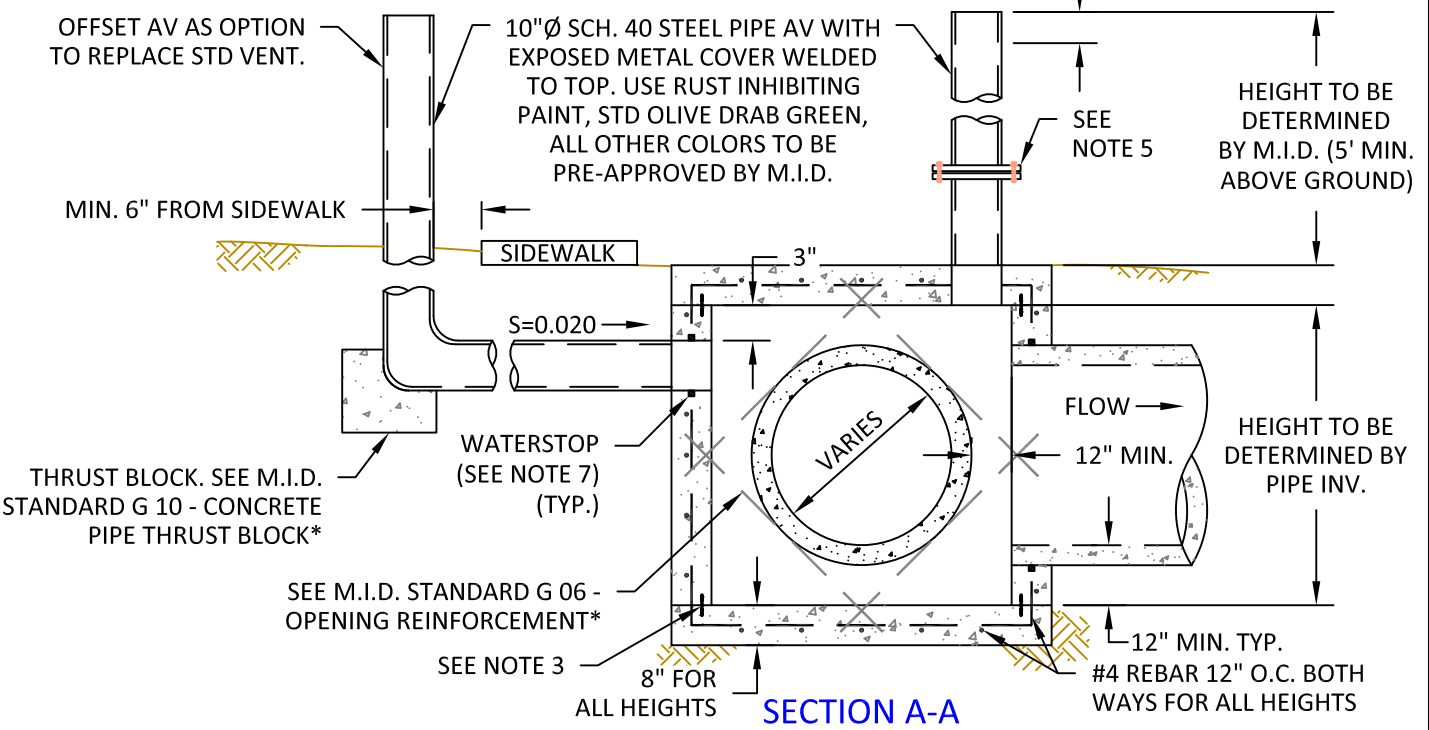
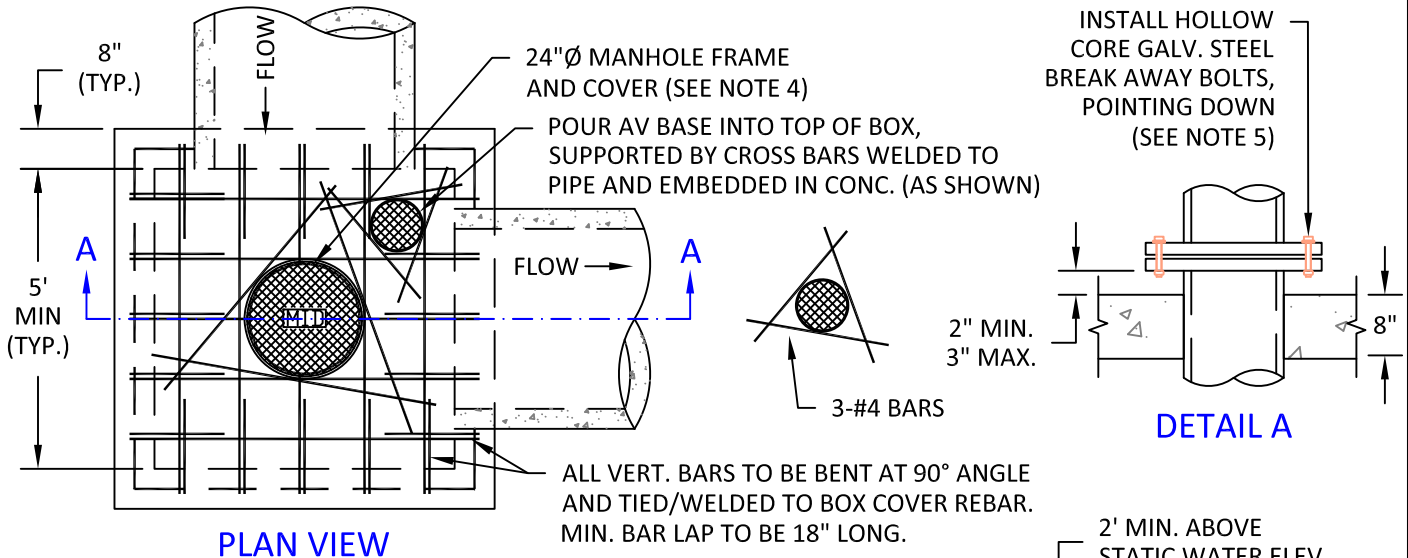

\*REFERENCED STANDARD(S): G 04, G 06, G 07, G 10, G 11



**PRESSURE MANHOLE  
FOR CONCRETE PIPELINE**

DATE: JUNE 2017      STANDARD #: C 20

SCALE: NONE

APPROVED BY:

*David B. Bakker*

DAVID B. BAKKER, P.E.  
SENIOR CIVIL ENGINEER

DATE: 4/29/22

**NOTES:**

1. CONCRETE STRENGTH TO BE 3,000 PSI @ 28 DAYS. NO ADMIXTURES SHALL BE INCORPORATED INTO CONCRETE MIX UNLESS PRE-APPROVED BY M.I.D. SEE M.I.D. STANDARD G 04 - CONCRETE NOTES\*.
2. ALL PIPE SHALL ENTER BOX AT OR NEAR PERPENDICULAR ANGLES TO THE BOX.
3. ALL COLD JOINTS REQUIRE 6" CENTER BULB RUBBER WATER STOP EMBEDDED IN CENTER OF WALL AT COLD JOINT LOCATION PER MANUFACTURER'S RECOMMENDATIONS. SEE M.I.D. STANDARD G 07 - NEW CONSTRUCTION JOINT\*.
4. PROPERLY SEAL ALL BOX JOINTS AND PIPES BY MORTARING FROM INSIDE OF BOX. USE SOFT BRISTLE BRUSH TO BLEND MORTAR AND CONCRETE TOGETHER. SEE M.I.D. STANDARD G 11 - M.I.D. MORTAR MIX NOTES\*.
5. WATERSTOP SURROUNDING OPENINGS SHALL BE VOLCLAY WATERSTOP-RX 102 BENTONITE CLAY STRIP OR ADEKA ULTRASEAL KBA-1510FP WATERSTOP, PLACED AROUND OUTSIDE OF PIPE IN CENTER OF WALL.

REV	CHANGE	DATE	BY
1	RELEASE	06/17	LH
2			
3			
4			

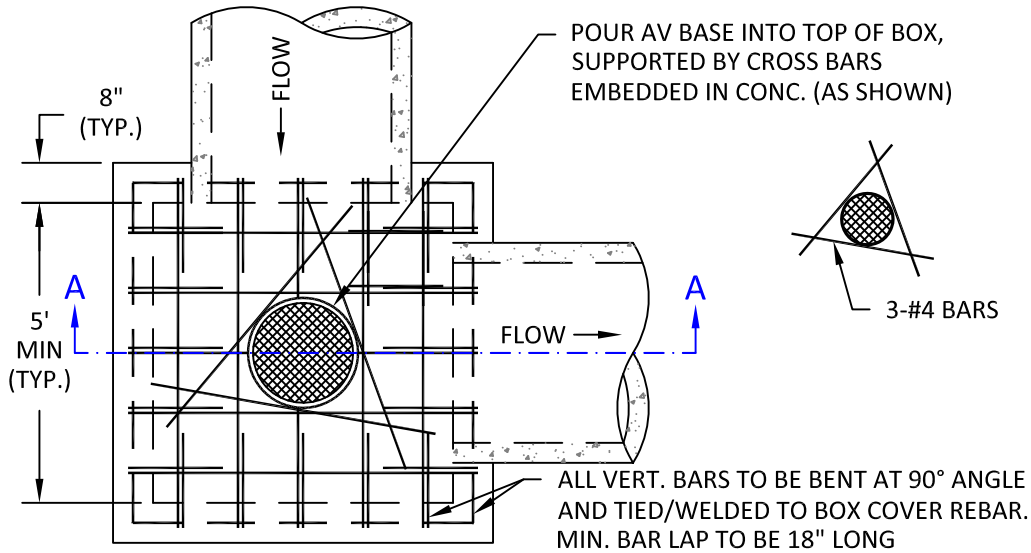

**PLAN VIEW**

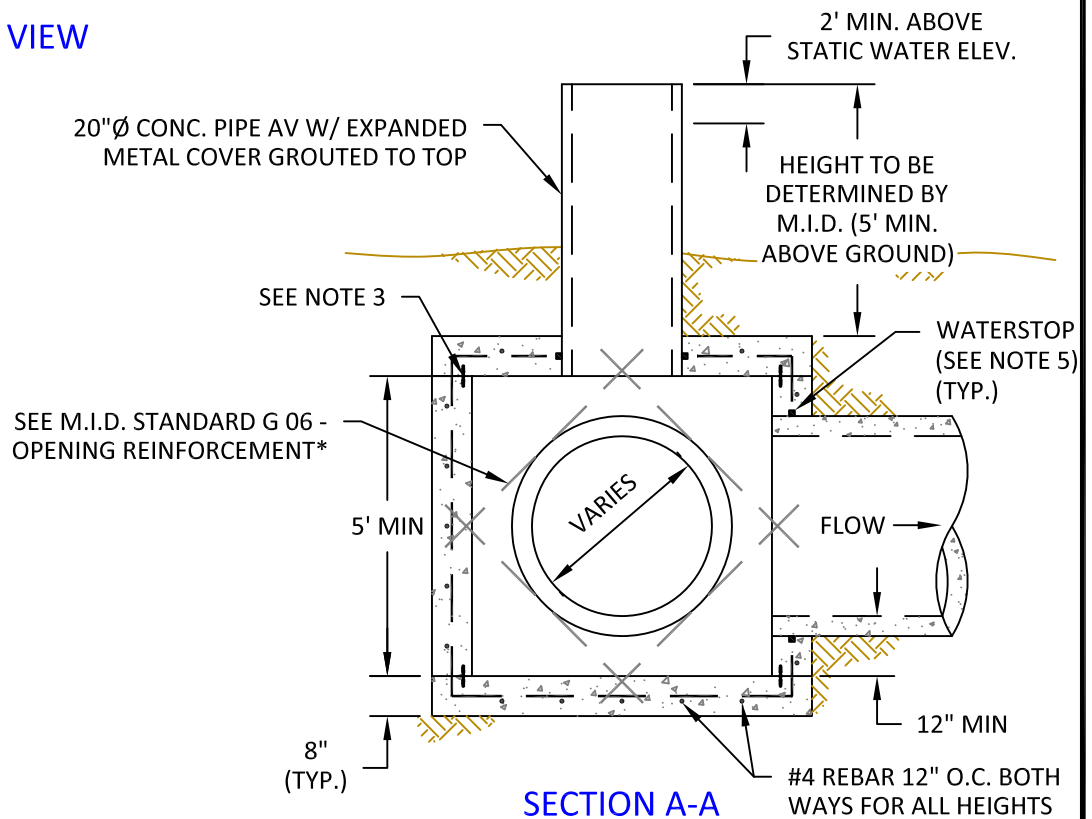

**SECTION A-A**

\*REFERENCED STANDARD(S): G 04, G 06, G 07, G 11



**PRESSURE BOX WITH 20" VENT FOR CONCRETE PIPELINE**

DATE: JUNE 2017

STANDARD #:

C 25

SCALE: NONE

APPROVED BY:

CHAD J. TIENKEN, P.E., P.L.S.  
CIVIL ENGINEERING MANAGER

DATE: 9/7/17

**NOTES:**

1. CONCRETE STRENGTH TO BE 3,000 PSI @ 28 DAYS. NO ADMIXTURES SHALL BE INCORPORATED INTO CONCRETE MIX UNLESS PRE-APPROVED BY M.I.D. SEE M.I.D. STANDARD G 04 - CONCRETE NOTES\*.
2. ALL PIPE SHALL ENTER BOX AT OR NEAR PERPENDICULAR ANGLES TO THE BOX.
3. ALL COLD JOINTS REQUIRE 6" CENTER BULB RUBBER WATER STOP EMBEDDED IN CENTER OF WALL AT COLD JOINT LOCATION PER MANUFACTURER'S RECOMMENDATIONS. SEE M.I.D. STANDARD G 07 - NEW CONSTRUCTION JOINT\*.
4. IF TOP OF STRUCTURE IS 4 FEET OR MORE ABOVE SURROUNDING GRADE, A LADDER SHALL BE REQUIRED. IF TOP OF STRUCTURE IS 7.5 FEET OR MORE ABOVE SURROUNDING GRADE, HANDRAILING SHALL ALSO BE REQUIRED. REFER TO M.I.D. STANDARDS M 45 - STRUCTURE HANDRAILING\* AND M 46 - STRUCTURE LADDER\*.
5. CANAL GATE TO BE WATERMAN C-10 CANAL GATE WITH GALVANIZED FRAME OR PRE-APPROVED EQUIVALENT.
6. PROPERLY SEAL ALL BOX JOINTS AND PIPES BY MORTARING FROM INSIDE OF BOX. USE SOFT BRISTLE BRUSH TO BLEND MORTAR AND CONCRETE TOGETHER. SEE M.I.D. STANDARD G 11 - M.I.D. MORTAR MIX NOTES\*.
7. WATERSTOP SURROUNDING OPENINGS SHALL BE VOLCLAY WATERSTOP-RX 102 BENTONITE CLAY STRIP OR ADEKA ULTRASEAL KBA-1015FP WATERSTOP, PLACED AROUND OUTSIDE OF PIPE IN CENTER OF WALL.

REV	CHANGE	DATE	BY
1	RELEASE	06/17	LH
2	REVISED	04/22	LH
3			
4			

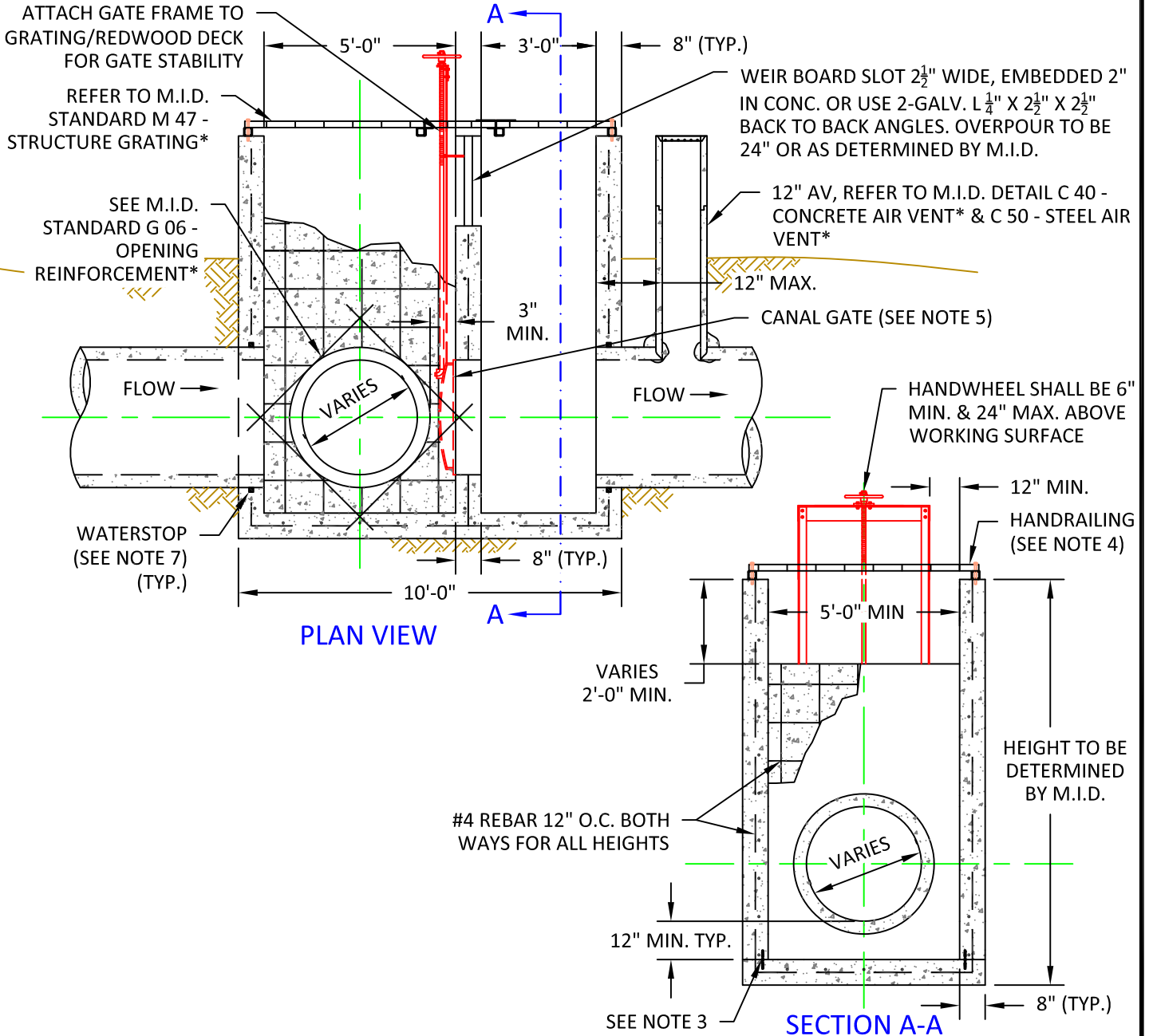

\*REFERENCED STANDARD(S): G 04, G 06, G 07, G 11, C 40, C 50, M 45, M 46, M 47



**OVERPOUR BOX FOR CONCRETE PIPELINE**

DATE: JUNE 2017

STANDARD #:

C 30

SCALE: NONE

APPROVED BY:

*David B. Bakker*

DAVID B. BAKKER, P.E.  
SENIOR CIVIL ENGINEER

DATE: 4/29/22

**NOTES:**

1. CONCRETE STRENGTH TO BE 3,000 PSI @ 28 DAYS. NO ADMIXTURES SHALL BE INCORPORATED INTO CONCRETE MIX UNLESS PRE-APPROVED BY M.I.D. SEE M.I.D. STANDARD G 04 - CONCRETE NOTES\*.
2. SAW CUT, THOROUGHLY BRUSH AWAY DEBRIS AND CLEAN EXISTING LINING PRIOR TO CONCRETE PLACEMENT.
3. VENT COVER TO BE #3 OR #4 ROUND BARS WITH MAXIMUM SPACING BETWEEN BARS OF 2 INCHES AND WELDED TO #3 OR #4 CIRCUMFERENTIAL RING OR USE LIGHTWEIGHT FOUNDRY CASTING.
4. SEE M.I.D. STANDARD G 13 - STANDARD CANAL GATE NOTES\* FOR STANDARD INSTALLATION AND CONSTRUCTION NOTES.

REV	CHANGE	DATE	BY
1	RELEASE	06/17	LH
2	REVISED	04/22	LH
3			
4			

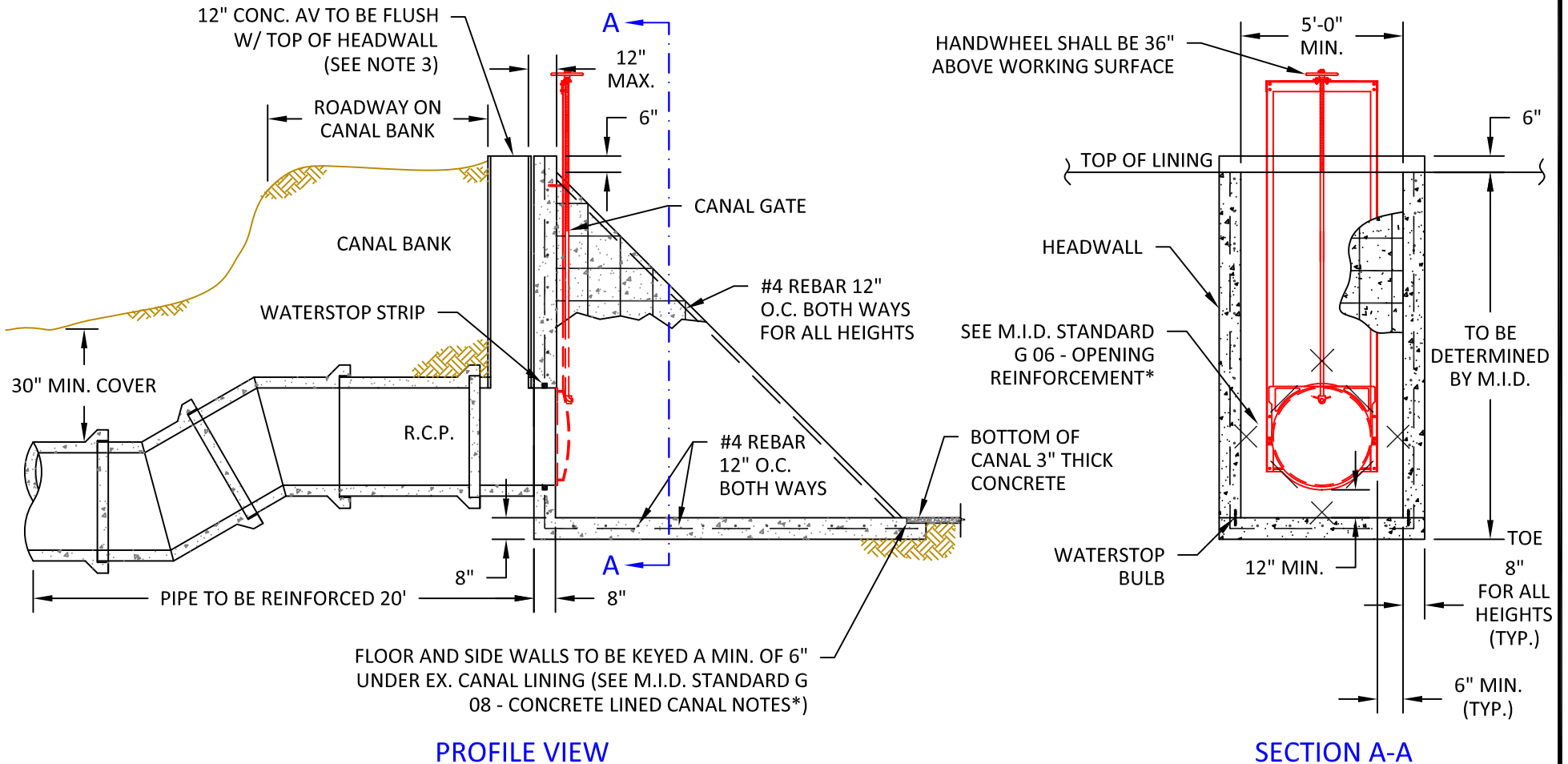

FLOOR AND SIDE WALLS TO BE KEYED A MIN. OF 6" UNDER EX. CANAL LINING (SEE M.I.D. STANDARD G 08 - CONCRETE LINED CANAL NOTES\*)

\*REFERENCED STANDARD(S): G 04, G 06, G 08, G 13



**STANDARD CANAL GATE  
FOR CONCRETE PIPELINE**

DATE: JUNE 2017  
SCALE: NONE

STANDARD #:  
C 35

APPROVED BY:

*David B. Bakker*

DAVID B. BAKKER, P.E.  
SENIOR CIVIL ENGINEER

4/29/22  
DATE

**NOTES:**

1. CONCRETE STRENGTH TO BE 3,000 PSI @ 28 DAYS. NO ADMIXTURES SHALL BE INCORPORATED INTO CONCRETE MIX UNLESS PRE-APPROVED BY M.I.D. SEE M.I.D. STANDARD G 04 - CONCRETE NOTES\*.
2. SAW CUT, THOROUGHLY BRUSH AWAY DEBRIS AND CLEAN EXISTING LINING PRIOR TO CONCRETE PLACEMENT.
3. VENT COVER TO BE #3 OR #4 ROUND BARS WITH MAXIMUM SPACING BETWEEN BARS OF 2 INCHES AND WELD TO #3 OR #4 CIRCUMFERENTIAL RING OR USE LIGHTWEIGHT FOUNDRY CASTING.
4. SEE M.I.D. STANDARD G 13 - STANDARD CANAL GATE NOTES\* FOR STANDARD INSTALLATION AND CONSTRUCTION NOTES.

REV	CHANGE	DATE	BY
1	RELEASE	06/17	LH
2	REVISED	04/22	LH
3			
4			

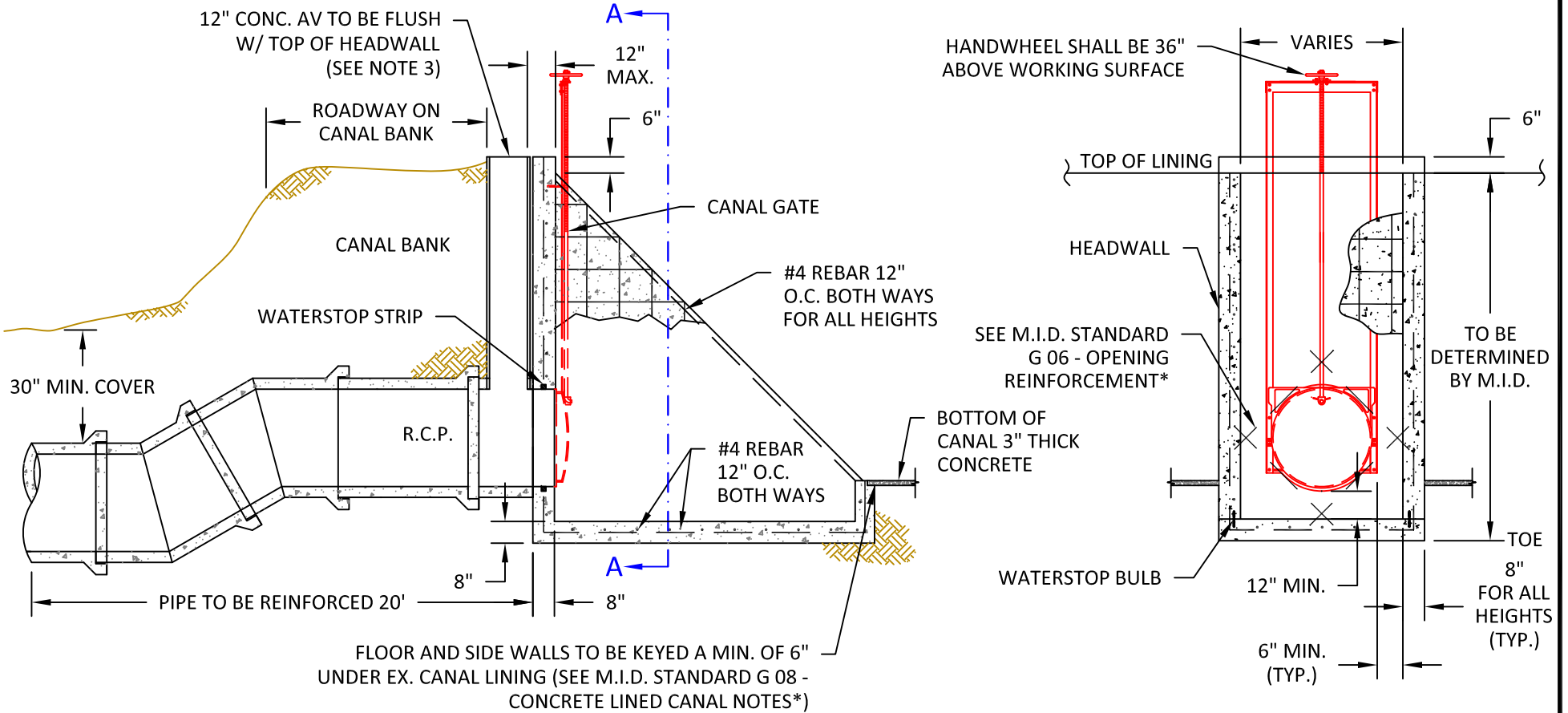

**PROFILE VIEW**

**SECTION A-A**

\*REFERENCED STANDARD(S): G 04, G 06, G 08, G 13



**STANDARD CANAL GATE  
FOR CONCRETE PIPELINE WITH SUMP**

DATE: JUNE 2017  
SCALE: NONE

STANDARD #:  
C 36

APPROVED BY:

*David B. Bakker*

DAVID B. BAKKER, P.E.  
SENIOR CIVIL ENGINEER

4/29/22  
DATE



**NOTES:**

1. CONCRETE STRENGTH TO BE 3,000 PSI @ 28 DAYS. NO ADMIXTURES SHALL BE INCORPORATED INTO CONCRETE MIX UNLESS PRE-APPROVED BY M.I.D. SEE M.I.D. STANDARD G 04 - CONCRETE NOTES\*.
2. VENT COVER TO BE #3 OR #4 ROUND BARS WITH MAXIMUM SPACING BETWEEN BARS OF 2 INCHES AND WELD TO #3 OR #4 CIRCUMFERENTIAL RING OR USE LIGHTWEIGHT FOUNDRY CASTING.
3. SEE M.I.D. STANDARD G 13 - STANDARD CANAL GATE NOTES\* FOR STANDARD INSTALLATION AND CONSTRUCTION NOTES.

REV	CHANGE	DATE	BY
1	RELEASE	06/17	LH
2	REVISED	04/22	LH
3			
4			

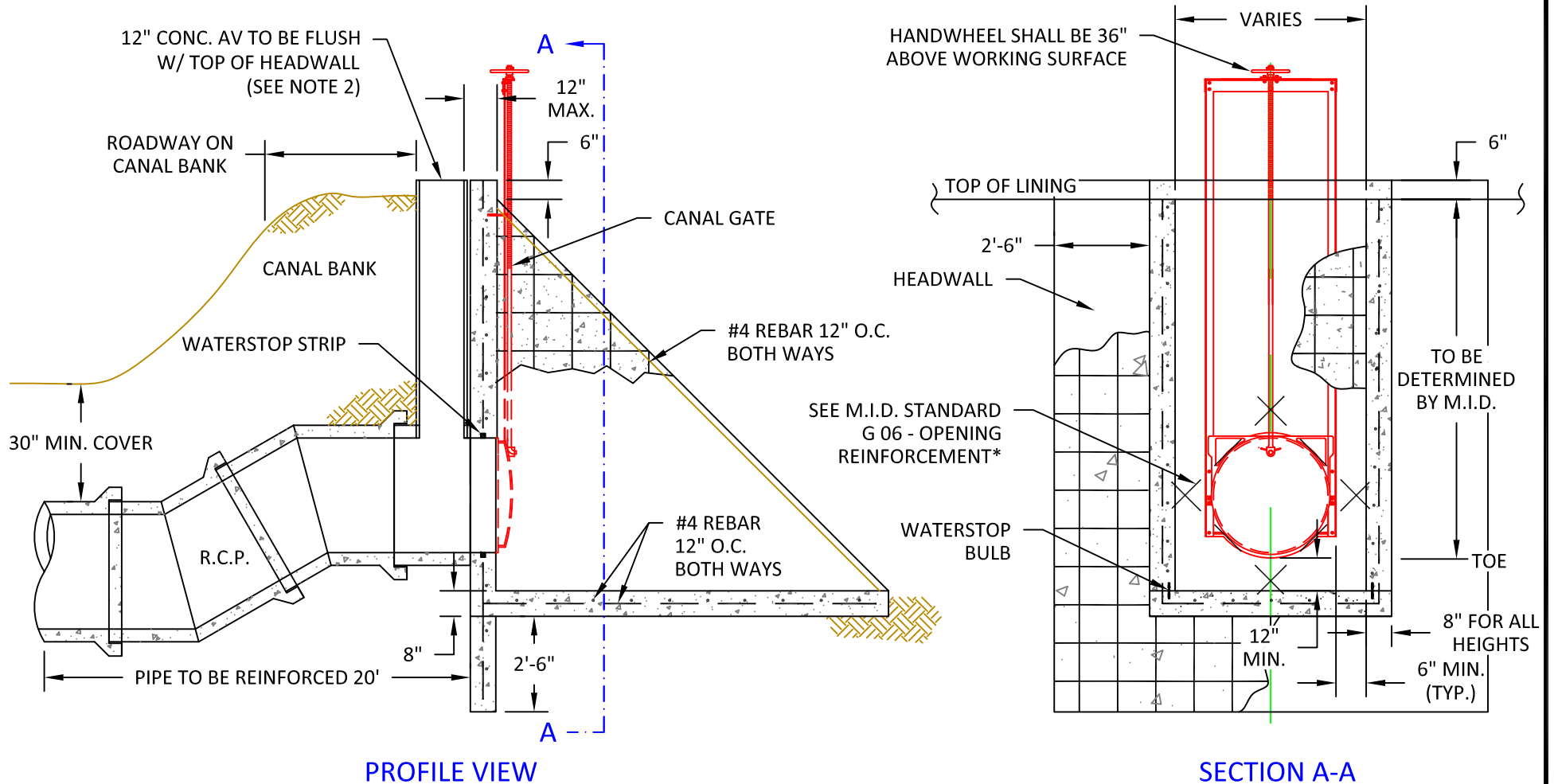

\*REFERENCE STANDARD(S): G 04, G 06, G 13



**DIRT DITCH STANDARD CANAL GATE  
FOR CONCRETE PIPELINE**

DATE: JUNE 2017  
SCALE: NONE

STANDARD #:  
C 37

APPROVED BY:

*David B. Bakker*

DAVID B. BAKKER, P.E.  
SENIOR CIVIL ENGINEER

4/29/22  
DATE

**NOTES:**

1. THOROUGHLY BRUSH ALL DEBRIS AND CLEAN EACH END OF PIPE AROUND THE ENTIRE CIRCUMFERENCE WITH WATER PRIOR TO PLACEMENT OF CONCRETE COLLAR OR MORTAR.
2. PROPERLY SEAL CONNECTION BY MORTARING FROM INSIDE PIPELINE AFTER PERMANENT PLACEMENT OF VENT PIPE. A MINIMUM MORTARED BAND WIDTH OF 5" IS REQUIRED. USE SOFT BRISTLE BRUSH TO BLEND MORTAR AND CONCRETE TOGETHER. SEE M.I.D. STANDARD G 11- M.I.D. MORTAR MIX NOTES\*.
3. IMMEDIATELY AFTER PLACEMENT OF MORTAR AND BEFORE BACKFILLING, COVER EXPOSED MORTAR WITH PLASTIC TO AVOID CRACKING.
4. VENT COVER SHALL BE EXPANDED METAL COVER, REBAR COVER OR LIGHTWEIGHT FOUNDRY COVER. REBAR COVER SHALL BE #3 OR #4 BARS WITH MAXIMUM SPACING BETWEEN BARS OF 2" AND WELD TO #3 OR #4 CIRCUMFERENTIAL RING.
5. AIR VENTS SHALL BE INSTALLED AT 500' INTERVALS, AT PIPELINE GRADE CHANGES, AT HIGH POINTS AND IMMEDIATELY DOWNSTREAM OF OUTLET STRUCTURES.

REV	CHANGE	DATE	BY
1	RELEASE	06/17	LH
2	REVISED	04/22	LH
3			
4			

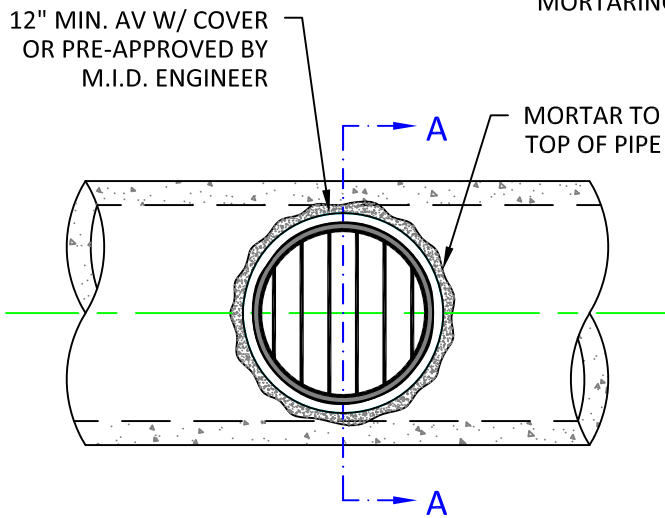
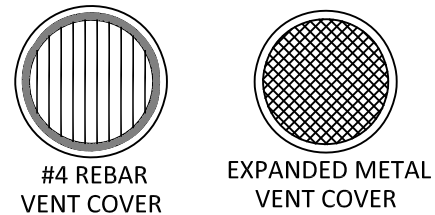

**PLAN VIEW**

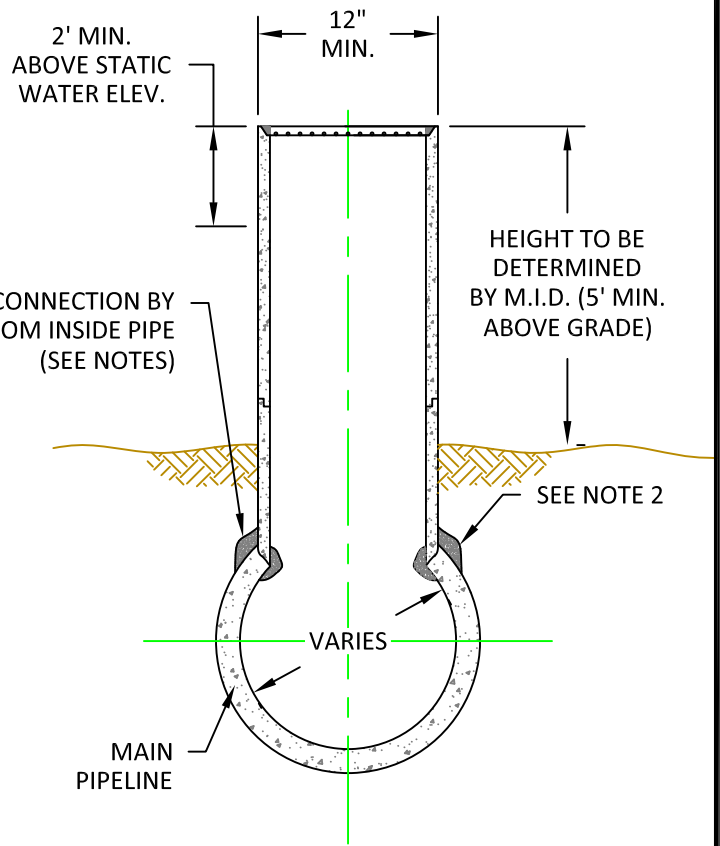

**SECTION A-A**

\*REFERENCED STANDARD(S): G 11



**CONCRETE AIR VENT FOR CONCRETE PIPELINE**

DATE: JUNE 2017

STANDARD #:

C 40

SCALE: NONE

APPROVED BY:

*David B. Bakker*

DAVID B. BAKKER, P.E.  
SENIOR CIVIL ENGINEER

DATE: 4/29/22

**NOTES:**

1. USE #3 OR #4 ROUND BARS WITH MAXIMUM SPACING BETWEEN BARS OF 2" AND WELD TO #3 OR #4 CIRCUMFERENTIAL RING OR USE LIGHTWEIGHT FOUNDRY CASTING.
2. WELD END OF BARS SECURELY TO #3 OR #4 ROUND BAR RING.
3. VENT INSTALLED WITH BELL END AT TOP.
4. COVER TO FIT INTO BELL AND THOROUGHLY GROUT AROUND ENTIRE CIRCUMFERENCE. SEE M.I.D. STANDARD G 11 - M.I.D. MORTAR MIX NOTES\*.
5. IMMEDIATELY AFTER PLACEMENT OF MORTAR COVER EXPOSED MORTAR WITH PLASTIC TO AVOID CRACKING.

REV	CHANGE	DATE	BY
1	RELEASE	06/17	LH
2			
3			
4			

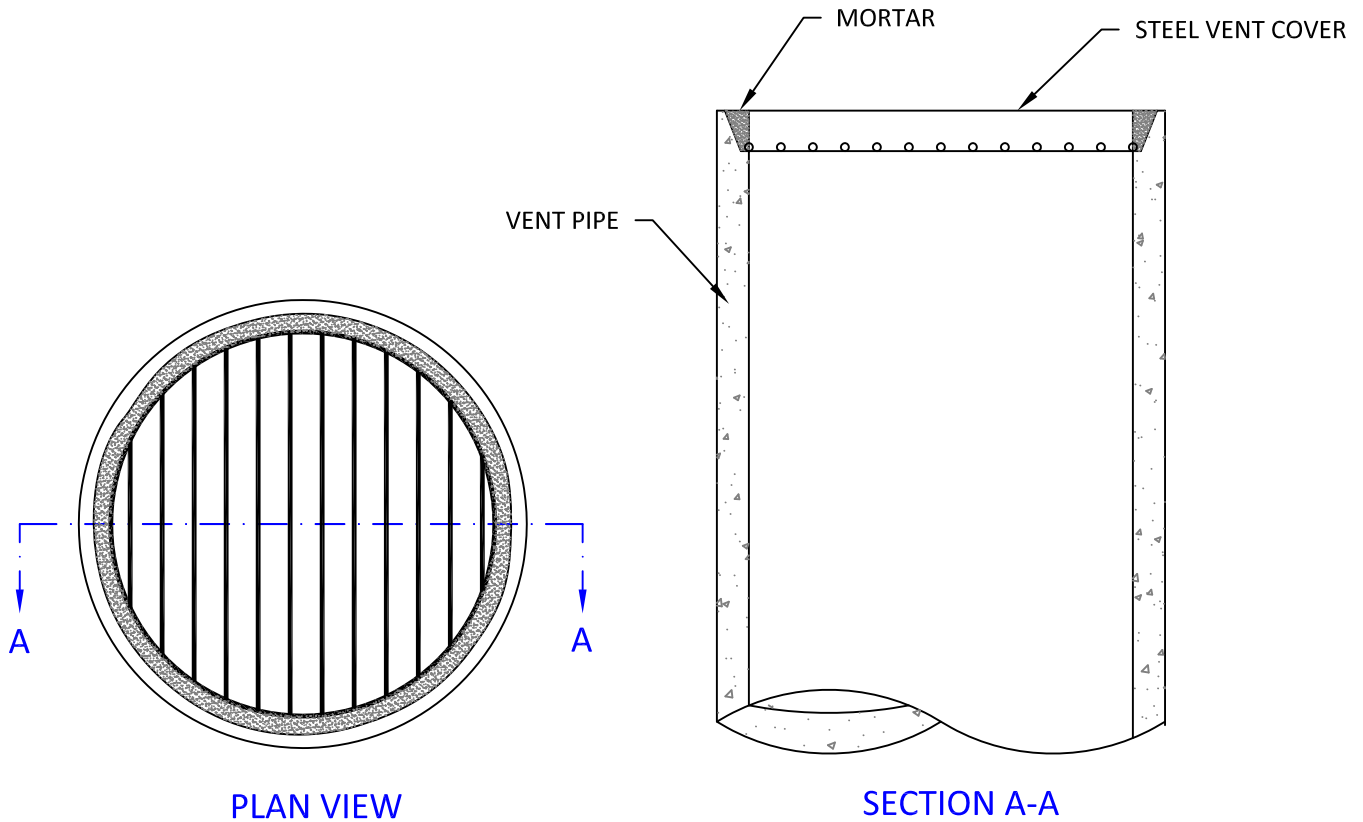

\*REFERENCED STANDARD(S): G 11



**CONCRETE AIR VENT COVER  
FOR CONCRETE PIPELINE**

DATE: JUNE 2017

STANDARD #:

C 45

SCALE: NONE

APPROVED BY:

CHAD J. TIENKEN, P.E., P.L.S.  
CIVIL ENGINEERING MANAGER

DATE: 9/7/17

**NOTES:**

1. THOROUGHLY BRUSH ALL DEBRIS AND CLEAN EACH END OF PIPE AROUND THE ENTIRE CIRCUMFERENCE WITH WATER PRIOR TO PLACEMENT OF VENT.
2. PROPERLY SEAL CONNECTION BY MORTARING FROM INSIDE PIPELINE AFTER PERMANENT PLACEMENT OF VENT PIPE. USE SOFT BRISTLE BRUSH TO BLEND MORTAR AND CONCRETE TOGETHER. USE M.I.D. STANDARD G 11- M.I.D. MORTAR MIX NOTES\*.
3. IMMEDIATELY AFTER PLACEMENT OF MORTAR AND BEFORE BACK FILLING, COVER EXPOSED MORTAR WITH PLASTIC TO AVOID CRACKING.
4. AIR VENTS SHALL BE INSTALLED AT 500' INTERVALS, AT PIPELINE GRADE CHANGES, AT HIGH POINTS AND IMMEDIATELY DOWNSTREAM OF INLET STRUCTURES.

REV	CHANGE	DATE	BY
1	RELEASE	06/17	LH
2			
3			
4			

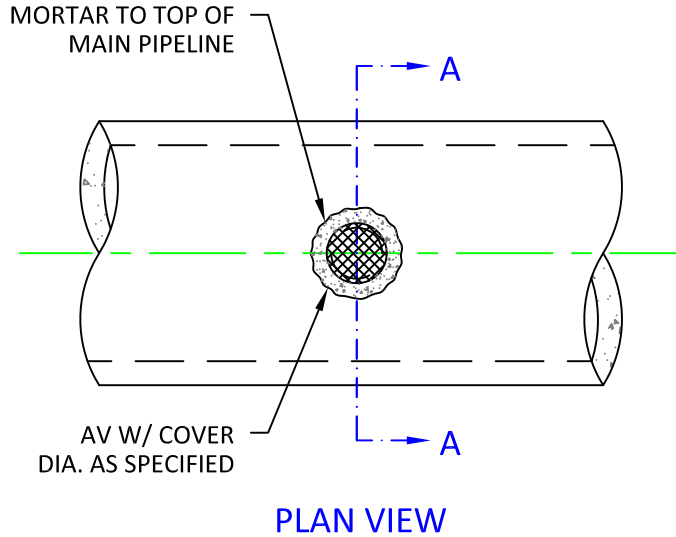

12"Ø SCH. 40 STEEL PIPE W/ EXPANDED METAL COVER WELDED TO STEEL PIPE. USE RUST INHIBITING PAINT, STD OLIVE DRAB GREEN, ALL OTHER COLORS TO BE PRE-APPROVED BY M.I.D.

POUR AV BASE INTO TOP, SUPPORTED BY CROSS BARS WELDED TO PIPE AND EMBEDDED IN CONC. (AS SHOWN)

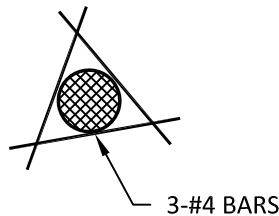

PROPERLY SEAL CONNECTION BY MORTARING FORM INSIDE PIPE (SEE NOTES)

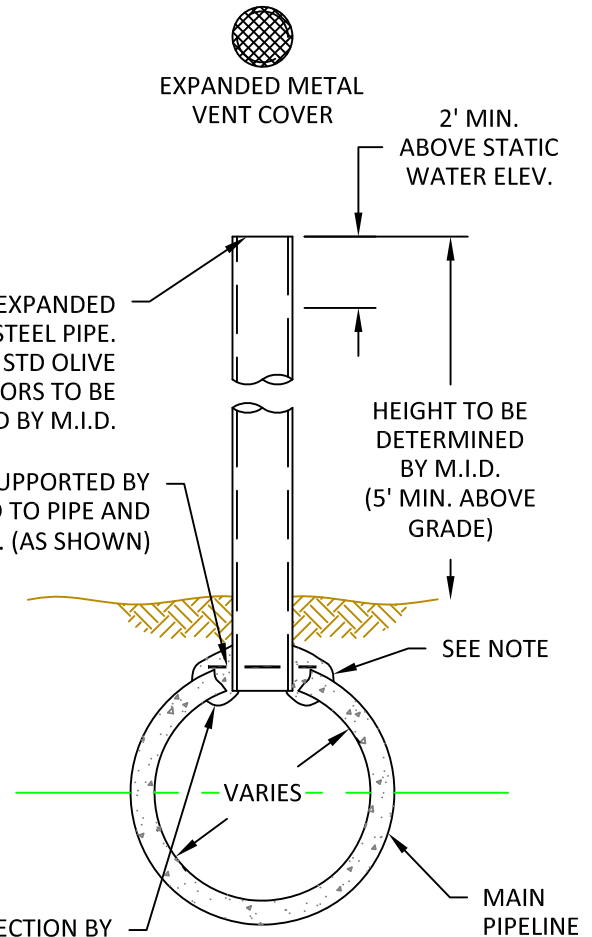

**SECTION A-A**

\*REFERENCED STANDARD(S): G 11



**STEEL AIR VENT FOR CONCRETE PIPELINE**

DATE: JUNE 2017

STANDARD #:

C 50

SCALE: NONE

APPROVED BY:

CHAD J. TIENKEN, P.E., P.L.S.  
CIVIL ENGINEERING MANAGER

DATE: 9/7/17

**NOTES:**

1. CONCRETE STRENGTH TO BE 3,000 PSI @ 28 DAYS. NO ADMIXTURES SHALL BE INCORPORATED INTO CONCRETE MIX UNLESS PRE-APPROVED BY M.I.D. SEE M.I.D. STANDARD G 04 - CONCRETE NOTES\*.
2. THOROUGHLY BRUSH ALL DEBRIS AND CLEAN EACH END OF PIPE AROUND THE ENTIRE CIRCUMFERENCE WITH WATER PRIOR TO PLACEMENT OF CONCRETE OR MORTAR.
3. PROPERLY SEAL CONNECTION BY MORTARING FROM INSIDE PIPELINE AFTER PERMANENT PLACEMENT OF PIPELINE PLUG. A MINIMUM MORTARED BAND WIDTH OF 5" IS REQUIRED. USE SOFT BRISTLE BRUSH TO BLEND MORTAR AND CONCRETE TOGETHER. SEE M.I.D. STANDARD G 11 - M.I.D. MORTAR MIX NOTES\*.
4. ALL PIPELINES MUST BE PLUGGED USING FORMWORK OR PRECAST PLUGS (NO SUBSTITUTIONS).

REV	CHANGE	DATE	BY
1	RELEASE	06/17	LH
2			
3			
4			

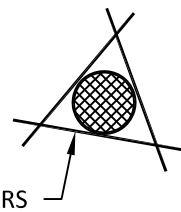
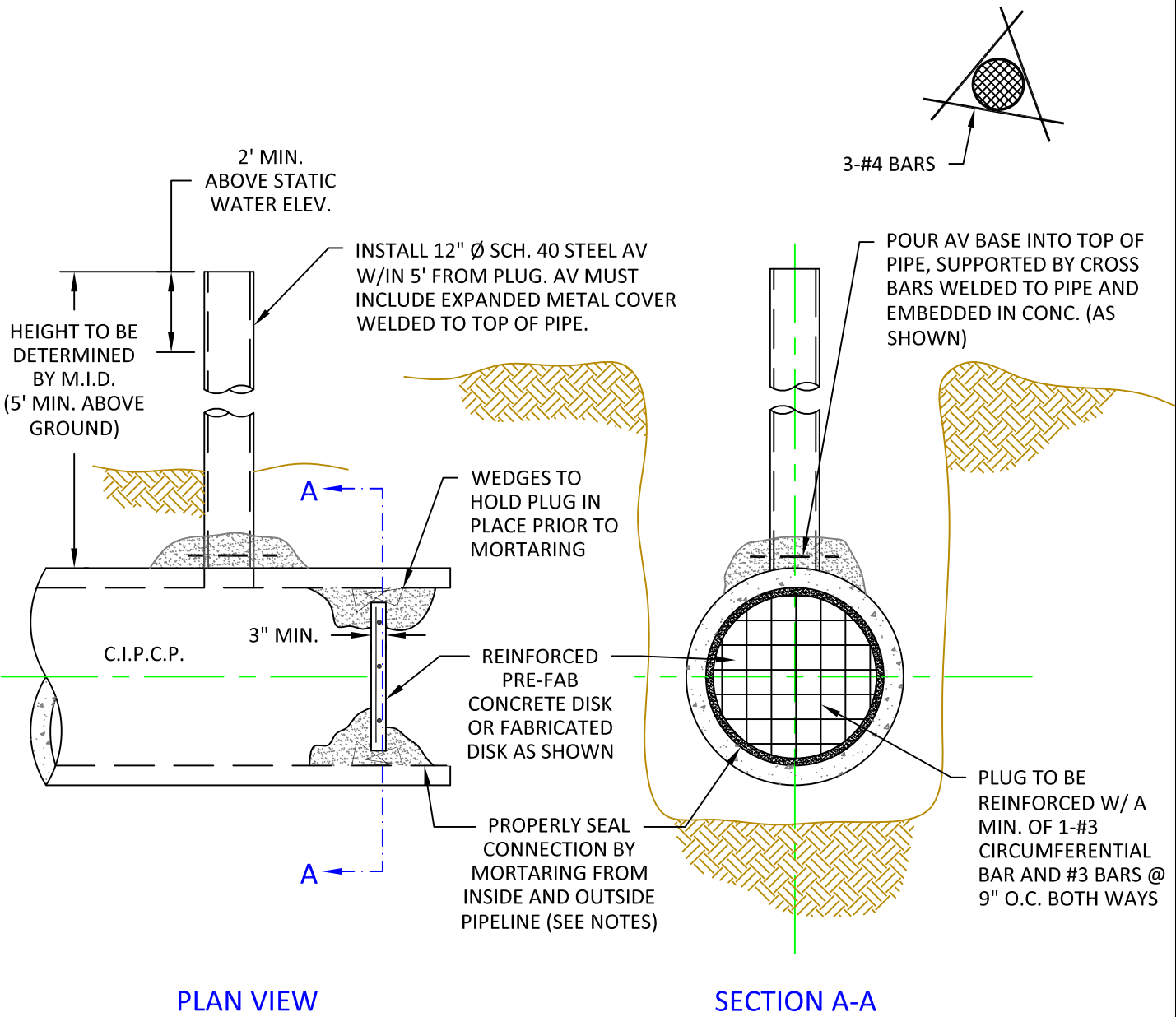

\*REFERENCED STANDARD(S): G 04, G 11



**CONCRETE PLUG  
FOR CONCRETE PIPELINE**

DATE: JUNE 2017      STANDARD #: C 55

SCALE: NONE

APPROVED BY: *Chad J. Tienken*

CHAD J. TIENKEN, P.E., P.L.S.  
CIVIL ENGINEERING MANAGER

DATE: 9/7/17

NOTES:

1. CONCRETE STRENGTH TO BE 3,000 P.S.I. @ 28 DAYS. NO ADMIXTURES SHALL BE INCORPORATED INTO CONCRETE MIX UNLESS PRE-APPROVED BY M.I.D. SEE M.I.D. STANDARD G 04 - CONCRETE NOTES\*.
2. ALL PIPE SHALL ENTER BOX AT OR NEAR PERPENDICULAR ANGLES TO THE BOX.
3. ALL COLD JOINTS REQUIRE 6" CENTER BULB RUBBER WATER STOP EMBEDDED IN CENTER OF WALL AT COLD JOINT LOCATION PER MANUFACTURER'S RECOMMENDATIONS. SEE M.I.D. STANDARD G 07 - NEW CONSTRUCTION JOINT\*.
4. GRATE REQUIRED ONLY FOR INLET STRUCTURE.
5. PROPERLY SEAL ALL BOX JOINTS AND PIPES BY MORTARING FROM INSIDE OF BOX. USE SOFT BRISTLE BRUSH TO BLEND MORTAR AND CONCRETE TOGETHER. SEE M.I.D. STANDARD G 11 - M.I.D. MORTAR MIX NOTES\*.
6. WATERSTOP SURROUNDING OPENINGS SHALL BE VOLCLAY WATERSTOP-RX 102 BENTONITE CLAY STRIP OR ADEKA ULTRASEAL KBA-1510FP WATERSTOP, PLACED AROUND OUTSIDE OF PIPE IN CENTER OF WALL.

REV	CHANGE	DATE	BY
1	RELEASE	06/17	LH
2	REVISED	04/22	LH
3			
4			

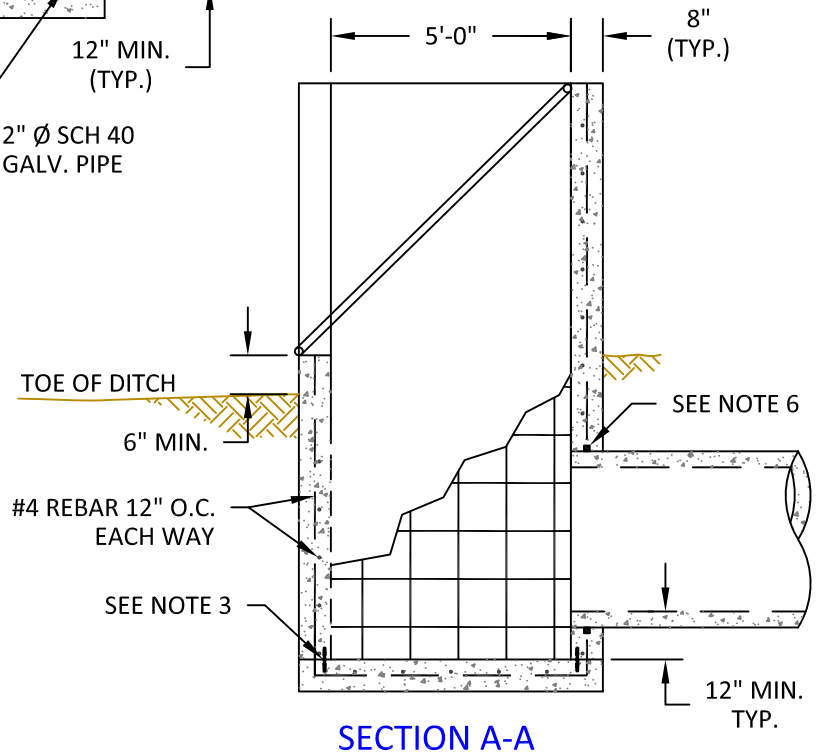
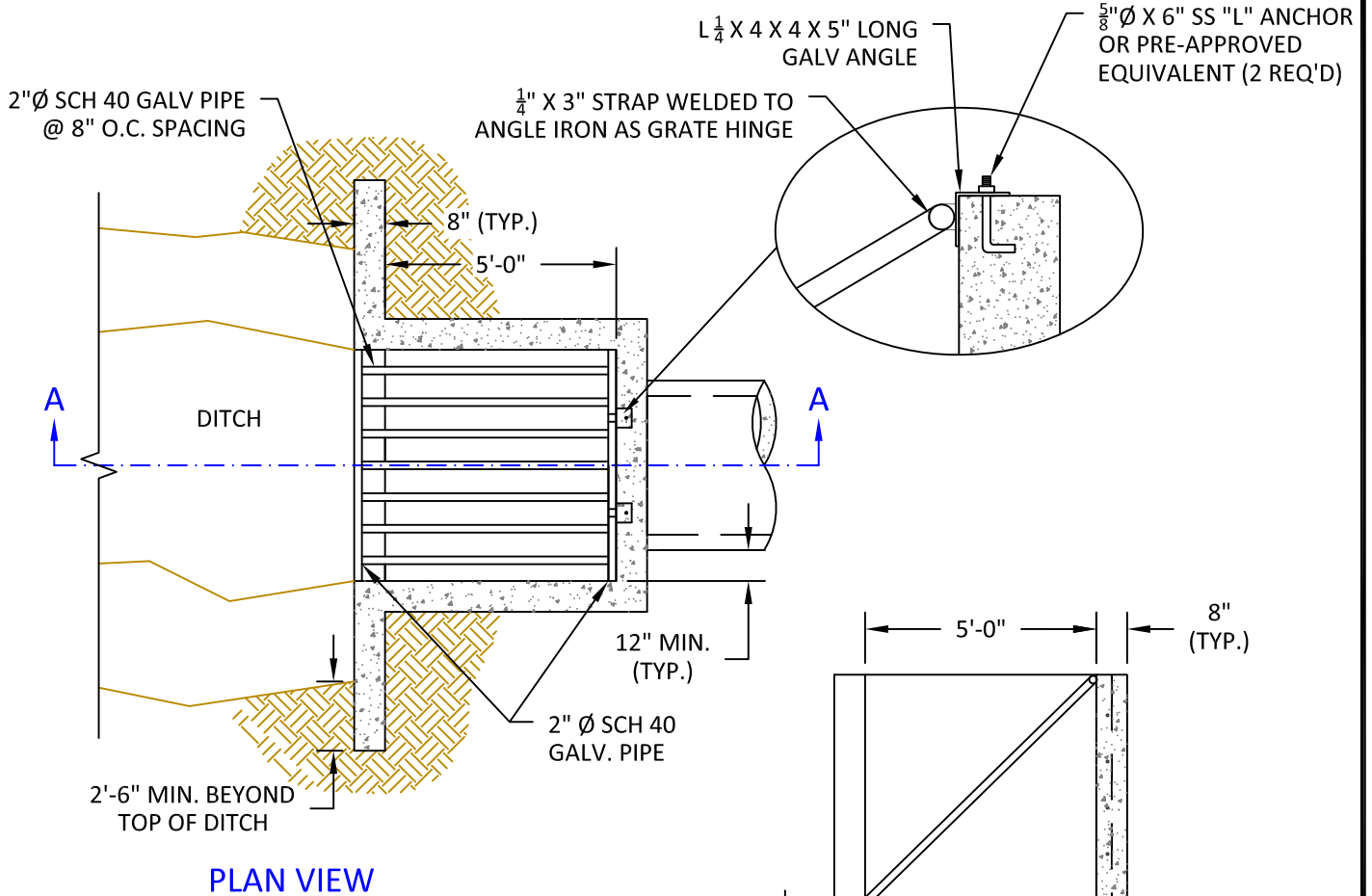

\*REFERENCED STANDARD(S): G 04, G 07, G 11



INLET / OUTLET BOX STRUCTURE FOR CONCRETE PIPELINE

DATE: JUNE 2017

STANDARD #:

C 60

SCALE: NONE

APPROVED BY:

*David B. Bakker*

DAVID B. BAKKER, P.E.  
SENIOR CIVIL ENGINEER

DATE: 4/29/22

**NOTES:**

1. CONCRETE STRENGTH TO BE 3,000 PSI @ 28 DAYS. NO ADMIXTURES SHALL BE INCORPORATED INTO CONCRETE MIX UNLESS PRE-APPROVED BY M.I.D. SEE M.I.D. STANDARD G 04 - CONCRETE NOTES\*.
2. ALL PIPE SHALL ENTER BOX AT OR NEAR PERPENDICULAR ANGLES TO THE BOX.
3. ALL COLD JOINTS REQUIRE 6" CENTER BULB RUBBER WATER STOP EMBEDDED IN CENTER OF WALL AT COLD JOINT LOCATION PER MANUFACTURER'S RECOMMENDATIONS. SEE M.I.D. STANDARD G 07 - NEW CONSTRUCTION JOINT\*.
4. CANAL GATE TO BE WATERMAN C-10 CANAL GATE WITH GALVANIZED FRAME OR PRE-APPROVED EQUIVALENT.
5. PROPERLY SEAL ALL BOX JOINTS AND PIPES BY MORTARING FROM INSIDE OF BOX. USE SOFT BRISTLE BRUSH TO BLEND MORTAR AND CONCRETE TOGETHER. SEE M.I.D. STANDARD G 11 - M.I.D. MORTAR MIX NOTES\*.
6. WATERSTOP SURROUNDING OPENINGS SHALL BE VOLCLAY WATERSTOP-RX 102 BENTONITE CLAY STRIP OR ADEKA ULTRASEAL KBA-1510FP WATERSTOP, PLACED AROUND OUTSIDE OF PIPE IN CENTER OF WALL.
7. IF TOP OF STRUCTURE IS 4 FEET OR MORE ABOVE SURROUNDING GRADE, A LADDER SHALL BE REQUIRED. IF TOP OF STRUCTURE IS 7.5 FEET OR MORE ABOVE SURROUNDING GRADE, HANDRAILING SHALL ALSO BE REQUIRED. REFER TO M.I.D. STANDARDS M 45 - STRUCTURE HANDRAILING\* AND M 46 STRUCTURE LADDER\*.

REV	CHANGE	DATE	BY
1	RELEASE	06/17	LH
2	REVISED	04/22	LH
3			
4			

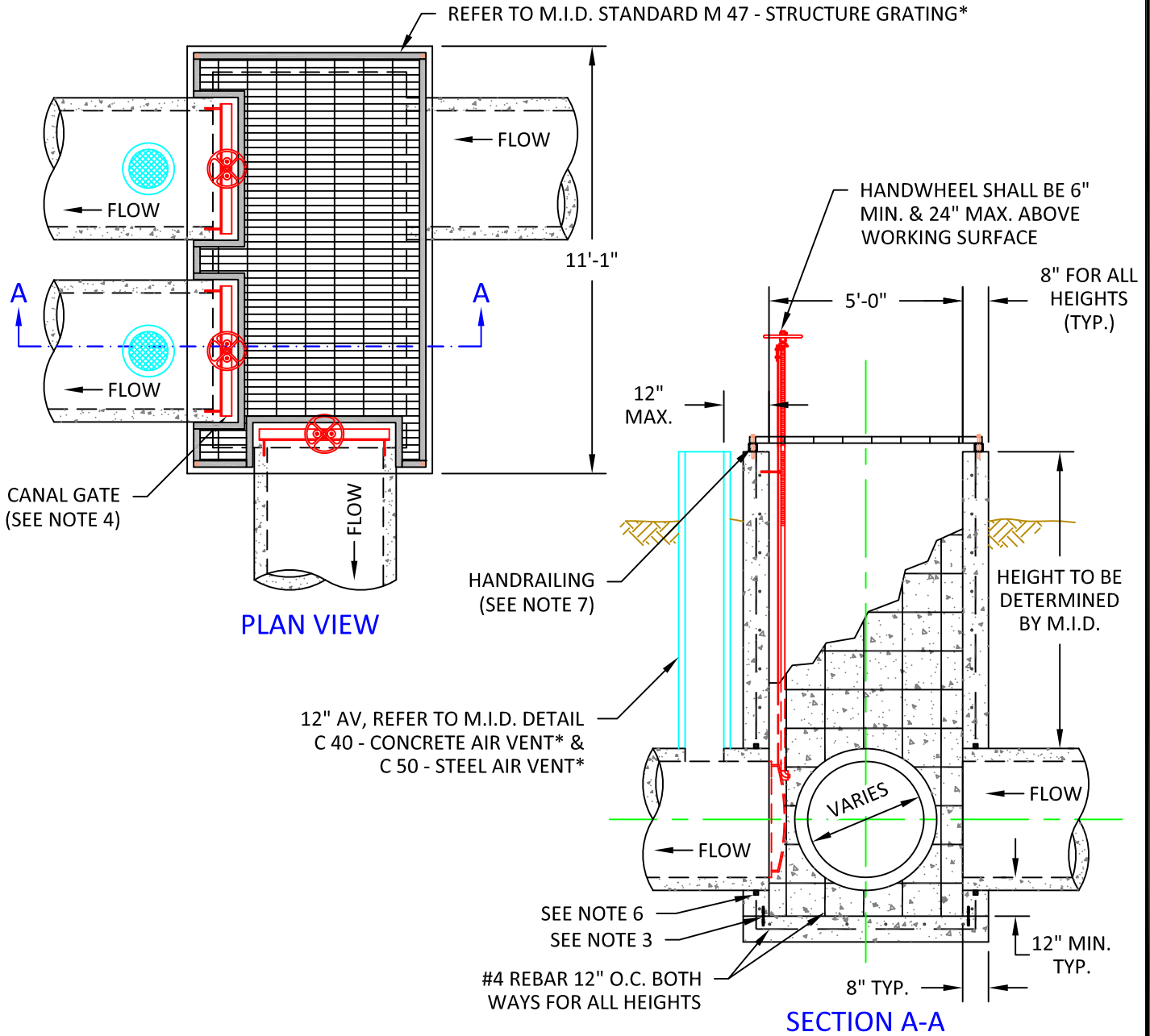

**LONG CONTROL BOX FOR CONCRETE PIPELINE**

DATE: JUNE 2017

STANDARD #:

C 75

SCALE: NONE

APPROVED BY:

*David B. Bakker*

DAVID B. BAKKER, P.E.  
SENIOR CIVIL ENGINEER

DATE: 4/29/22

**NOTES:**

1. ONLY TO BE USED WHEN AN EXISTING ACCESS POINT IS NOT IN PROXIMITY OF THE AREA OF PIPELINE REPAIR OR ONE CANNOT BE CONSTRUCTED. PRE-APPROVAL BY M.I.D. ENGINEER REQUIRED FOR ALL APPLICATIONS.
2. THOROUGHLY BRUSH ALL DEBRIS AND CLEAN AROUND ACCESS HOLE WITH WATER PRIOR TO PLACEMENT OF PATCH AND MORTAR.
3. MINIMUM #4 BARS FOR ACCESS HOLE PATCH REINFORCEMENT.
4. TWO BARS REQUIRED TO BE PLACED OVER PATCH. BARS MUST EXTEND 4" PAST EDGE OF ACCESS HOLE.
5. MINIMUM #16 GAUGE WIRES TO BE USED TO ATTACH TIN INSERT TO EACH #4 REINFORCEMENT BAR.
6. PROPERLY SEAL ACCESS HOLE PATCH AND REBAR REINFORCEMENT BY MORTARING. USE SOFT BRISTLE BRUSH TO BLEND MORTAR AND CONCRETE TOGETHER. SEE M.I.D. STANDARD G 11 - M.I.D. MORTAR MIX NOTES\*.

REV	CHANGE	DATE	BY
1	RELEASE	06/17	LH
2	REVISED	04/22	LH
3			
4			

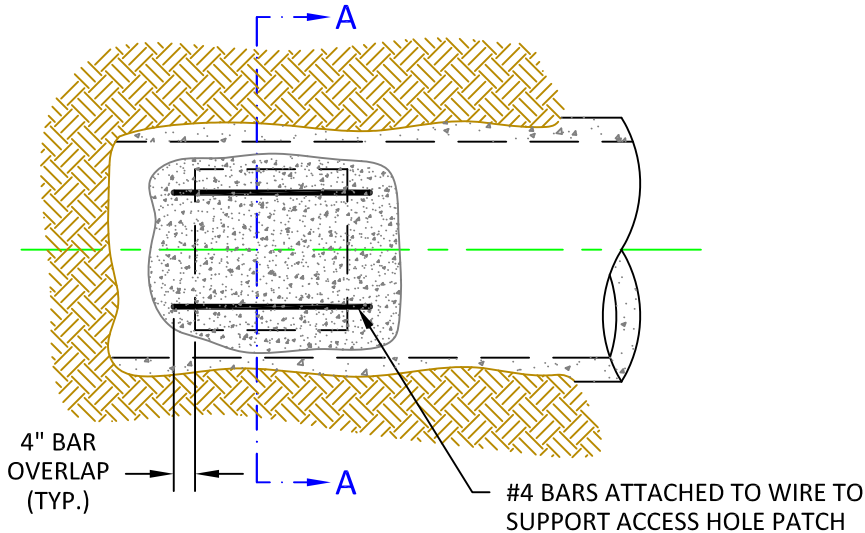

**PLAN VIEW**

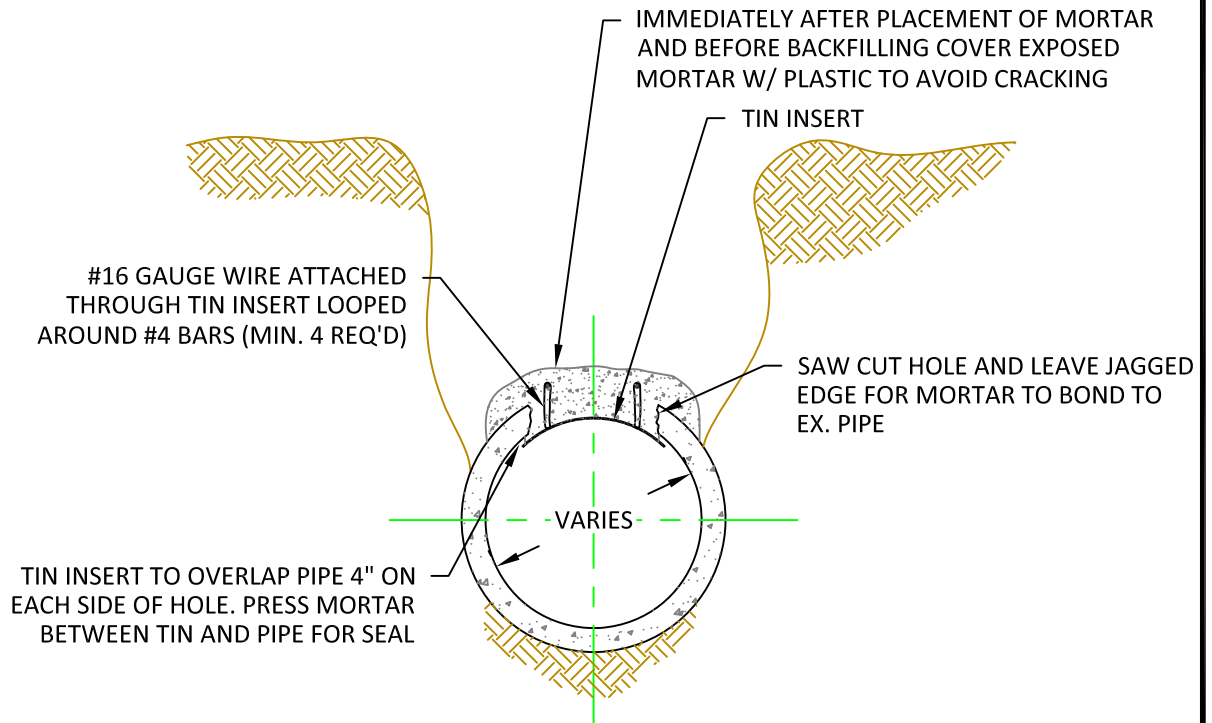

**SECTION A-A**

\*REFERENCED STANDARD(S): G 11



**ACCESS HOLE FOR CONCRETE PIPELINE**

DATE: JUNE 2017

STANDARD #:

C 99

SCALE: NONE

APPROVED BY:

*David B. Bakker*

DAVID B. BAKKER, P.E.  
SENIOR CIVIL ENGINEER

DATE: 4/29/22



**NOTES:**

1. CONCRETE STRENGTH TO BE 3,000 PSI @ 28 DAYS. NO ADMIXTURES SHALL BE INCORPORATED INTO CONCRETE MIX UNLESS PRE-APPROVED BY M.I.D. SEE M.I.D. STANDARD G 04 - CONCRETE NOTES\*.
2. SEE M.I.D. STANDARD G 08 - CONCRETE LINED CANAL NOTES\*.

REV	CHANGE	DATE	BY
1	RELEASE	06/17	LH
2			
3			
4			

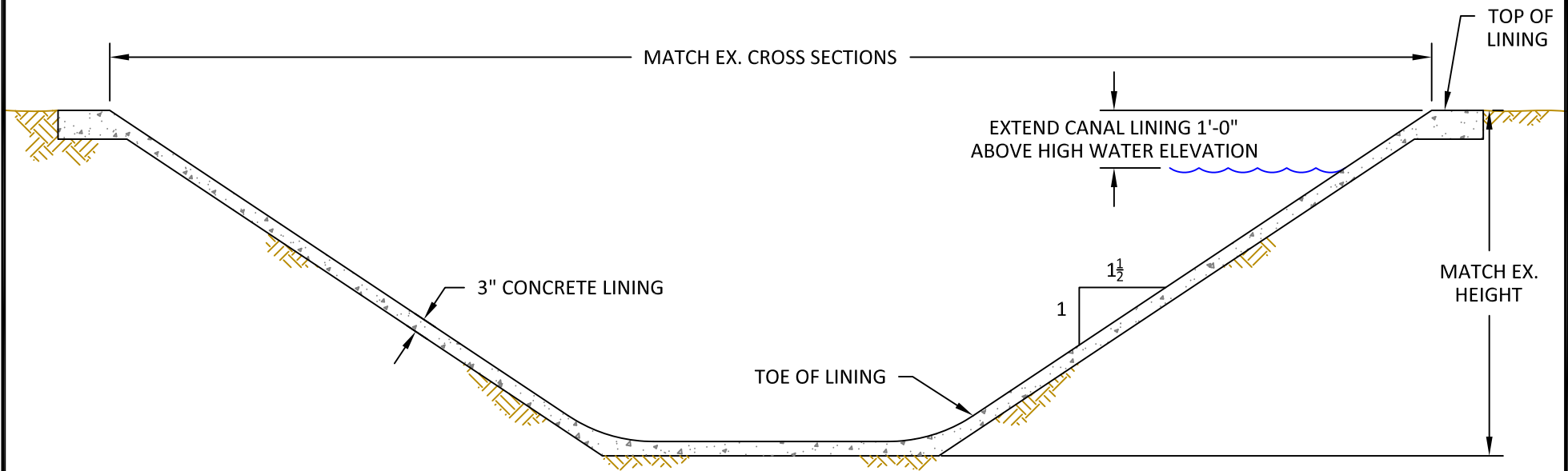

\*REFERENCED STANDARD(S): G 04, G 08

**TYPICAL CANAL CROSS SECTION**



DATE: JUNE 2017

SCALE: NONE

STANDARD #: CL 10

APPROVED BY:

CHAD J. TIENKEN, P.E., P.L.S.  
CIVIL ENGINEERING MANAGER

9/7/17

DATE

**NOTES:**

1. CONCRETE STRENGTH TO BE 3,000 PSI @ 28 DAYS. NO ADMIXTURES SHALL BE INCORPORATED INTO CONCRETE MIX UNLESS PRE-APPROVED BY M.I.D. SEE M.I.D. STANDARD G 04 - CONCRETE NOTES\*.
2. CONSTRUCT STEPS ON BOTH BANKS AT WEIRS AND EACH SIDE OF BRIDGES UNLESS OTHERWISE DIRECTED BY M.I.D. ENGINEER.

REV	CHANGE	DATE	BY
1	RELEASE	06/17	LH
2			
3			
4			

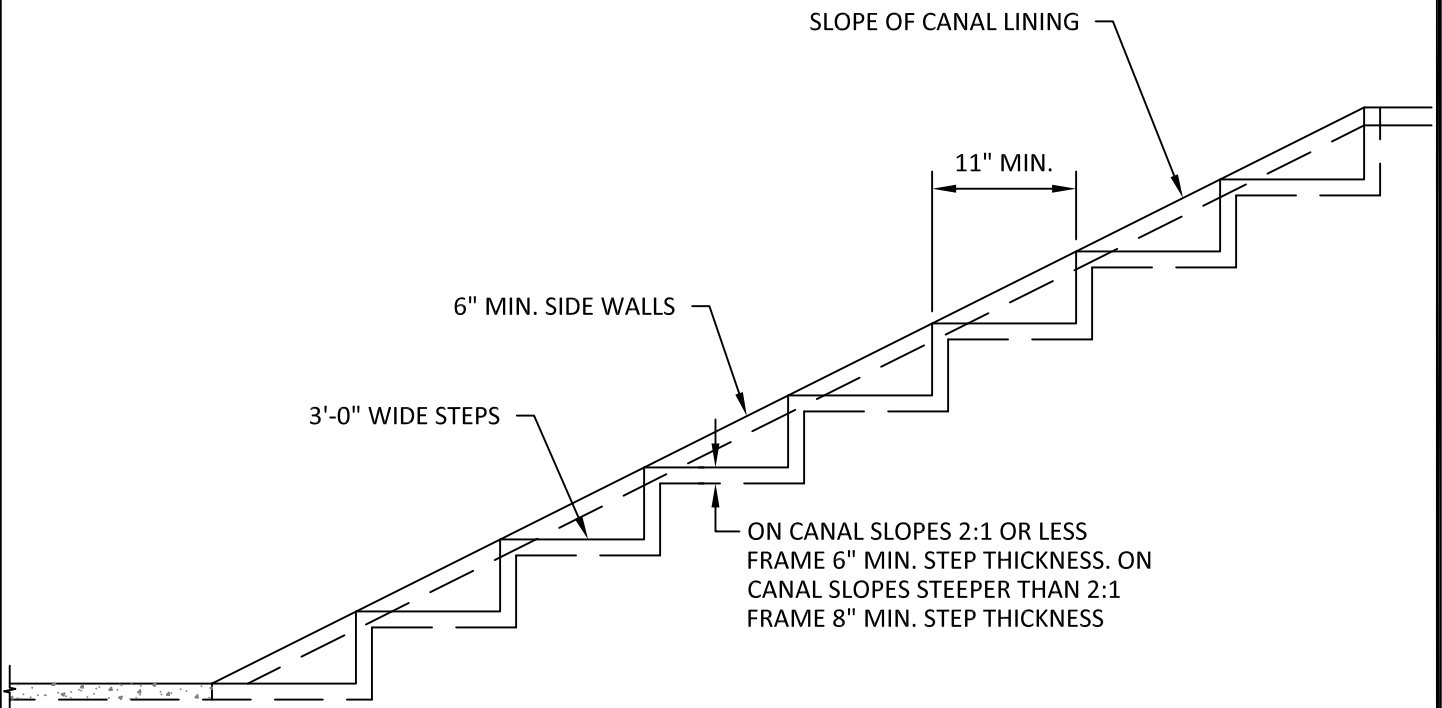

**CROSS SECTION VIEW**

\*REFERENCED STANDARD(S): G 04



**CANAL STEP DETAIL**

DATE: JUNE 2017

STANDARD #:

CL 15

SCALE: NONE

APPROVED BY:

CHAD J. TIENKEN, P.E., P.L.S.  
CIVIL ENGINEERING MANAGER

DATE: 9/7/17

REV	CHANGE	DATE	BY
1	RELEASE	06/17	LH
2	REVISED	04/22	LH
3			
4			

**NOTES:**

1. THIS STANDARD APPLIES TO PROPOSED UTILITIES CROSSING M.I.D. FACILITIES LYING WITHIN M.I.D. PROPERTY OR M.I.D. EASEMENTS.
2. IN ALL CASES THERE SHALL BE NO LESS THAN 30 INCHES OF COVER OVER THE CASING PIPE EXCEPT UNDER THE M.I.D. PIPELINE OR CANAL.
3. ALL UTILITY CROSSINGS SHALL BE A MINIMUM OF SCHEDULE 40 PIPE, 100 PSI PVC, WELDED HDPE PIPE OR REINFORCED CONCRETE PIPE (RCP). ALL AGRICULTURAL CROSSINGS SHALL BE A MINIMUM OF SCHEDULE 40 PIPE OR 100 PSI PVC. CLASS OF PIPE MAY BE INCREASED AS DIRECTED BY M.I.D. ENGINEER. ALL PIPE JOINTS SHALL BE WELDED OR GLUED, NO GASKETED JOINTS SHALL BE ALLOWED UNLESS PRE-APPROVED BY M.I.D. ENGINEER. ALL OTHER PIPE AND PIPE CLASSES SHALL BE PRE-APPROVED BY M.I.D. ENGINEER.
4. WHENEVER ANY PROPOSED UTILITY IS TO CROSS EXISTING M.I.D. FACILITIES (PIPELINE, UNLINED DITCH OR LINED CANAL) LYING WITHIN M.I.D. PROPERTY OR M.I.D. EASEMENTS/RIGHT OF WAY, IT SHALL BE ACCOMPLISHED BY HORIZONTAL AUGER BORING OF A STEEL CASING PIPE RUNNING CONTINUOUSLY THE FULL WIDTH OR BY DIRECTIONAL DRILLING.
5. BORE PITS AND RECEIVING PITS SHALL ONLY BE PLACED OUTSIDE OF M.I.D. PROPERTY OR EASEMENTS/RIGHTS OF WAY. BORE PITS SHALL COMPLY WITH CAL-OSHA CONSTRUCTION SAFETY REQUIREMENTS. BORE PITS AND RECEIVING PITS SHALL BE SECURELY FENCED OR COVERED DURING NON-WORKING HOURS.
6. JACKING OF CASING PIPES WILL BE PERMITTED ONLY BY SPECIAL PERMISSION FROM M.I.D. ENGINEER.
7. ONCE THE BORING OPERATION HAS COMMENCED, IT SHALL BE CONTINUED, UNINTERRUPTED, AROUND THE CLOCK, UNTIL THE CASING PIPE HAS BEEN INSTALLED TO THE SPECIFIED LIMITS. ONCE BORING WORK IS COMPLETE BORE PIT AND RECEIVING PIT SHALL BE BACKFILLED AND COMPACTED IN 8" LIFTS.
8. THE INSIDE DIAMETER OF THE CASING PIPES SHALL BE AS LARGE AS NECESSARY FOR THE INSTALLATION OF THE CARRIER PIPE AND SKIDS. IN NO CASE SHALL IT BE LESS THAN 2 INCHES LARGER THAN THE LARGEST OUTSIDE DIAMETER OF THE CARRIER PIPE. CASING PIPES SHALL CONFORM TO THE TABLE BELOW AND SHALL BE SEAMLESS OR WELDED SEAM PIPE AND SHALL BE COATED INSIDE WITH A BITUMINOUS COATING. IF A BITUMINOUS COATING CANNOT BE USED ON THE INSIDE OF THE CASING PIPE, THE CASING PIPE MINIMUM THICKNESS SHALL BE INCREASED 1/16 INCH.

**CASING THICKNESS:**

CASING ID	MINIMUM THICKNESS
4"-10"	1/4"
12"-36"	3/8"
42"-48"	1/2"
LARGER	TO BE DETERMINED BY M.I.D. ENGINEER

9. CARRIER PIPES SHALL BE SUITABLE FOR TRANSPORTING THE PRODUCT INTENDED AND SHALL HAVE COMPRESSION SEALING JOINTS AT EACH END OF THE CROSSING.
10. CASING PIPES FOR CARRIER PIPES SHALL BE SEALED (PLUGGED) AT EACH END. CASING PIPES CARRYING ELECTRICAL CONDUCTORS SHALL BE GROUNDED WITH A GROUNDING ROD IN ACCORDANCE WITH THE NATIONAL ELECTRIC CODE.
11. ALL VENT PIPES & APPURTENANCES TO BE LOCATED OUTSIDE OF M.I.D. RIGHT-OF-WAY.
12. BORINGS SHALL NOT BE PERFORMED DURING THE IRRIGATION SEASON (TYPICALLY MARCH 1 TO OCTOBER 30) OR IN SATURATED GROUND WITHOUT SPECIFIC WRITTEN PERMISSION FROM M.I.D. ENGINEER.
13. THE DIAMETER OF THE BORED HOLE SHALL NOT BE MORE THAN 0.1 FEET GREATER THAN THE CASING PIPE OUTSIDE DIAMETER. A SHIELD OR BAND MAY BE USED ON THE FIRST SECTION OF PIPE. VOIDS RESULTING FROM CAVING OR EXCAVATING OUTSIDE OF THE ABOVE LIMITS SHALL BE BACKFILLED WITH SAND OR GROUT BY AN APPROPRIATE METHOD WHICH WILL FILL THE VOIDS, AS PRE-APPROVED BY M.I.D. ENGINEER.
14. WHERE THE DEPTH OF AN M.I.D. PIPELINE IS UNKNOWN, IT SHALL BE THE SOLE RESPONSIBILITY OF THE CONTRACTOR TO LOCATE THE PIPELINE. ONLY HAND AUGERING SHALL BE PERMITTED. ALLOW ADEQUATE DEPTH OF CASING PIPE TO INSURE THE SPECIFIED MINIMUM CLEARANCE.
15. M.I.D. ENGINEER SHALL CONFIRM THAT THERE ARE NO SIGNS OF LEAKAGE AT M.I.D. FACILITY PRIOR TO CROSSING WORK. IF LEAKAGE BECOMES APPARENT AFTER THE CROSSING WORK IS PERFORMED AND IT IS DETERMINED, SOLELY BY THE M.I.D. ENGINEER, THAT THE LEAKAGE IS A RESULT OF DAMAGE TO THE FACILITY IN CONNECTION WITH THE CROSSING PROJECT THEN REPAIR OF THE FACILITY WILL BE PERFORMED SOLELY AT THE EXPENSE OF THE CONTRACTOR OR PROJECT PROPONENT. M.I.D. SHALL BEAR NO EXPENSE IN RELATION TO THE PROJECT OR REPAIR.
16. AT THE COMPLETION OF WORK UTILITY CROSSING MARKERS SHALL BE INSTALLED. SEE M.I.D. STANDARD CR 20 - UTILITY CROSSING MARKER\*.

\*REFERENCED STANDARD(S): CR 20



**BORING GENERAL NOTES**

DATE: JUNE 2017

STANDARD #:

CR 01

SCALE: NONE

APPROVED BY:

*David B. Bakker*

DAVID B. BAKKER, P.E.  
SENIOR CIVIL ENGINEER

DATE: 4/29/22

**NOTES:**

1. SEE M.I.D. STANDARD CR 01 - BORING GENERAL NOTES\*.
2. MINIMUM CLEARANCE BETWEEN BOTTOM OF CANAL AND CARRIER PIPE TO BE OBSERVED DURING INSTALLATION: 4'-0" MIN. FOR GAS, FIBER OPTIC, ELECTRICAL AND CABLE UTILITIES; 2'-0" FOR IRRIGATION, WATER, SEWER AND STORM DRAIN LINES. ALL DEPTHS TO BE APPROVED BY M.I.D.
3. BORE PIT AND RECEIVING PIT SHALL ONLY BE PLACED OUTSIDE OF M.I.D. PROPERTY OR EASEMENTS/RIGHTS-OF-WAY. BORE PIT SHALL COMPLY WITH CAL/OSHA CONSTRUCTION SAFETY REQUIREMENTS. BORE PIT AND RECEIVING PIT SHALL BE SECURELY FENCED DURING NON-WORKING HOURS AND BACKFILLED WITH ENGINEERED FILL WHEN NO LONGER REQUIRED.
4. CASING PIPE SHALL EXTEND 5' MINIMUM OUTSIDE OF M.I.D. RIGHT-OF-WAY.
5. NOTIFY OWNERS OF SUBSURFACE UTILITIES ALONG AND ON EITHER SIDE OF THE PROPOSED DRILL PATH OF THE IMPENDING WORK THROUGH UNDERGROUND SERVICE ALERT. ALL UTILITIES ALONG AND ON EITHER SIDE OF THE PROPOSED DRILL PATH ARE TO BE LOCATED.
6. CONTRACTOR/LANDOWNER SHALL OBTAIN ALL NECESSARY PERMITS OR AUTHORIZATIONS TO PERFORM THE BORING WORK.
  - 6.1. NOTE: A TUNNEL IS DEFINED AS ANY INSTALLATION THAT IS 30" OR LARGER IN DIAMETER AND IS SUBJECT TO ADDITIONAL PERMIT REQUIREMENTS AND INSPECTION BY CAL/OSHA.
7. ALL VENT PIPES AND APPURTENANCES TO BE LOCATED OUTSIDE OF M.I.D. RIGHT-OF-WAY.

REV	CHANGE	DATE	BY
1	RELEASE	04/22	LH
2			
3			
4			

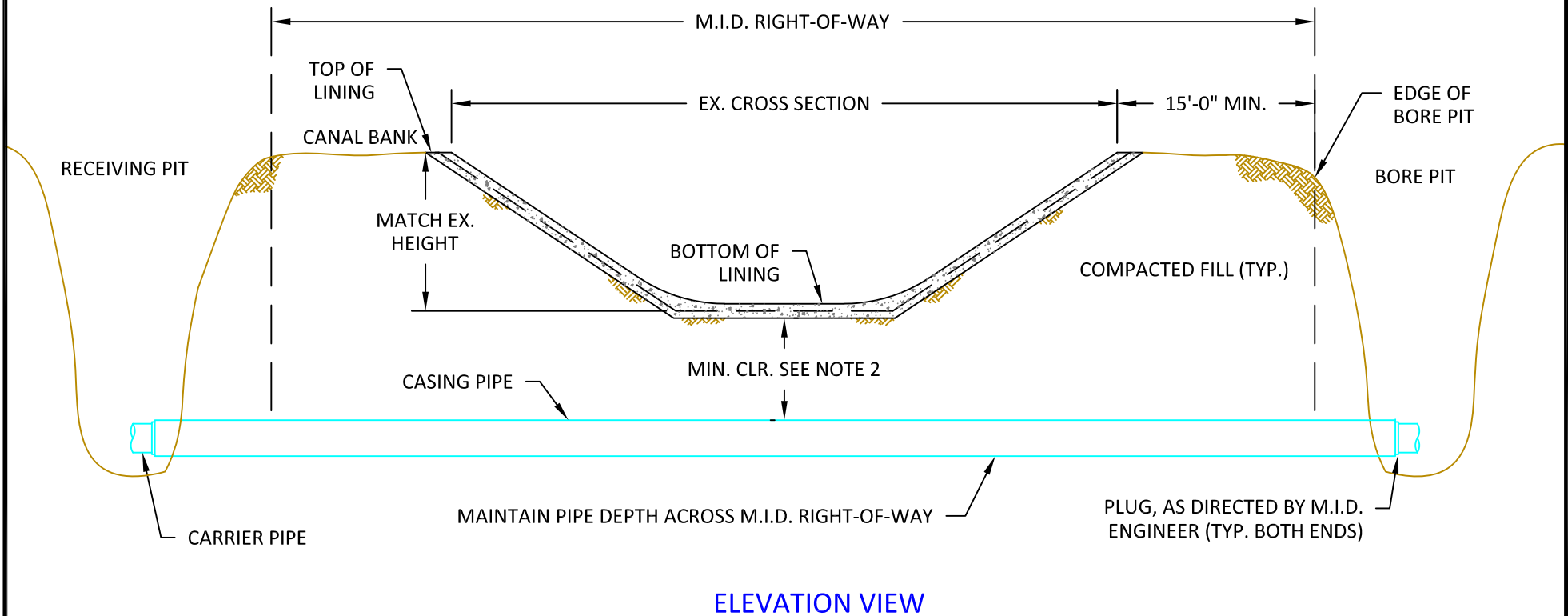

**ELEVATION VIEW**

\*REFERENCED STANDARD(S): CR 01



**JACK & BORE PIPELINE CROSSING  
UNDER M.I.D. CANAL**

DATE: APRIL 2022

SCALE: NONE

STANDARD #:

CR 02

APPROVED BY:

*David B. Bakker*

DAVID B. BAKKER, P.E.  
SENIOR CIVIL ENGINEER

4/29/22

DATE

**NOTES:**

1. SEE M.I.D. STANDARD CR 01 - BORING GENERAL NOTES\*.
2. MINIMUM CLEARANCE BETWEEN BOTTOM OF M.I.D. PIPELINE AND CARRIER PIPE TO BE OBSERVED DURING INSTALLATION: 4'-0" MIN. FOR GAS, FIBER OPTIC, ELECTRICAL AND CABLE UTILITIES; 2'-0" FOR IRRIGATION, WATER, SEWER AND STORM DRAIN LINES. ALL DEPTHS TO BE APPROVED BY M.I.D.
3. BORE PIT AND RECEIVING PIT SHALL ONLY BE PLACED OUTSIDE OF M.I.D. PROPERTY OR EASEMENTS/RIGHTS-OF-WAY. BORE PIT SHALL COMPLY WITH CAL/OSHA CONSTRUCTION SAFETY REQUIREMENTS. BORE PIT AND RECEIVING PIT SHALL BE SECURELY FENCED DURING NON-WORKING HOURS AND BACKFILLED WITH ENGINEERED FILL WHEN NO LONGER REQUIRED.
4. CASING PIPE SHALL EXTEND 5' MINIMUM OUTSIDE OF M.I.D. RIGHT-OF-WAY.
5. NOTIFY OWNERS OF SUBSURFACE UTILITIES ALONG AND ON EITHER SIDE OF THE PROPOSED DRILL PATH OF THE IMPENDING WORK THROUGH UNDERGROUND SERVICE ALERT. ALL UTILITIES ALONG AND ON EITHER SIDE OF THE PROPOSED DRILL PATH ARE TO BE LOCATED.
6. CONTRACTOR/LANDOWNER SHALL OBTAIN ALL NECESSARY PERMITS OR AUTHORIZATIONS TO PERFORM THE BORING WORK.
  - 6.1. NOTE: A TUNNEL IS DEFINED AS ANY INSTALLATION THAT IS 30" OR LARGER IN DIAMETER AND IS SUBJECT TO ADDITIONAL PERMIT REQUIREMENTS AND INSPECTION BY CAL/OSHA.
7. ALL VENT PIPES AND APPURTENANCES TO BE LOCATED OUTSIDE OF M.I.D. RIGHT-OF-WAY.

REV	CHANGE	DATE	BY
1	RELEASE	04/22	LH
2			
3			
4			

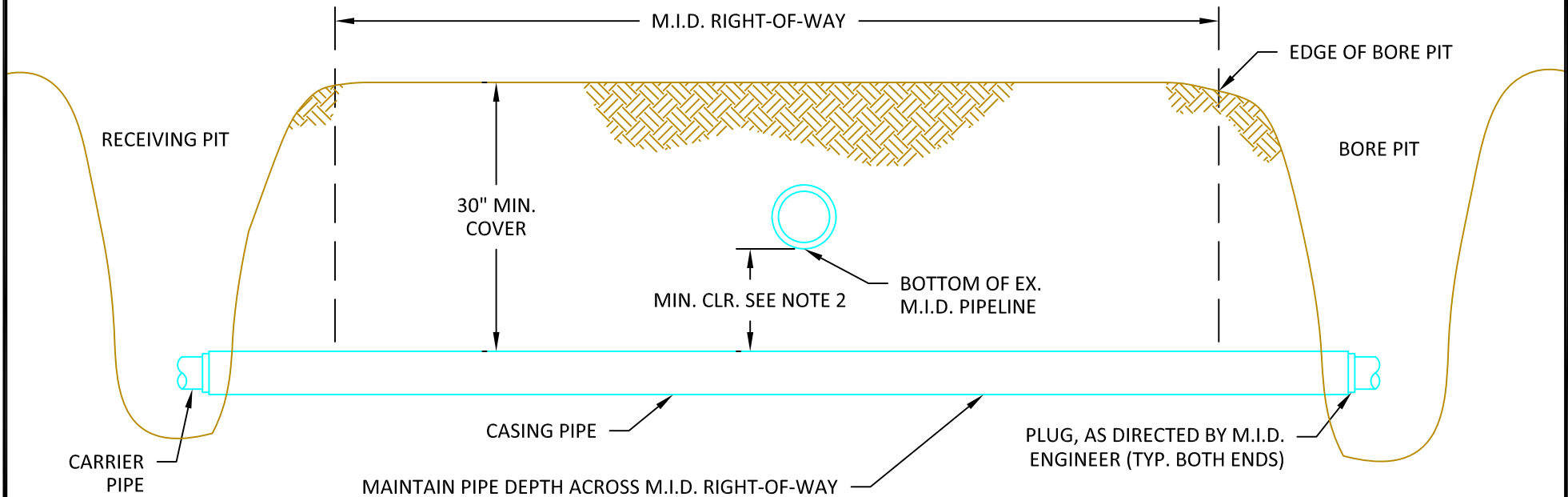

\*REFERENCED STANDARD(S): CR 01



**JACK & BORE PIPELINE CROSSING  
UNDER M.I.D. PIPELINE**

DATE: APRIL 2022

SCALE: NONE

STANDARD #:

CR 03

APPROVED BY:

*David B. Bakker*

DAVID B. BAKKER, P.E.  
SENIOR CIVIL ENGINEER

4/29/22

DATE

**NOTES:**

1. SEE M.I.D. STANDARD CR 01 - BORING GENERAL NOTES\*.
2. MINIMUM CLEARANCE BETWEEN BOTTOM OF CANAL AND CARRIER PIPE TO BE OBSERVED DURING INSTALLATION: 4'-0" MIN. FOR GAS, FIBER OPTIC, ELECTRICAL AND CABLE UTILITIES; 2'-0" FOR IRRIGATION, WATER, SEWER AND STORM DRAIN LINES. ALL DEPTHS TO BE APPROVED BY M.I.D.
3. BORE PIT AND RECEIVING PIT SHALL ONLY BE PLACED OUTSIDE OF M.I.D. PROPERTY OR EASEMENTS/RIGHTS-OF-WAY. BORE PIT SHALL COMPLY WITH CAL/OSHA CONSTRUCTION SAFETY REQUIREMENTS. BORE PIT AND RECEIVING PIT SHALL BE SECURELY FENCED DURING NON-WORKING HOURS AND BACKFILLED WITH ENGINEERED FILL WHEN NO LONGER REQUIRED.
4. BORE PIPE SHALL EXTEND 5' MINIMUM OUTSIDE OF M.I.D. RIGHT-OF-WAY.
5. NOTIFY OWNERS OF SUBSURFACE UTILITIES ALONG AND ON EITHER SIDE OF THE PROPOSED DRILL PATH OF THE IMPENDING WORK THROUGH UNDERGROUND SERVICE ALERT. ALL UTILITIES ALONG AND ON EITHER SIDE OF THE PROPOSED DRILL PATH ARE TO BE LOCATED.
6. CONTRACTOR/LANDOWNER SHALL OBTAIN ALL NECESSARY PERMITS OR AUTHORIZATIONS TO PERFORM THE BORING WORK.
  - 6.1. NOTE: A TUNNEL IS DEFINED AS ANY INSTALLATION THAT IS 30" OR LARGER IN DIAMETER AND IS SUBJECT TO ADDITIONAL PERMIT REQUIREMENTS AND INSPECTION BY CAL/OSHA.
7. ALL VENT PIPES AND APPURTENANCES TO BE LOCATED OUTSIDE M.I.D. RIGHT-OF-WAY.

REV	CHANGE	DATE	BY
1	RELEASE	04/22	LH
2			
3			
4			

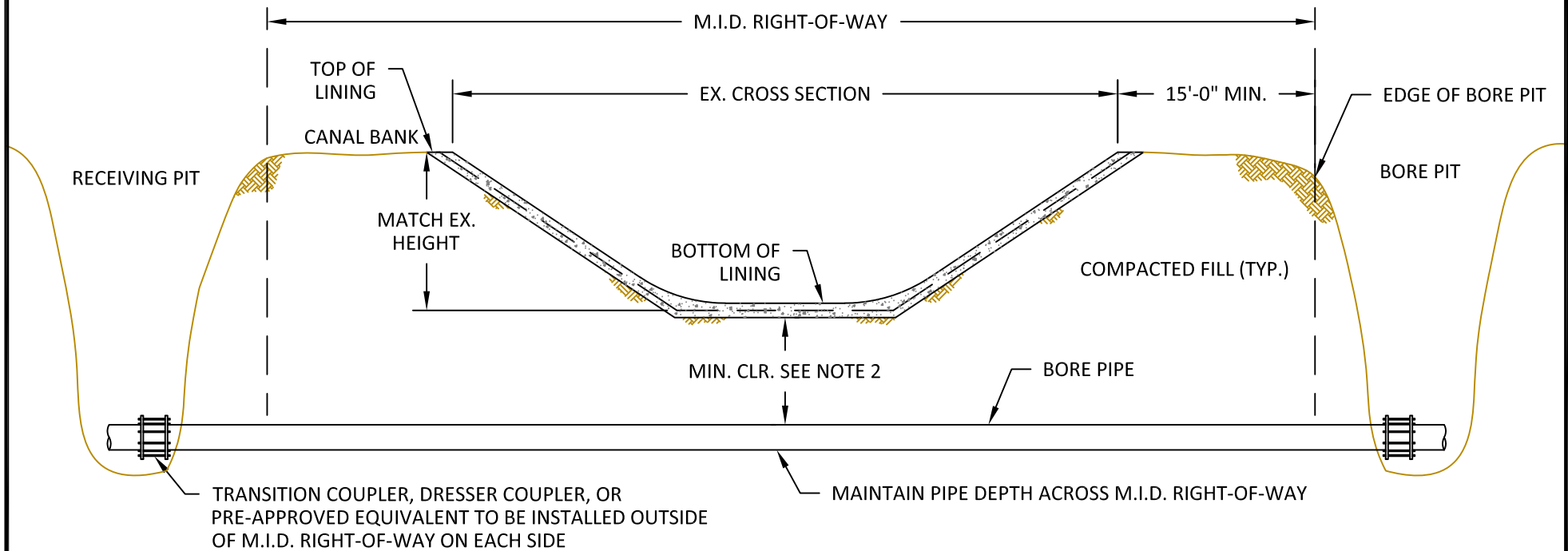

**ELEVATION VIEW**

\*REFERENCED STANDARD(S): CR 01



**DIRECTIONAL BORING PIPELINE CROSSING UNDER M.I.D. CANAL**

DATE: APRIL 2022  
SCALE: NONE

STANDARD #:  
CR 04

APPROVED BY:

*David B. Bakker*

DAVID B. BAKKER, P.E.  
SENIOR CIVIL ENGINEER

4/29/22  
DATE

**NOTES:**

1. SEE M.I.D. STANDARD CR 01 - BORING GENERAL NOTES\*.
2. MINIMUM CLEARANCE BETWEEN BOTTOM OF M.I.D. PIPELINE AND CARRIER PIPE TO BE OBSERVED DURING INSTALLATION: 4'-0" MIN. FOR GAS, FIBER OPTIC, ELECTRICAL AND CABLE UTILITIES; 2'-0" FOR IRRIGATION, WATER, SEWER AND STORM DRAIN LINES. ALL DEPTHS TO BE APPROVED BY M.I.D.
3. BORE PIT AND RECEIVING PIT SHALL ONLY BE PLACED OUTSIDE OF M.I.D. PROPERTY OR EASEMENTS/RIGHTS-OF-WAY. BORE PIT SHALL COMPLY WITH CAL/OSHA CONSTRUCTION SAFETY REQUIREMENTS. BORE PIT AND RECEIVING PIT SHALL BE SECURELY FENCED DURING NON-WORKING HOURS AND BACKFILLED WITH ENGINEERED FILL WHEN NO LONGER REQUIRED.
4. BORE PIPE SHALL EXTEND 5' MINIMUM OUTSIDE OF M.I.D. RIGHT-OF-WAY.
5. NOTIFY OWNERS OF SUBSURFACE UTILITIES ALONG AND ON EITHER SIDE OF THE PROPOSED DRILL PATH OF THE IMPENDING WORK THROUGH UNDERGROUND SERVICE ALERT. ALL UTILITIES ALONG AND ON EITHER SIDE OF THE PROPOSED DRILL PATH ARE TO BE LOCATED.
6. CONTRACTOR/LANDOWNER SHALL OBTAIN ALL NECESSARY PERMITS OR AUTHORIZATIONS TO PERFORM THE BORING WORK.
  - 6.1. NOTE: A TUNNEL IS DEFINED AS ANY INSTALLATION THAT IS 30" OR LARGER IN DIAMETER AND IS SUBJECT TO ADDITIONAL PERMIT REQUIREMENTS AND INSPECTION BY CAL/OSHA.
7. ALL VENT PIPES AND APPURTENANCES TO BE LOCATED OUTSIDE OF M.I.D. RIGHT-OF-WAY.

REV	CHANGE	DATE	BY
1	RELEASE	04/22	LH
2			
3			
4			

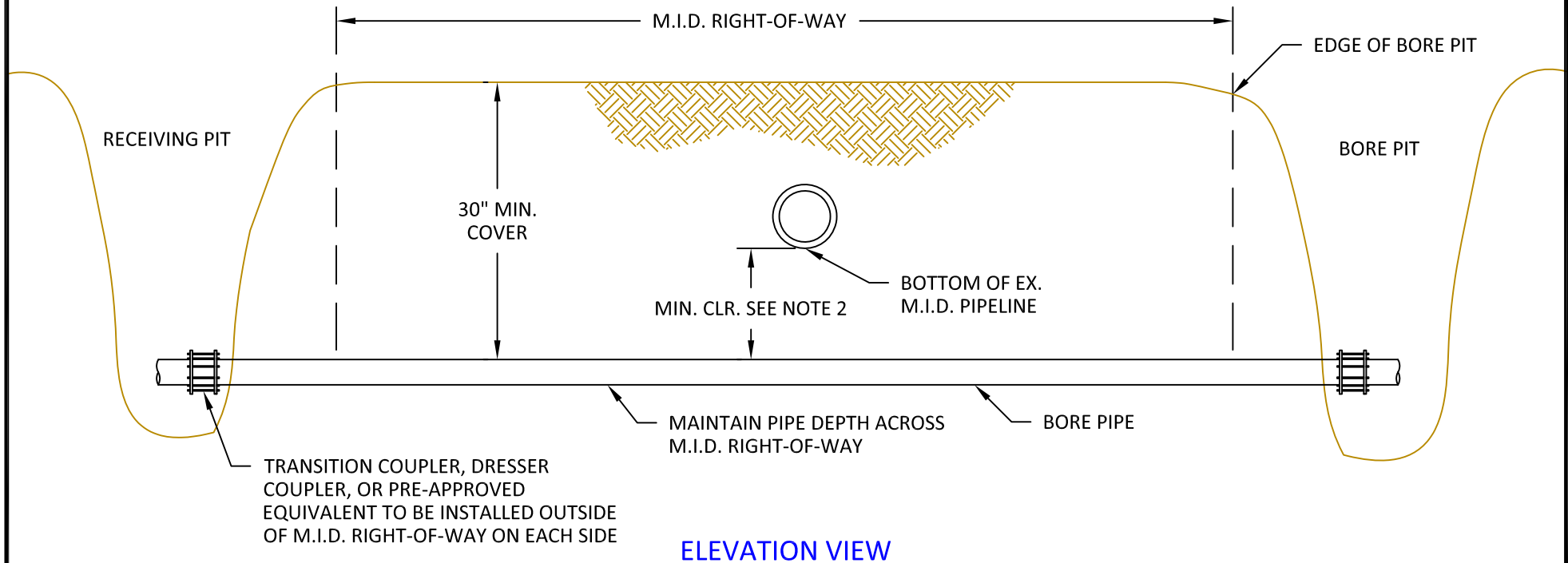

\*REFERENCED STANDARD(S): CR 01



**DIRECTIONAL BORING PIPELINE CROSSING  
UNDER M.I.D. PIPELINE**

DATE: APRIL 2022

SCALE: NONE

STANDARD #:

CR 05

APPROVED BY:

*David B. Bakker*

DAVID B. BAKKER, P.E.  
SENIOR CIVIL ENGINEER

4/29/22

DATE

REV	CHANGE	DATE	BY
1	RELEASE	06/17	LH
2	REVISED	04/22	LH
3			
4			

**NOTES:**

1. WHERE DEPTH OF AN M.I.D. PIPELINE IS UNKNOWN, IT SHALL BE THE SOLE RESPONSIBILITY OF THE CONTRACTOR TO LOCATE THE PIPELINE. ONLY HAND AUGURING SHALL BE PERMITTED.
2. TRENCH WORK SHALL COMPLY WITH CAL/OSHA CONSTRUCTION SAFETY REQUIREMENTS. SEE M.I.D. STANDARD G 09 - TRENCH BACKFILL\*.
3. IF LEAKAGE BECOMES APPARENT AFTER THE CROSSING WORK IS PERFORMED AND IT IS DETERMINED, SOLELY BY THE M.I.D. ENGINEER, THAT THE LEAKAGE IS A RESULT OF DAMAGE TO THE FACILITY IN CONNECTION WITH THE CROSSING PROJECT THEN REPAIR OF THE FACILITY WILL BE PERFORMED SOLELY AT THE EXPENSE OF THE CONTRACTOR OR PROJECT PROPONENT. M.I.D. SHALL BEAR NO EXPENSE IN RELATION OF THE PROJECT OR REPAIR.
4. CONTRACTOR SHALL INSTALL A CONTINUOUS FULL SECTION OF PIPE, CENTERED OVER THE M.I.D. PIPELINE BEING CROSSED TO ENSURE JOINTS WILL NOT AFFECT M.I.D. PIPELINE.
5. ALL UTILITY CROSSINGS SHALL BE A MINIMUM OF SCHEDULE 40 PIPE, 100 PSI PVC, WELDED HDPE PIPE OR REINFORCED CONCRETE PIPE (RCP). ALL AGRICULTURAL CROSSINGS SHALL BE A MINIMUM OF SCHEDULE 40 PIPE OR 100 PSI PVC. CLASS OF PIPE MAY BE INCREASED AS DIRECTED BY M.I.D. ENGINEER. ALL OTHER PIPE AND PIPE CLASSES SHALL BE PRE-APPROVED BY M.I.D. ENGINEER.
6. ALL VENT PIPES AND APPURTENANCES TO BE LOCATED OUTSIDE OF M.I.D. RIGHT-OF-WAY.
7. AT THE COMPLETION OF WORK UTILITY CROSSING MARKERS SHALL BE INSTALLED. SEE M.I.D. STANDARD CR 20 - UTILITY CROSSING MARKER\*.

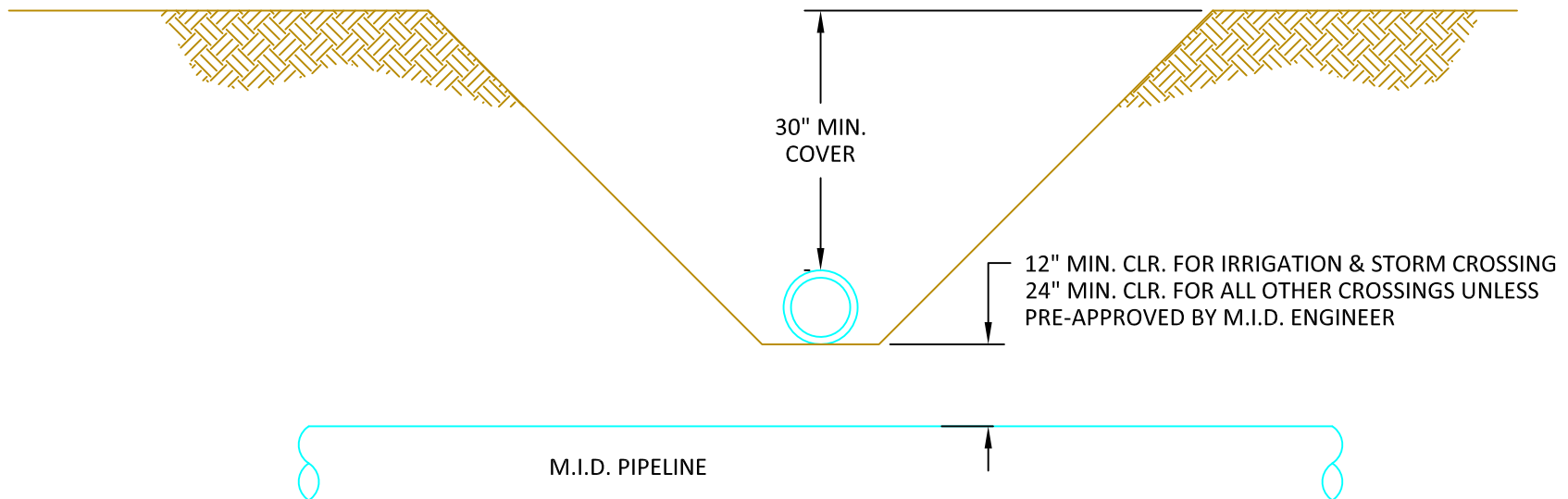

**ELEVATION VIEW**

\*REFERENCED STANDARD(S): G 09, CR 20



**PIPELINE CROSSING OVER M.I.D. PIPELINE  
USING OPEN-CUT TRENCH**

DATE: JUNE 2017

STANDARD #:

SCALE: NONE

CR 10

APPROVED BY:

*David B. Bakker*

DAVID B. BAKKER, P.E.  
SENIOR CIVIL ENGINEER

4/29/22

DATE



**NOTES:**

1. WHERE DEPTH OF AN M.I.D. PIPELINE IS UNKNOWN, IT SHALL BE THE SOLE RESPONSIBILITY OF THE CONTRACTOR TO LOCATE THE PIPELINE. ONLY HAND AUGURING SHALL BE PERMITTED.
2. TRENCH WORK SHALL COMPLY WITH CAL/OSHA CONSTRUCTION SAFETY REQUIREMENTS. SEE M.I.D. STANDARD G 09 - TRENCH BACKFILL\*.
3. IF LEAKAGE BECOMES APPARENT AFTER THE CROSSING WORK IS PERFORMED AND IT IS DETERMINED, SOLELY BY THE M.I.D. ENGINEER, THAT THE LEAKAGE IS A RESULT OF DAMAGE TO THE FACILITY IN CONNECTION WITH THE CROSSING PROJECT THEN REPAIR OF THE FACILITY WILL BE PERFORMED SOLELY AT THE EXPENSE OF THE CONTRACTOR OR PROJECT PROPONENT. M.I.D. SHALL BEAR NO EXPENSE IN RELATION OF THE PROJECT OR REPAIR.
4. CONTRACTOR SHALL INSTALL A CONTINUOUS FULL SECTION OF PIPE, CENTERED OVER THE M.I.D. PIPELINE BEING CROSSED TO ENSURE JOINTS WILL NOT AFFECT M.I.D. PIPELINE.
5. ALL UTILITY CROSSINGS SHALL BE A MINIMUM OF SCHEDULE 40 PIPE, 100 PSI PVC, WELDED HDPE PIPE OR REINFORCED CONCRETE PIPE (RCP). ALL AGRICULTURAL CROSSINGS SHALL BE A MINIMUM OF SCHEDULE 40 PIPE OR 100 PSI PVC. CLASS OF PIPE MAY BE INCREASED AS DIRECTED BY M.I.D. ENGINEER. ALL OTHER PIPE AND PIPE CLASSES SHALL BE PRE-APPROVED BY M.I.D. ENGINEER.
6. ALL VENT PIPES AND APPURTENANCES TO BE LOCATED OUTSIDE OF M.I.D. RIGHT-OF-WAY.
7. AT THE COMPLETION OF WORK UTILITY CROSSING MARKERS SHALL BE INSTALLED. SEE M.I.D. STANDARD CR 20 - UTILITY CROSSING MARKER\*.
8. MAXIMUM 6' CROSSING CUT UNLESS PRE-APPROVED BY M.I.D. ENGINEER

REV	CHANGE	DATE	BY
1	RELEASE	06/17	LH
2	REVISED	04/22	LH
3			
4			

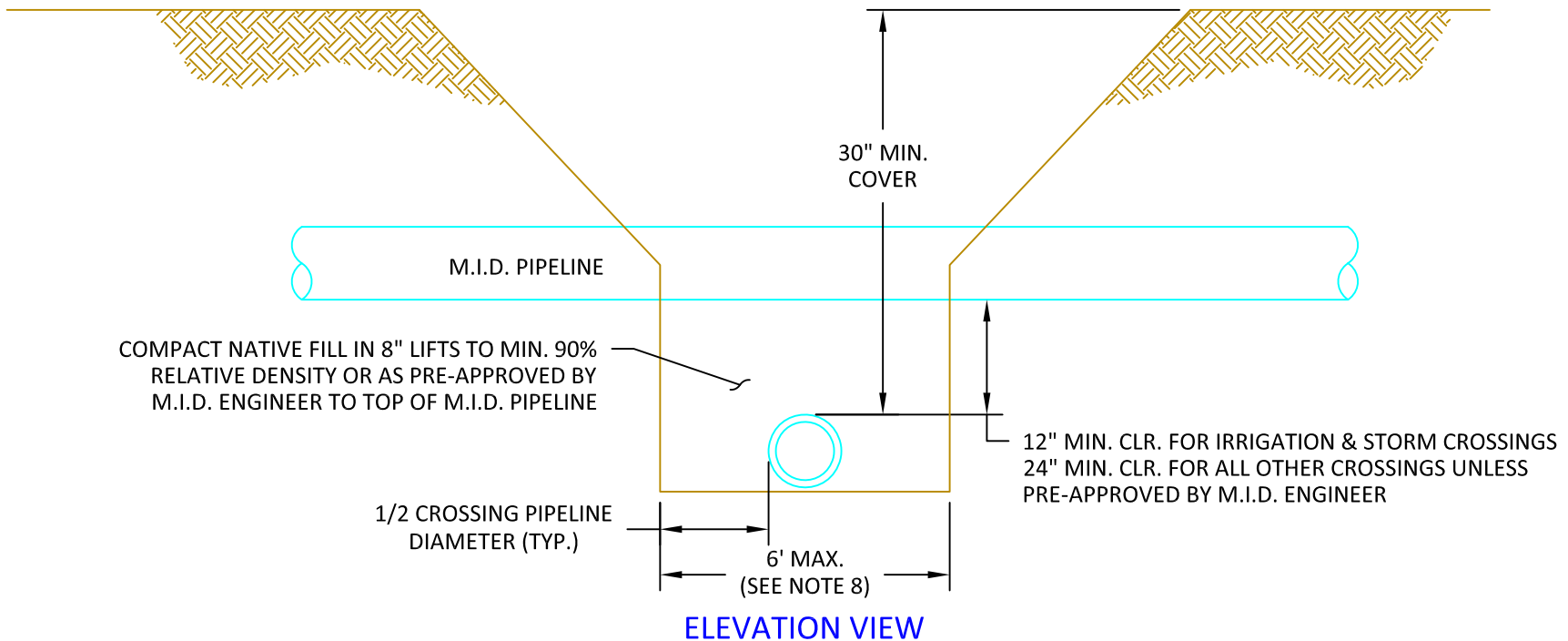

\*REFERENCED STANDARD(S): G 09, CR 20



**PIPELINE CROSSING UNDER M.I.D. PIPELINE  
USING OPEN-CUT TRENCH**

DATE: JUNE 2017  
SCALE: NONE

STANDARD #:  
**CR 11**

APPROVED BY:

*David B. Bakker*  
DAVID B. BAKKER, P.E.  
SENIOR CIVIL ENGINEER

4/29/22  
DATE

**NOTES:**

1. HEADWALLS SHALL BE CONSTRUCTED PERPENDICULAR TO M.I.D. LATERAL.
2. MINIMUM CLEAR DISTANCE SHALL BE MEASURED FROM THE EDGE OF PAVEMENT TO THE CLOSEST POINT ON THE HEADWALL.
3. HEADWALLS SHALL BE INSTALLED AT PROPERTY LINE, ROAD RIGHT OF WAY, PUBLIC UTILITY EASEMENT, OR 8 FEET FROM EDGE OF PAVEMENT, WHICHEVER IS GREATER.
4. UPSTREAM HEADWALLS MAY REQUIRE ADDITIONAL CLEARANCE FOR M.I.D. OPERATIONS.

REV	CHANGE	DATE	BY
1	RELEASE	06/17	LH
2	REVISED	04/22	LH
3			
4			

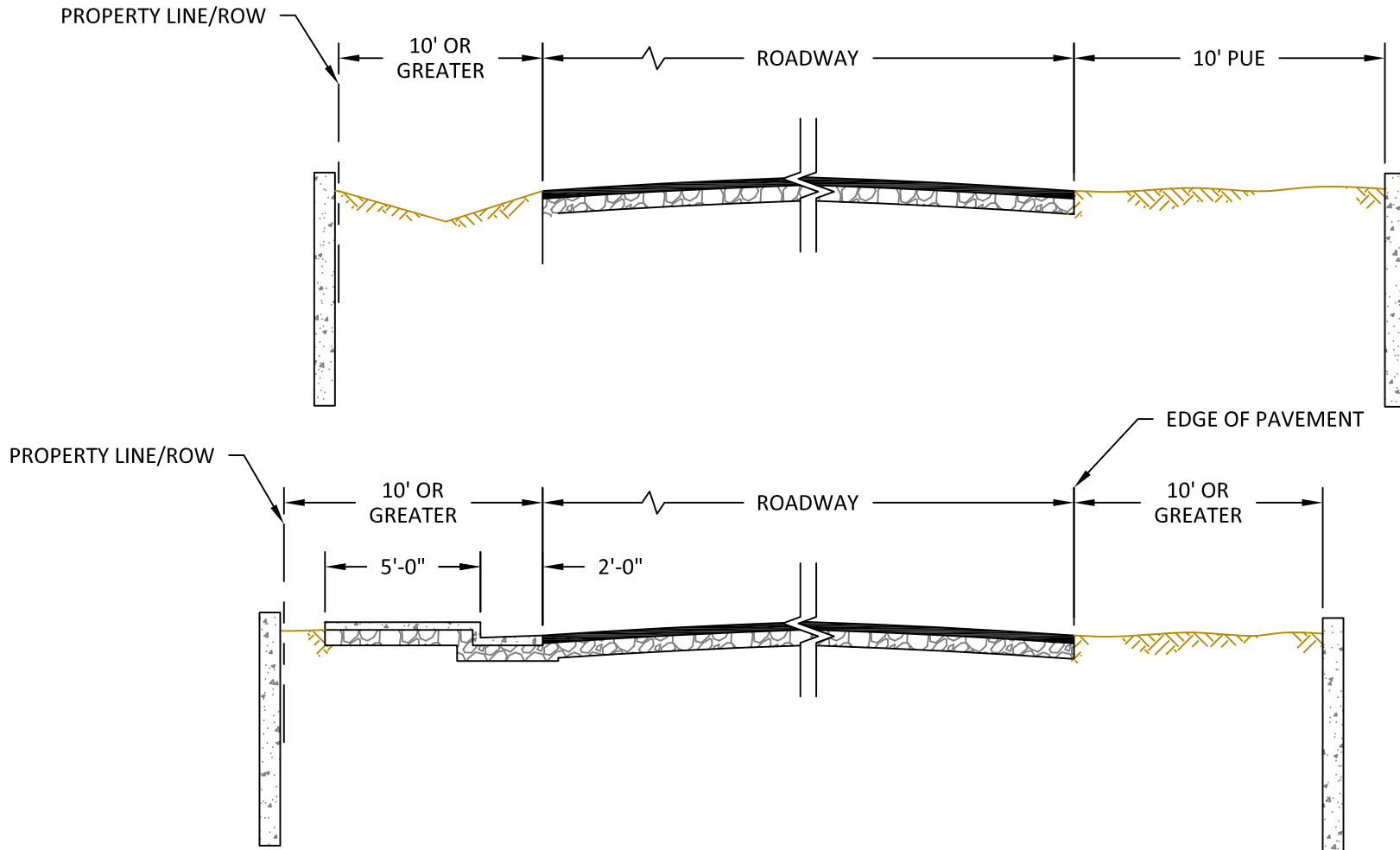

**HEADWALL SETBACKS  
ON ROAD CROSSINGS**

DATE: JUNE 2017

SCALE: NONE

STANDARD #:

CR 15

APPROVED BY:

*David B. Bakker*

DAVID B. BAKKER, P.E.  
SENIOR CIVIL ENGINEER

4/29/22

DATE

REV	CHANGE	DATE	BY
1	RELEASE	06/17	LH
2			
3			
4			

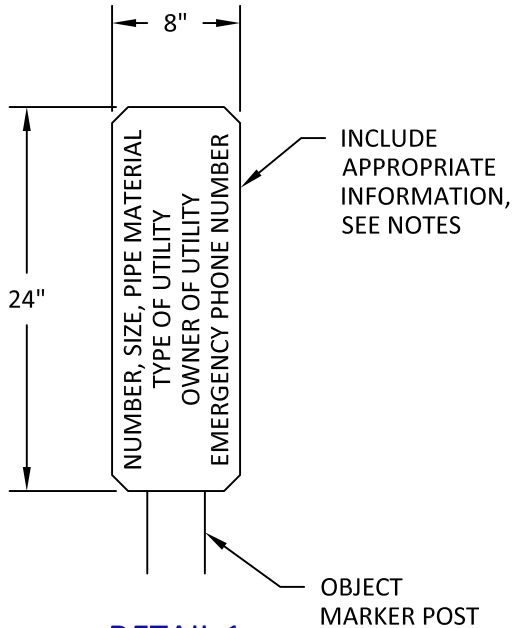

NOTES:

1. IRRIGATION UTILITY MARKER AND POST SHALL BE PLACED 12 INCHES INSIDE OF M.I.D. RIGHT OF WAY.
2. UTILITY MARKER POSTS SHALL BE STANDARD 6 FOOT GALVANIZED OBJECT MARKER POSTS WITH 8 INCH X 24 INCH TYPE "A" OBJECT MARKER BOLTED TO OBJECT MARKER POST IN MINIMUM 2 LOCATIONS.
3. UTILITY MARKER SHALL SHOW THE FOLLOWING INFORMATION: NUMBER OF PIPES, PIPE SIZES, PIPE MATERIAL, TYPE OF UTILITY, OWNER OF UTILITY, AND EMERGENCY PHONE NUMBER. INFORMATION SHALL BE PERMANENTLY ATTACHED TO THE MARKER BY SILKSCREENING, ENGRAVING, OR OTHER SUITABLE METHOD, AS PRE-APPROVED BY M.I.D. ENGINEER. EMERGENCY NOTIFICATION TELEPHONE NUMBER 911 IS NOT ACCEPTABLE.

DETAIL 1

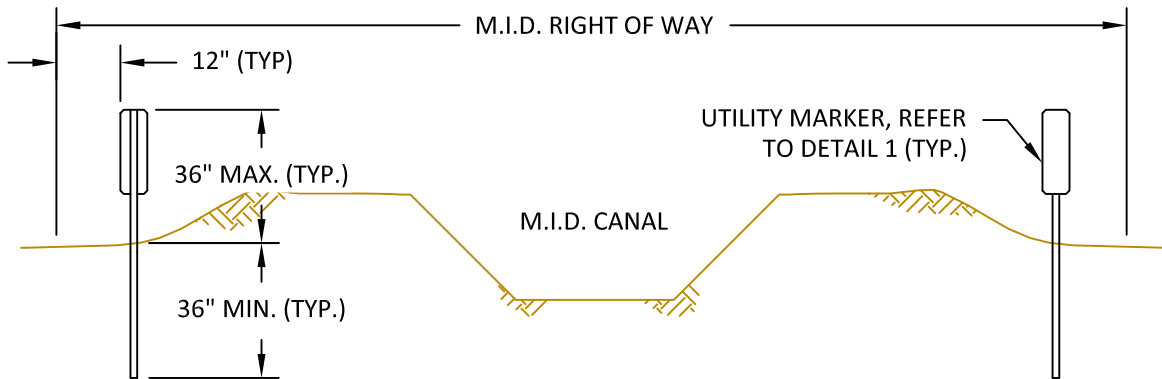

M.I.D. CANAL UTILITY MARKER LOCATION

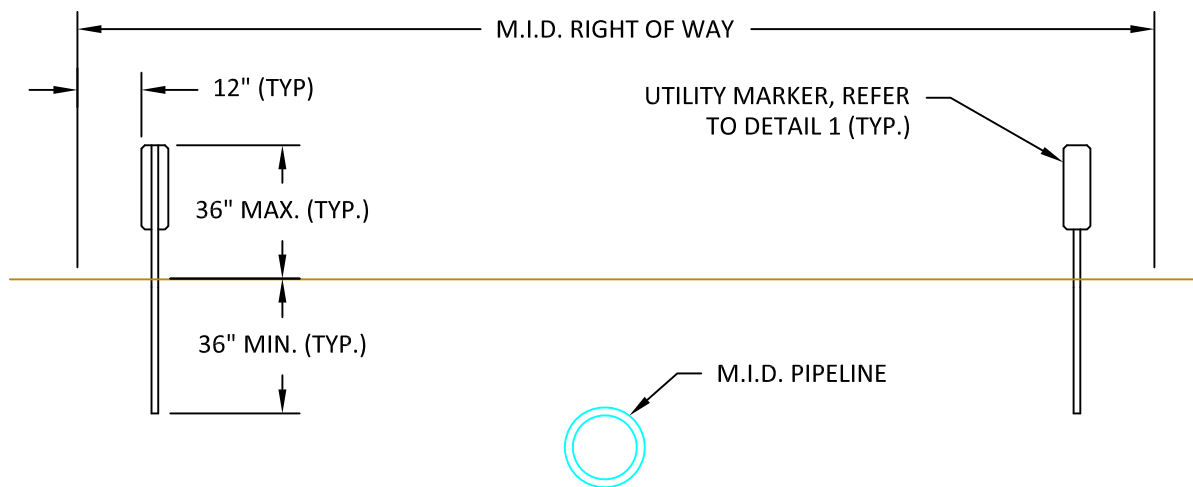

M.I.D. PIPELINE UTILITY MARKER LOCATION



UTILITY CROSSING MARKER

DATE: JUNE 2017

STANDARD #:

CR 20

SCALE: NONE

APPROVED BY:

CHAD J. TIENKEN, P.E., P.L.S.  
CIVIL ENGINEERING MANAGER

DATE: 9/7/17

**NOTES:**

1. CONCRETE STRENGTH TO BE 3,000 PSI @ 28 DAYS. NO ADMIXTURES SHALL BE INCORPORATED INTO CONCRETE MIX UNLESS PRE-APPROVED BY M.I.D. SEE M.I.D. STANDARD G 04 - CONCRETE NOTES\*.
2. THIS DETAIL IS NOT TO BE USED AS AN ALTERNATIVE TO PIPELINE REPLACEMENT.
3. THIS DETAIL IS ONLY TO BE USED WHEN PRE-APPROVED BY M.I.D. ENGINEER.

REV	CHANGE	DATE	BY
1	RELEASE	04/22	LH
2			
3			
4			

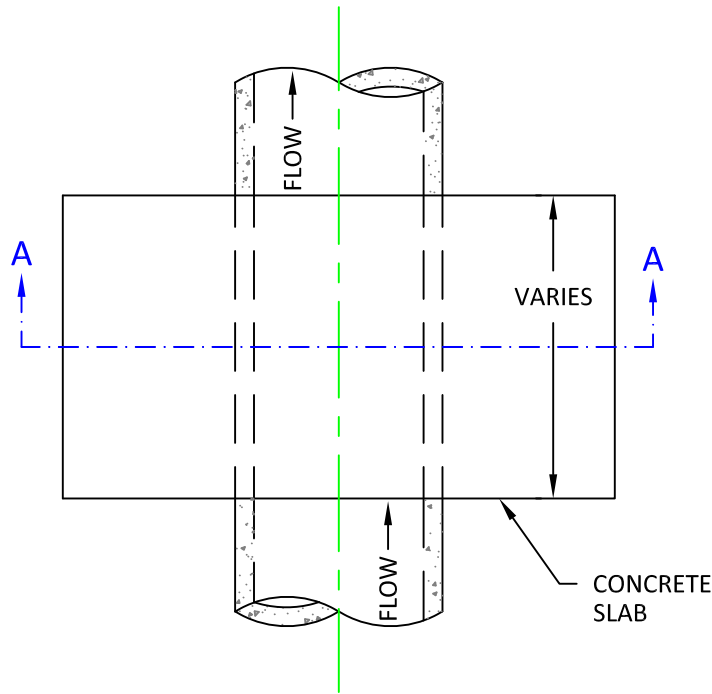

**PLAN VIEW**

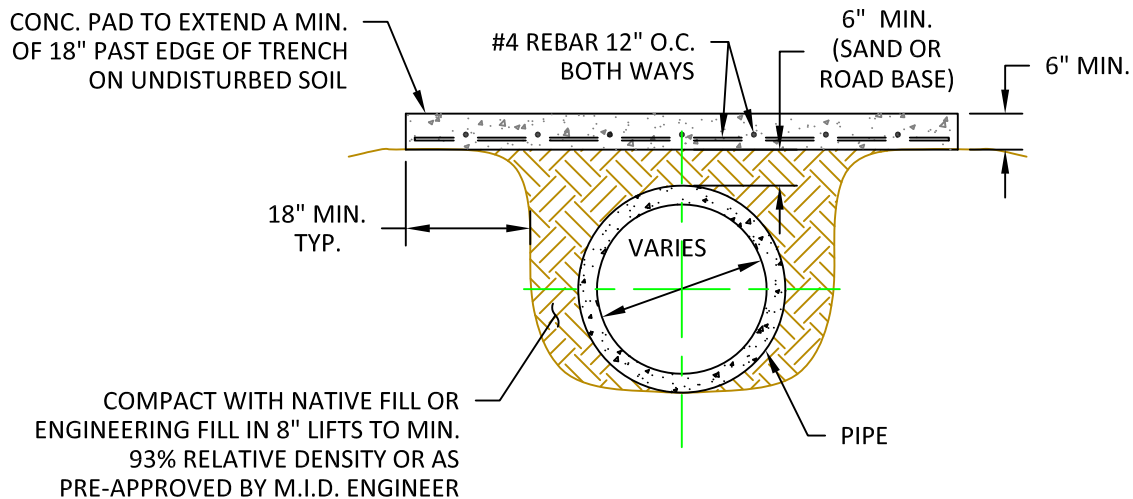

**SECTION A-A**

\*REFERENCED STANDARD(S): G 04



**DRIVEWAY SLAB  
FOR PIPELINE**

DATE: APRIL 2022

STANDARD #:

M 05

SCALE: NONE

APPROVED BY:

*David B. Bakker*

DAVID B. BAKKER, P.E.  
SENIOR CIVIL ENGINEER

DATE: 4/29/22

**NOTE:**

1. CANAL GATE TO BE WATERMAN C-10 CANAL GATE OR PRE-APPROVED EQUIVALENT WITH GALVANIZED FRAME.
2. THIS STANDARD MAY BE USED FOR A MAXIMUM SPAN OF 5'-0". FOR SPANS GREATER THAN 5'-0" SEE M.I.D. STANDARD M 47 - STRUCTURE GRATING\*.

REV	CHANGE	DATE	BY
1	RELEASE	06/17	LH
2	REVISED	04/22	LH
3			
4			

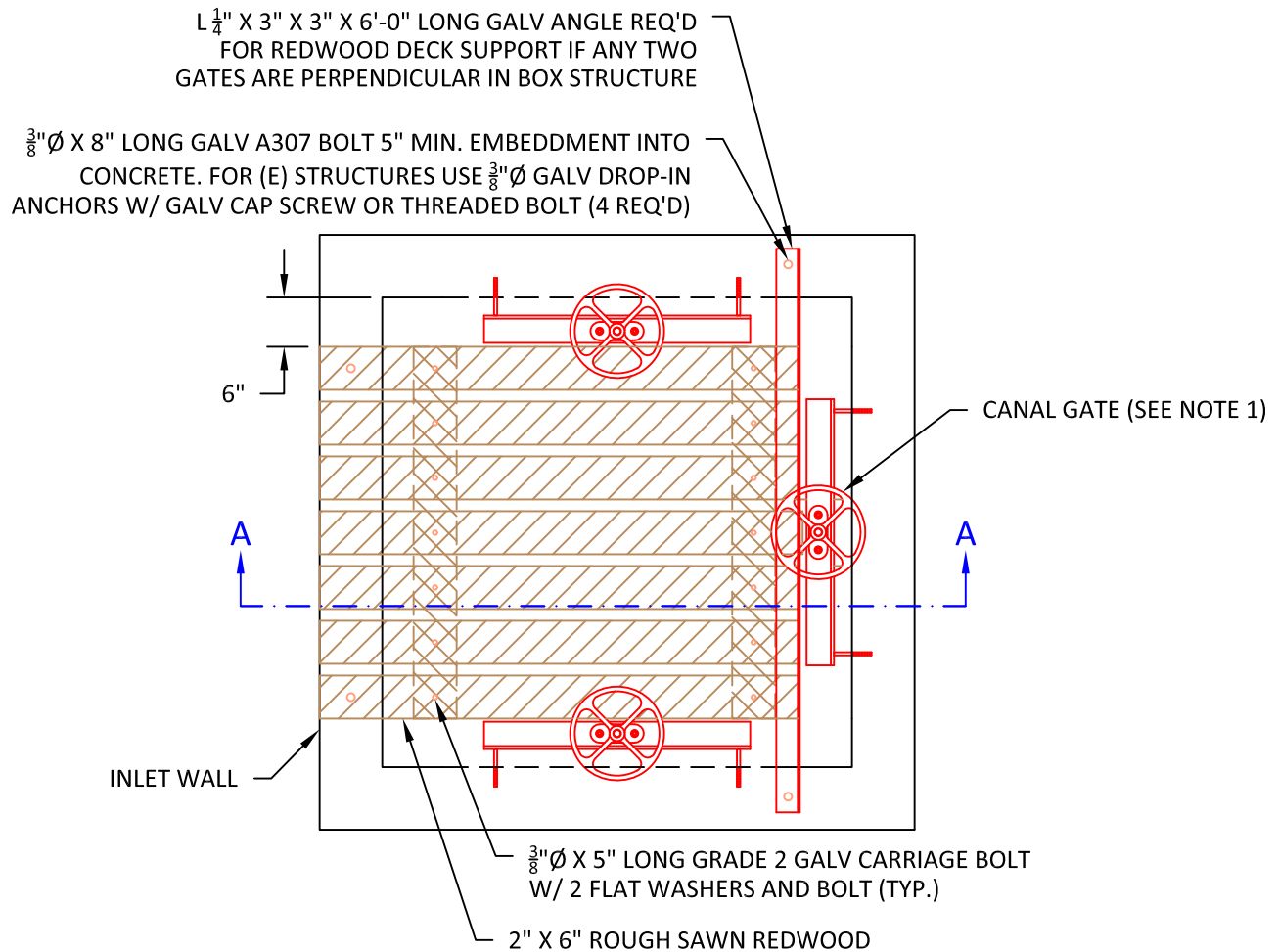

**PLAN VIEW**

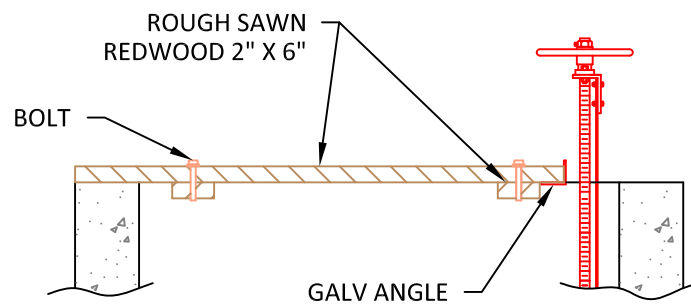

**SECTION A-A**

\*REFERENCED STANDARD(S): M 47



**STANDARD REDWOOD DECK DETAIL**

DATE: JUNE 2017

STANDARD #:

M 10

SCALE: NONE

APPROVED BY:

*David B. Bakker*

DAVID B. BAKKER, P.E.  
SENIOR CIVIL ENGINEER

DATE: 4/29/22

REV	CHANGE	DATE	BY
1	RELEASE	06/17	LH
2	REVISED	04/22	LH
3			
4			

**NOTES:**

- GATES: 12', 14' OR 16' X 52" POWDER RIVER "CLASSIC HEAVY DUTY GATE" WITH GATE SUPPORT AND GATE STOP, OR PRE-APPROVED EQUIVALENT. GATE OPENING VARIES BY LOCATION. REFLECTIVE TAPE TO BE PLACED ON TWO HORIZONTAL GATE MEMBERS.
- VERTICAL POSTS: 3" X 3" X 3/16" SQUARE TUBING .
- HORIZONTAL POSTS: 1-1/2" X 1-1/2" X 3/32" SQUARE TUBING .
- LOCATION: TYPICAL GATE INSTALLATION WILL BE SET BACK APPROXIMATELY 50' FROM CURB OR ROAD RIGHT-OF-WAY.
- SIGNS: SIGNS WILL BE INSTALLED ON A STEEL POST AND LOCATED 8' BEHIND GATE (OTHER LOCATIONS AS APPLICABLE).
- LOCKS: LOCKS SHALL BE M.I.D. D-219 PADLOCKS (PRIVATE LOCKS MAY BE AUTHORIZED).

\*FOR HIGH SECURITY LOCATIONS CONSULT M.I.D. ENGINEER.

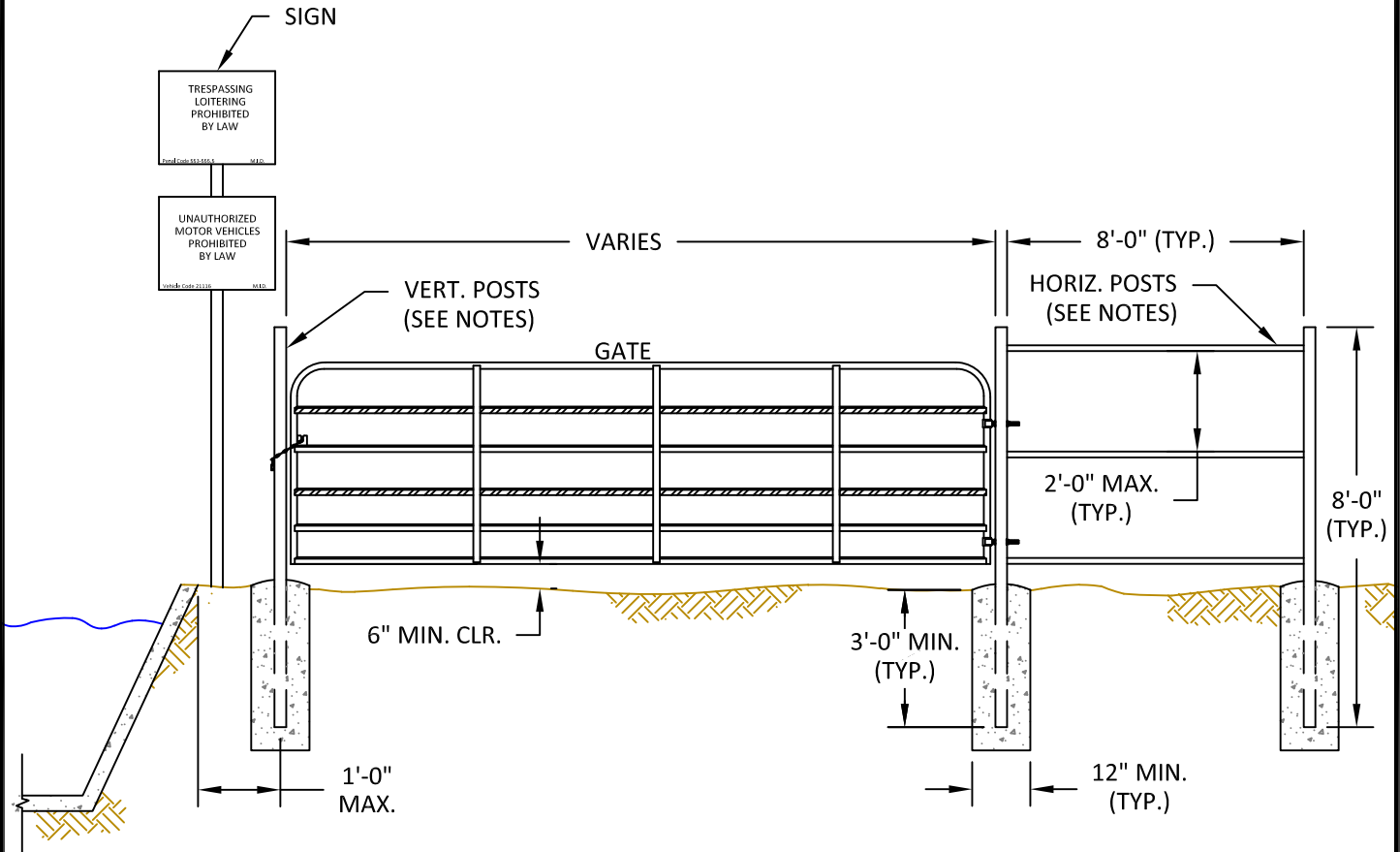

**ELEVATION VIEW**



TYPICAL M.I.D. CANAL ROADWAY GATE DETAIL

DATE: JUNE 2017

STANDARD #:

M 15

SCALE: NONE

APPROVED BY:

*David B. Bakker*

DAVID B. BAKKER, P.E.  
SENIOR CIVIL ENGINEER

DATE: 4/29/22

**NOTES:**

1. H-BRACE UNITS SHALL BE INSTALLED PRIOR TO CUTTING EXISTING FENCE.
2. HEIGHT OF POSTS TO MATCH EXISTING POSTS.
3. NUMBER OF STRANDS TO MATCH EXISTING FENCE, 5 STRAND MINIMUM.
4. FENCE HEIGHT TO BE DETERMINED BY LANDOWNER (4'-6" TO 5'-0")
5. MINIMUM 6" DIAMETER PRESSURE TREATED POST.

REV	CHANGE	DATE	BY
1	RELEASE	06/17	LH
2	REVISED	04/22	LH
3			
4			

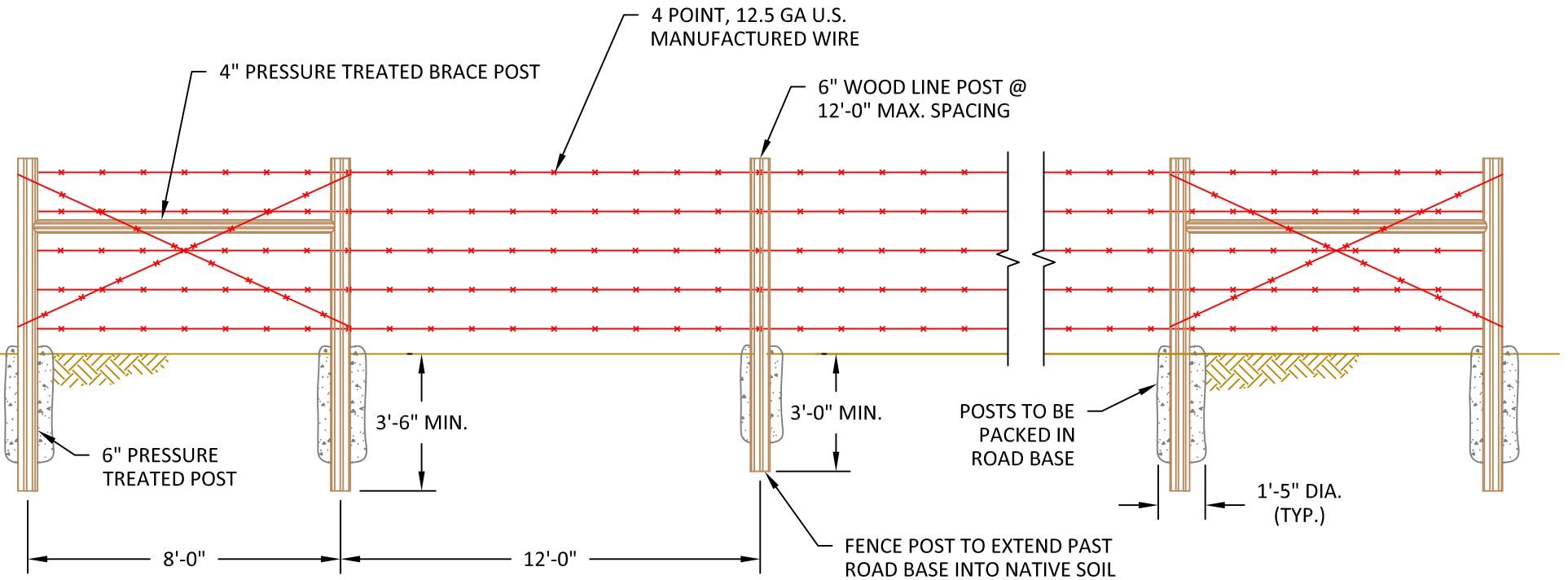

**BARBED WIRE FENCE DETAIL**



DATE: JUNE 2017  
SCALE: NONE

STANDARD #:  
M 20

APPROVED BY:

*David B. Bakker*

DAVID B. BAKKER, P.E.  
SENIOR CIVIL ENGINEER

4/29/22  
DATE

REV	CHANGE	DATE	BY
1	RELEASE	06/17	LH
2	REVISED	04/22	LH
3			
4			

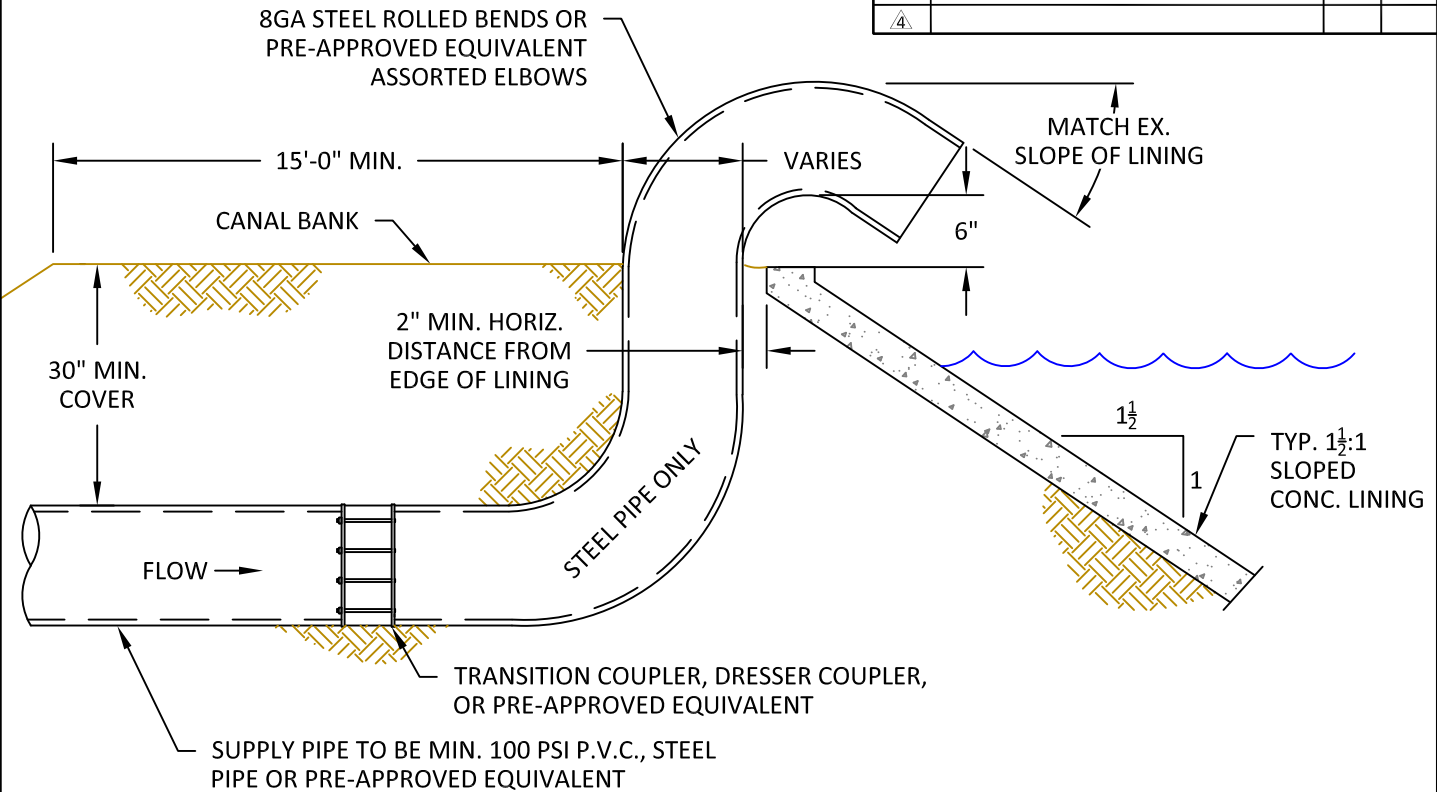

**OPTION 1**

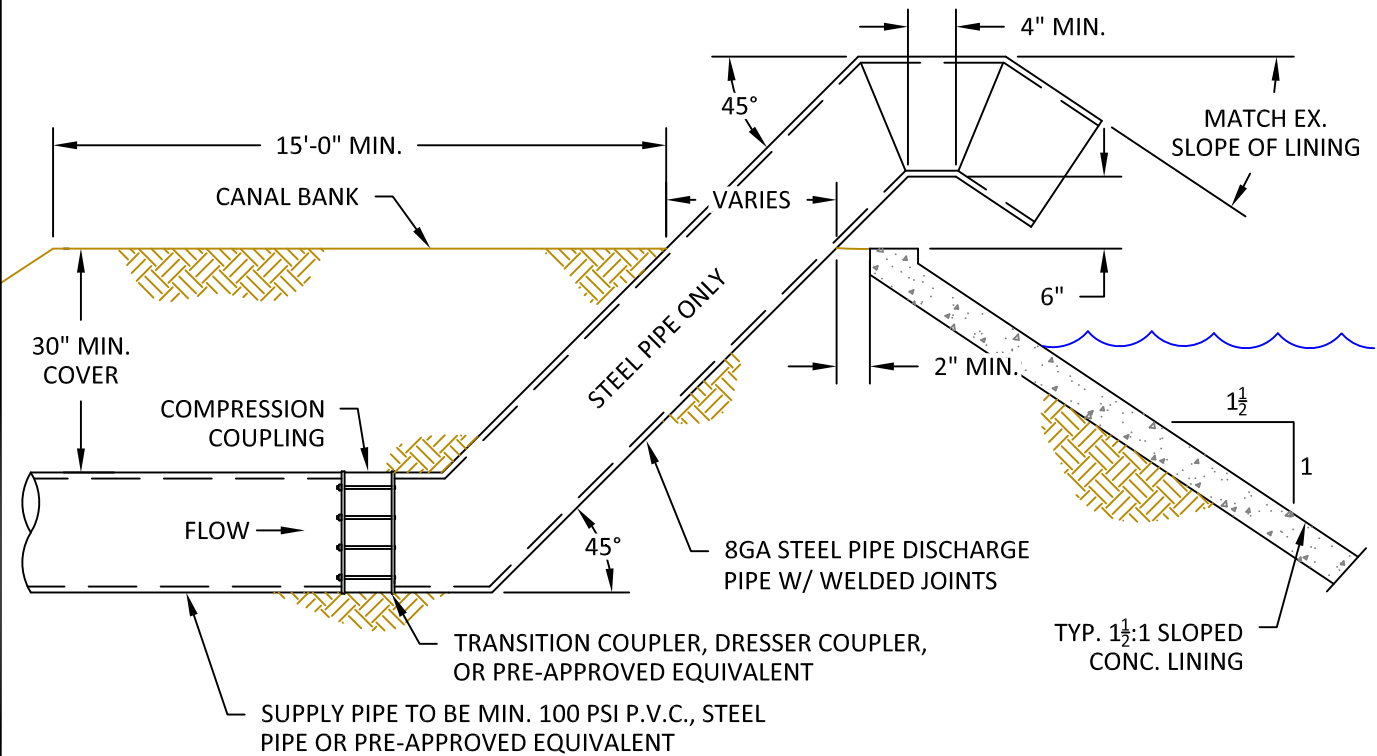

**OPTION 2**



**TYPICAL DISCHARGE LINE DETAILS**

DATE: JUNE 2017	STANDARD #: M 25
SCALE: NONE	

APPROVED BY:  
*David B. Bakker*  
 DAVID B. BAKKER, P.E.  
 SENIOR CIVIL ENGINEER  
 DATE: 4/29/22



REV	CHANGE	DATE	BY
1	RELEASE	06/17	LH
2	REVISED	04/22	LH
3			
4			

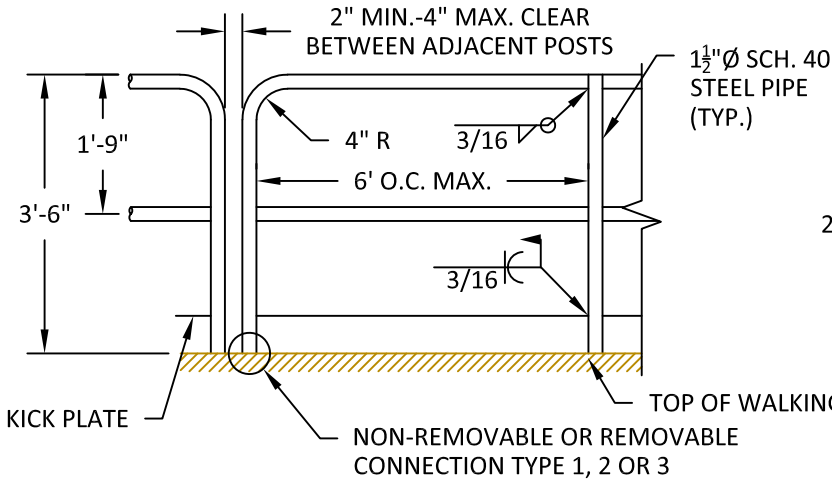

TYPICAL HANDRAILING DETAIL

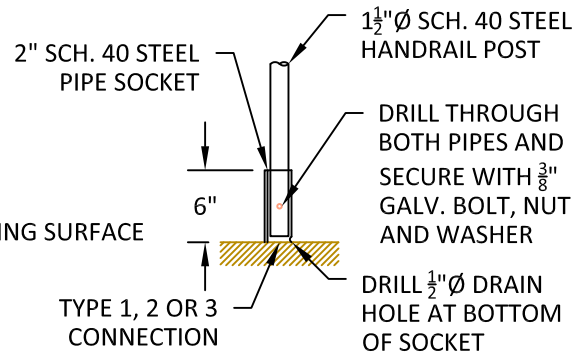

REMOVABLE HANDRAIL POST

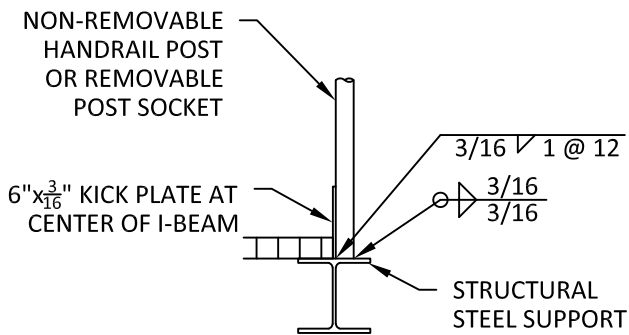

TYPE 1 - WELDED CONNECTION

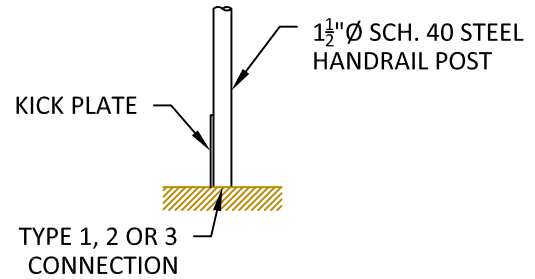

NON-REMOVABLE HANDRAIL POST

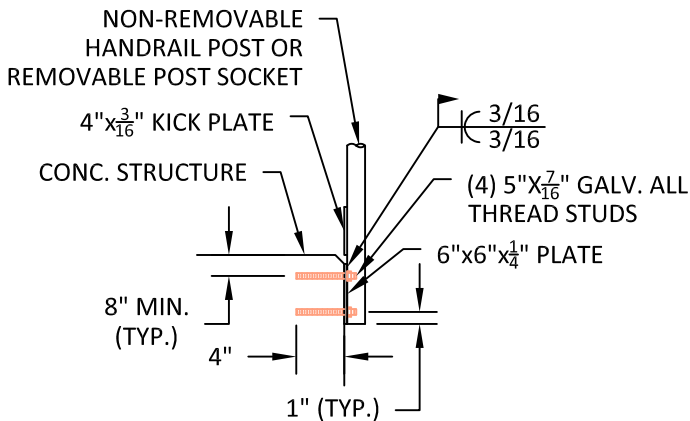

TYPE 2 - SIDE BOLTED CONNECTION

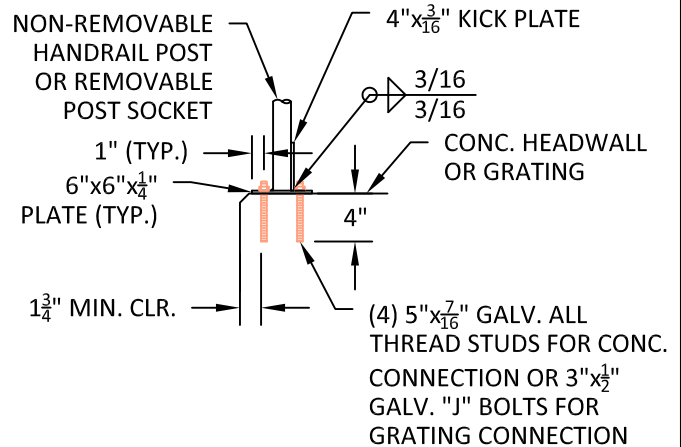

TYPE 3 - BOLTED CONNECTION

NOTE: A LARGER PLATE MAY BE USED TO MOUNT ADJACENT POSTS/SOCKETS TO SAME PLATE

NOTES:

1. ALL HANDRAILING SHALL BE EITHER HOT-DIP GALVANIZED STEEL, OR ALUMINUM. IF ALUMINUM IS USED, ALL HARDWARE SHALL BE STAINLESS STEEL.
2. IF HOT DIP GALVANIZED. ALL VENT HOLES SHALL BE PLUGGED WITH RUBBER GROMMETS FOLLOWING GALVANIZING.
3. REMOVABLE HANDRAILING PANELS SHALL HAVE A MAX TOTAL LENGTH OF 12' PER PANEL.



STRUCTURE HANDRAILING

DATE: JUNE 2017

STANDARD #:

M 45

SCALE: NONE

APPROVED BY:

*David B. Bahner*

DAVID B. BAKKER, P.E.  
SENIOR CIVIL ENGINEER

DATE: 4/29/22

REV	CHANGE	DATE	BY
1	RELEASE	06/17	LH
2	REVISED	04/22	LH
3			
4			

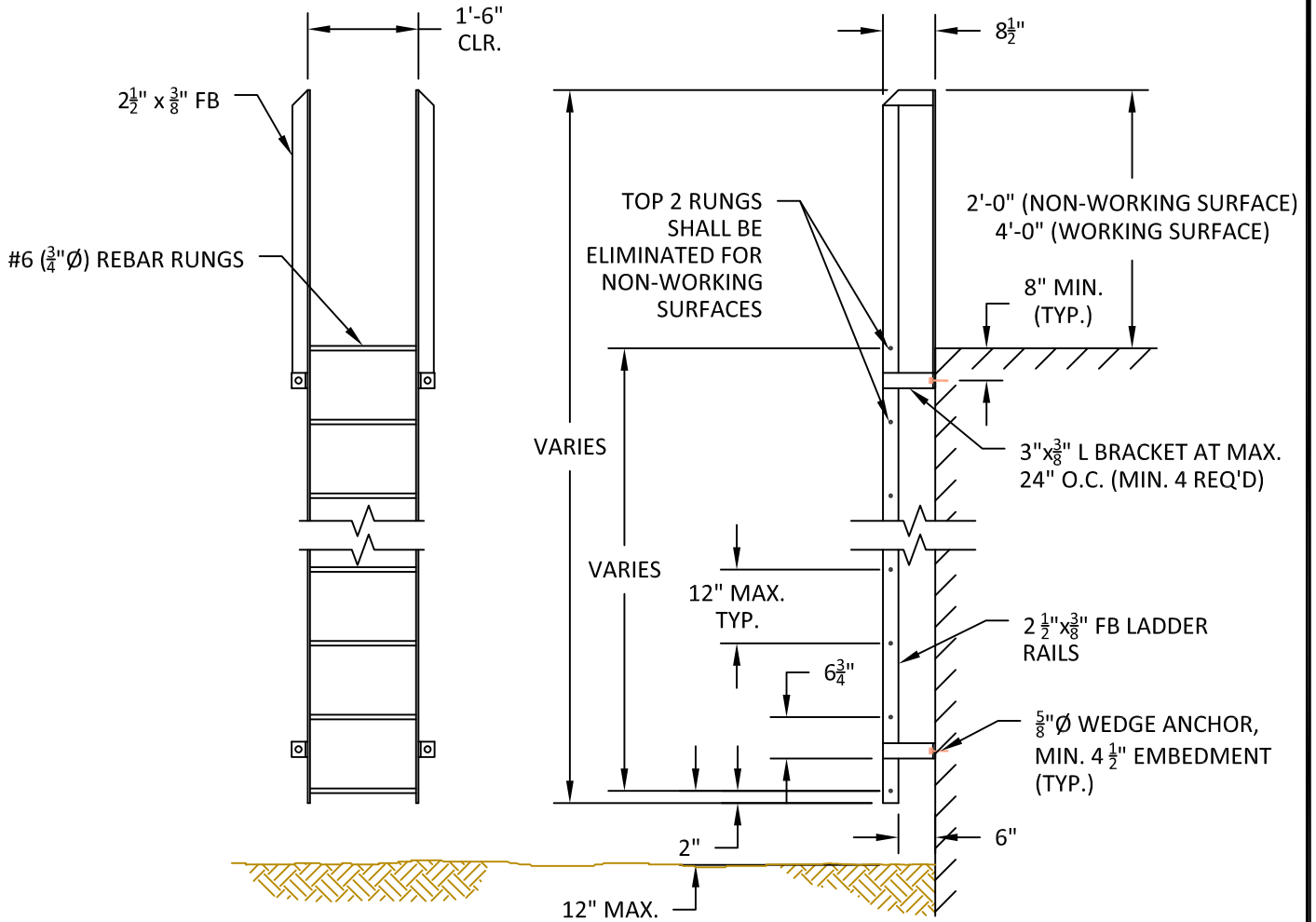

**NOTES:**

1. ALL METAL SURFACES TO BE HOT DIP GALVANIZED OR BRUSH PAINTED WITH ONE COAT RED RUSTOLEUM PRIMER, SECOND COAT GREEN RUSTOLEUM, FINAL COAT SAND OR TAN EXTERIOR GLOSS FINISH OR PRE-APPROVED EQUIVALENT.
2. ALL FLAT BAR CONNECTIONS SHALL BE WELDED. LADDER RUNGS SHALL BE WELDED TO FLAT BAR. WELDS SHALL BE GROUND SMOOTH AND WIRE BRUSHED CLEAN. ALL WELDS TO BE 1/4 INCH CONTINUOUS FILLET.
3. ATTACH TO CONCRETE STRUCTURE WITH 5/8 INCH DIAMETER WEDGE ANCHORS (TYP) PER MANUFACTURER SPECIFICATIONS. MIN 4-1/2 INCHES EMBEDMENT.
4. MUST CONFORM TO CAL/OSHA STANDARDS, REFER TO CAL/OSHA SPECIFICATIONS FOR ELEVATED PLATFORMS.
5. IF TOP OF STRUCTURE IS 7.5 FEET OR MORE ABOVE SURROUNDING GRADE, HANDRAILING SHALL BE REQUIRED. REFER TO M.I.D. DETAIL M 45, STRUCTURE HANDRAILING\*.

\*REFERENCED STANDARD(S): M 45



**STRUCTURE LADDER**

DATE: JUNE 2017

STANDARD #:

M 46

SCALE: NONE

APPROVED BY:

*David B. Bakker*

DAVID B. BAKKER, P.E.  
SENIOR CIVIL ENGINEER

DATE: 4/29/22

REV	CHANGE	DATE	BY
1	RELEASE	06/17	LH
2	REVISED	04/22	LH
3			
4			

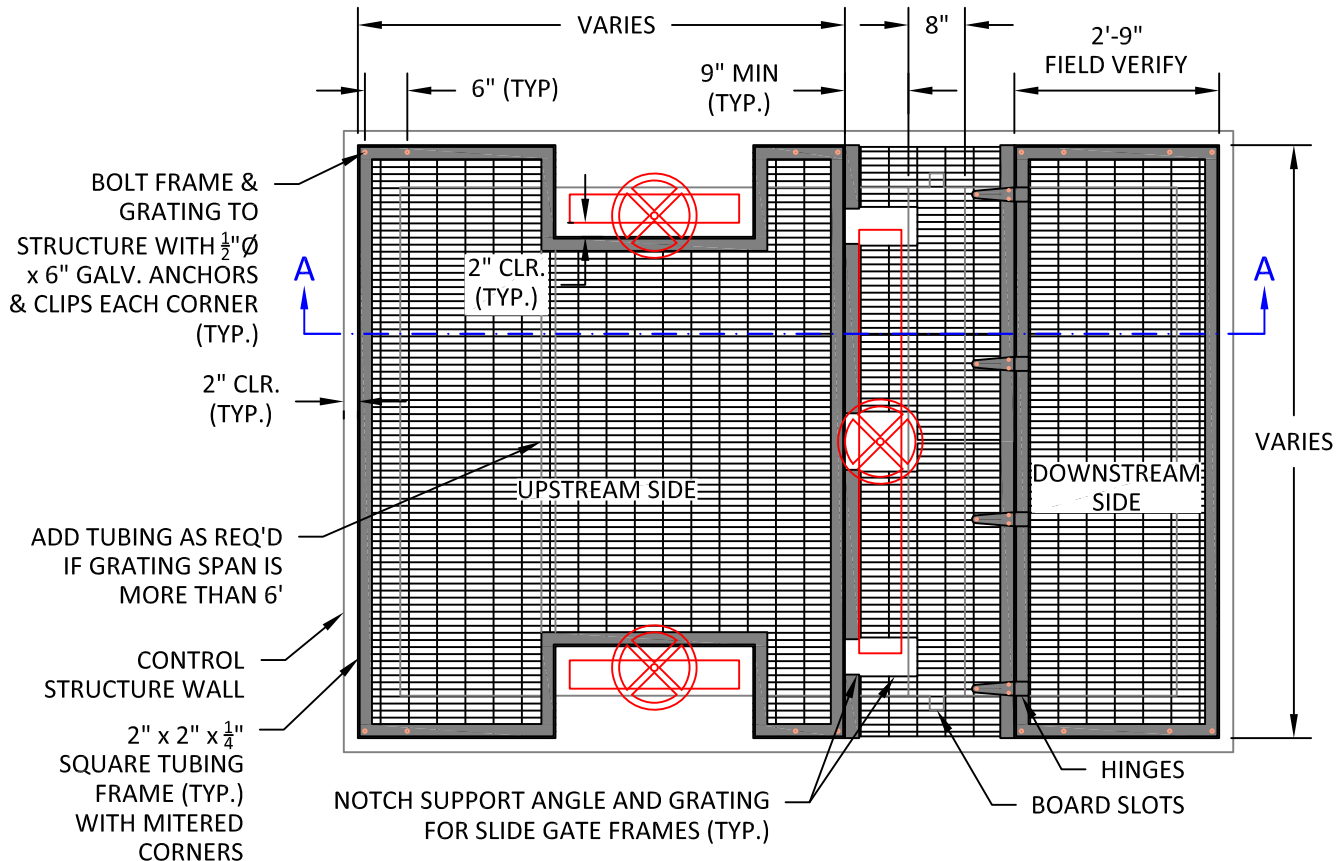

**PLAN VIEW**

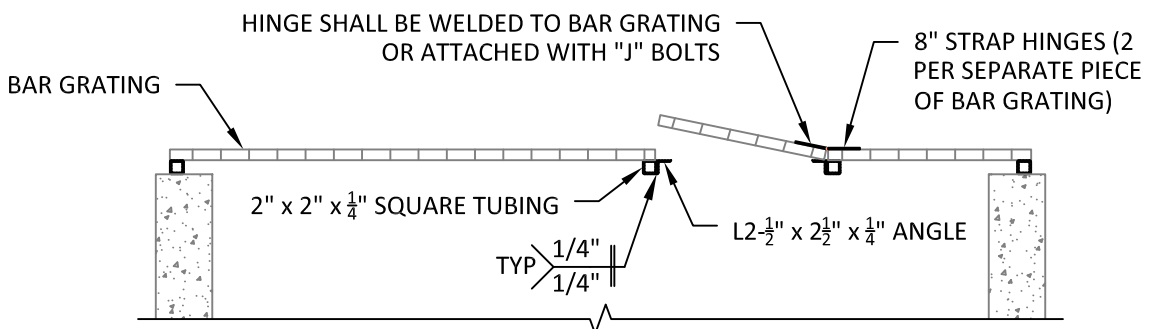

**SECTION A-A**

**NOTES:**

1. BAR GRATING SHALL BE MCNICHOLS GW-175  $1\frac{3}{4}$ " X  $\frac{3}{16}$ " GALVANIZED STEEL BARS SPACED AT  $1\frac{3}{16}$ " CENTERS WITH CROSS BARS AT 4" CENTERS, OR PRE-APPROVED EQUIVALENT. MAXIMUM SPAN SHALL BE 6'. GRATING SHALL BE BANDED ALL AROUND INCLUDING NOTCHED AREAS.
2. UNLESS OTHERWISE NOTED, ALL STEEL SURFACES SHALL BE HOT DIP GALVANIZED OR BRUSH PAINTED WITH ONE COAT RE RUSTOLEUM PRIMER, SECOND COAT GREEN RUSTOLEUM. FINAL COAT SAND OR TAN EXTERIOR GLOSS FINISH, OR PRE-APPROVED EQUIVALENT.
3. PROVIDE REMOVABLE (BOLTED DOWN) GRATING SECTIONS ON UPSTREAM SIDE OF CONTROL STRUCTURE (MAXIMUM 2' WIDTH EACH)



STRUCTURE GRATING	
DATE: JUNE 2017	STANDARD #: M 47
SCALE: NONE	

APPROVED BY:  
*David B. Bakker*  
 DAVID B. BAKKER, P.E.  
 SENIOR CIVIL ENGINEER  
 DATE: 4/29/22

**NOTES:**

1. ALL STEEL MEMBERS AND MATERIALS SHALL BE A-36 GALVANIZED AND SHALL BE CONSTRUCTED WITH STAINLESS STEEL BOLTS, NUTS AND WASHERS
2. WHEN GRATING IS TO BE FABRICATED IN PARTS AND SPLICED AT THE WORK SITE, GALVANIZED PAINT IS TO BE APPLIED ON ALL WELDS.

REV	CHANGE	DATE	BY
1	RELEASE	06/17	LH
2			
3			
4			

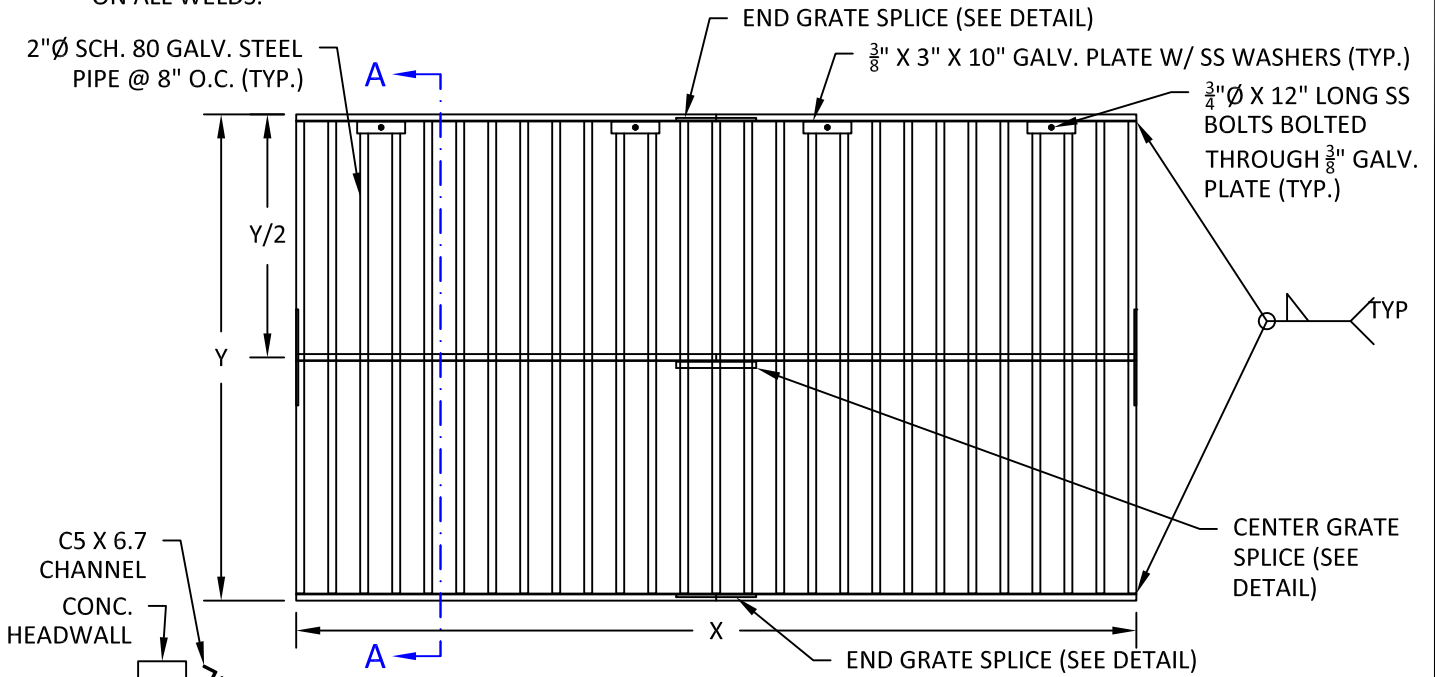

**PLAN VIEW**

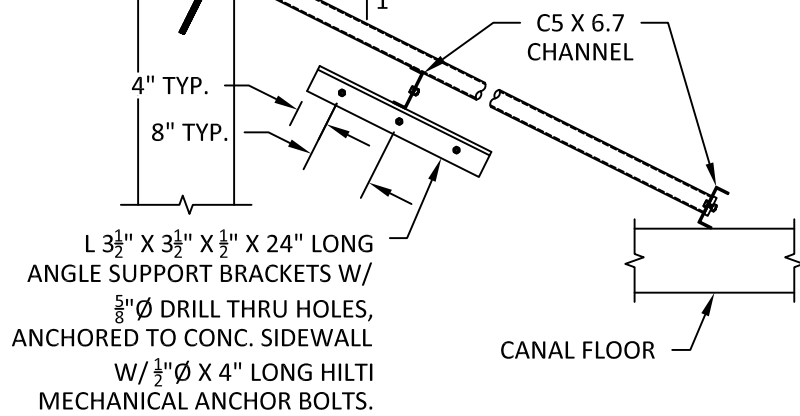

**SECTION A-A**

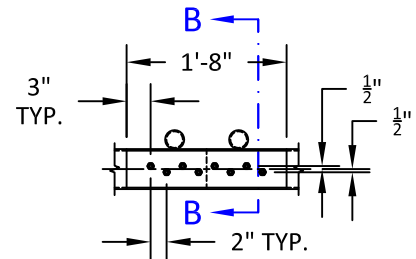

**CENTER GRATE SPLICE**

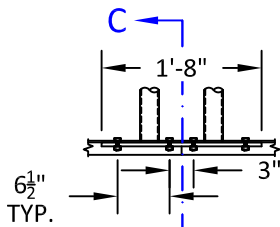

**END GRATE SPLICE**

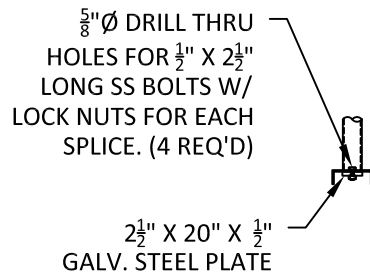

**SECTION C-C**

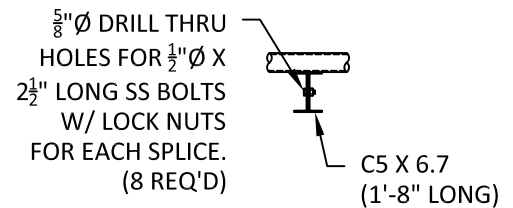

**SECTION B-B**



**INLET GRATE**

DATE: JUNE 2017

STANDARD #:

M 50

SCALE: NONE

APPROVED BY:

CHAD J. TIENKEN, P.E., P.L.S.  
CIVIL ENGINEERING MANAGER

DATE: 9/7/17

**NOTES:**

1. PRIVATE IRRIGATION BACKFLUSH FILTER DISCHARGE TO BE LOCATED UPSTREAM OF ALL CHEMICAL INJECTION SYSTEMS AND MUST BE FREE OF ANY CHEMICALS OR FERTILIZERS. IF BACKFLUSH WATER DOES NOT MEET M.I.D. WATER QUALITY STANDARDS THE BACKFLUSH LINE MAY BE REMOVED AND TERMINATED BY M.I.D.
2. COMPACT NATIVE FILL IN 8" LOOSE LIFTS TO MIN. 90% RELATIVE DENSITY OR AS DIRECTED BY M.I.D. ENGINEER.

REV	CHANGE	DATE	BY
1	RELEASE	06/17	LH
2	REVISION	04/22	LH
3			
4			

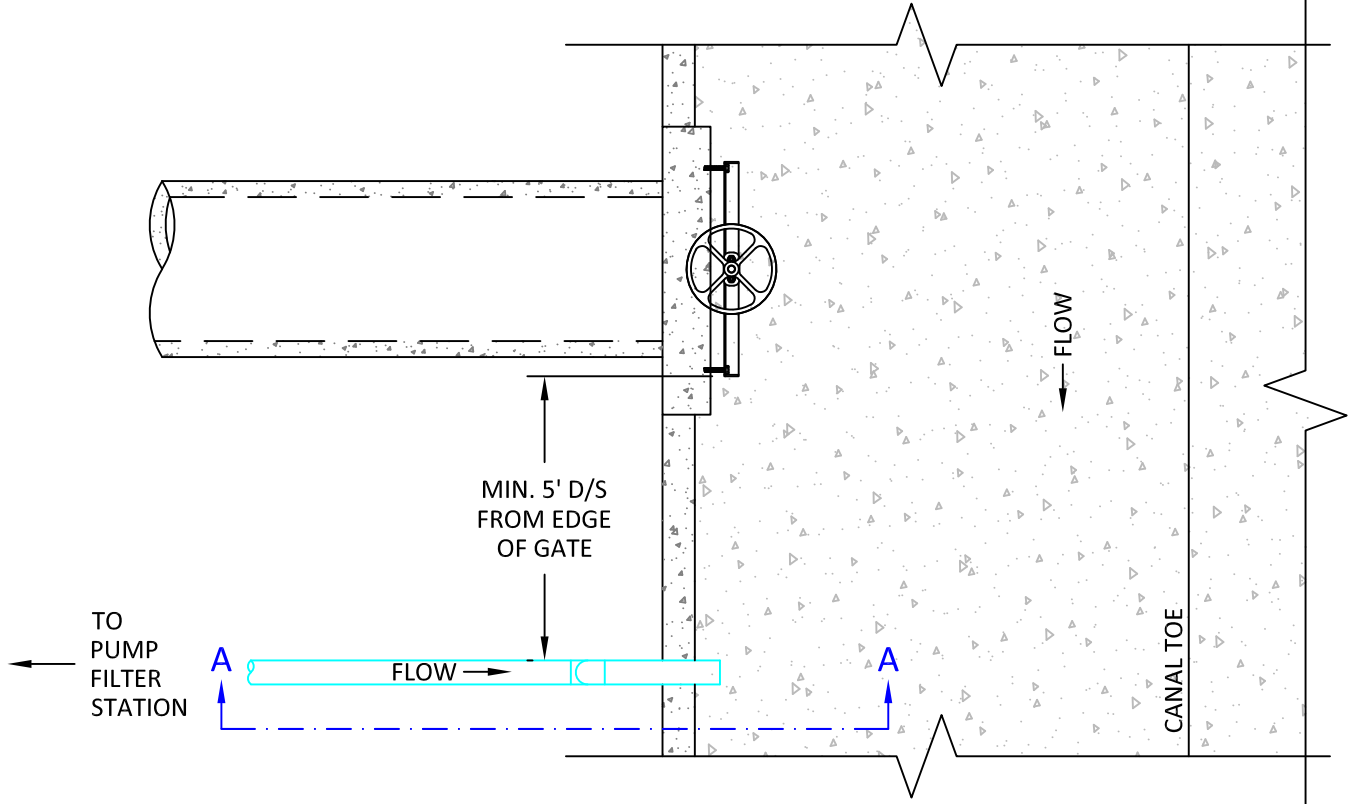

**PLAN VIEW**

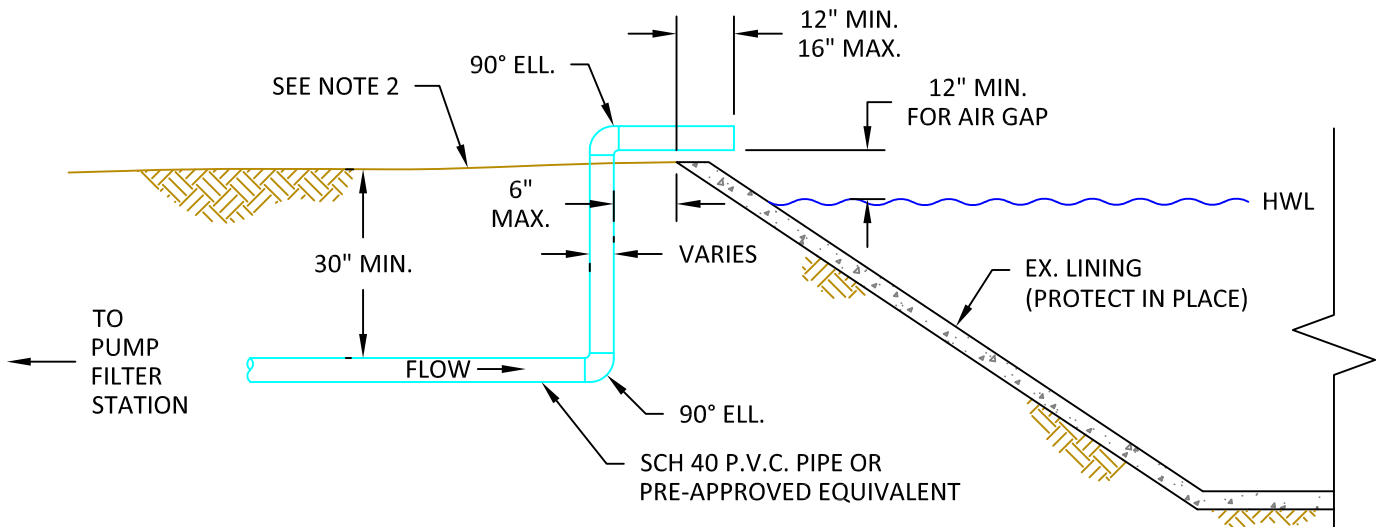

**SECTION A-A**



**PRIVATE IRRIGATION  
BACKFLUSH FILTER DISCHARGE**

DATE: JUNE 2017

STANDARD #:

M 55

SCALE: NONE

APPROVED BY:

*David B. Bakker*

DAVID B. BAKKER, P.E.  
SENIOR CIVIL ENGINEER

DATE: 4/29/22

**NOTES:**

1. PRIVATE IRRIGATION BACKFLUSH FILTER DISCHARGE TO BE LOCATED UPSTREAM OF ALL CHEMICAL INJECTION SYSTEMS AND MUST BE FREE OF ANY CHEMICALS OR FERTILIZERS. IF BACKFLUSH WATER DOES NOT MEET M.I.D. WATER QUALITY STANDARDS THE BACKFLUSH LINE MAY BE REMOVED AND TERMINATED BY M.I.D.
2. COMPACT NATIVE FILL IN 8" LOOSE LIFTS TO MIN. 90% RELATIVE DENSITY OR AS DIRECTED BY M.I.D. ENGINEER.

REV	CHANGE	DATE	BY
1	RELEASE	04/22	LH
2			
3			
4			

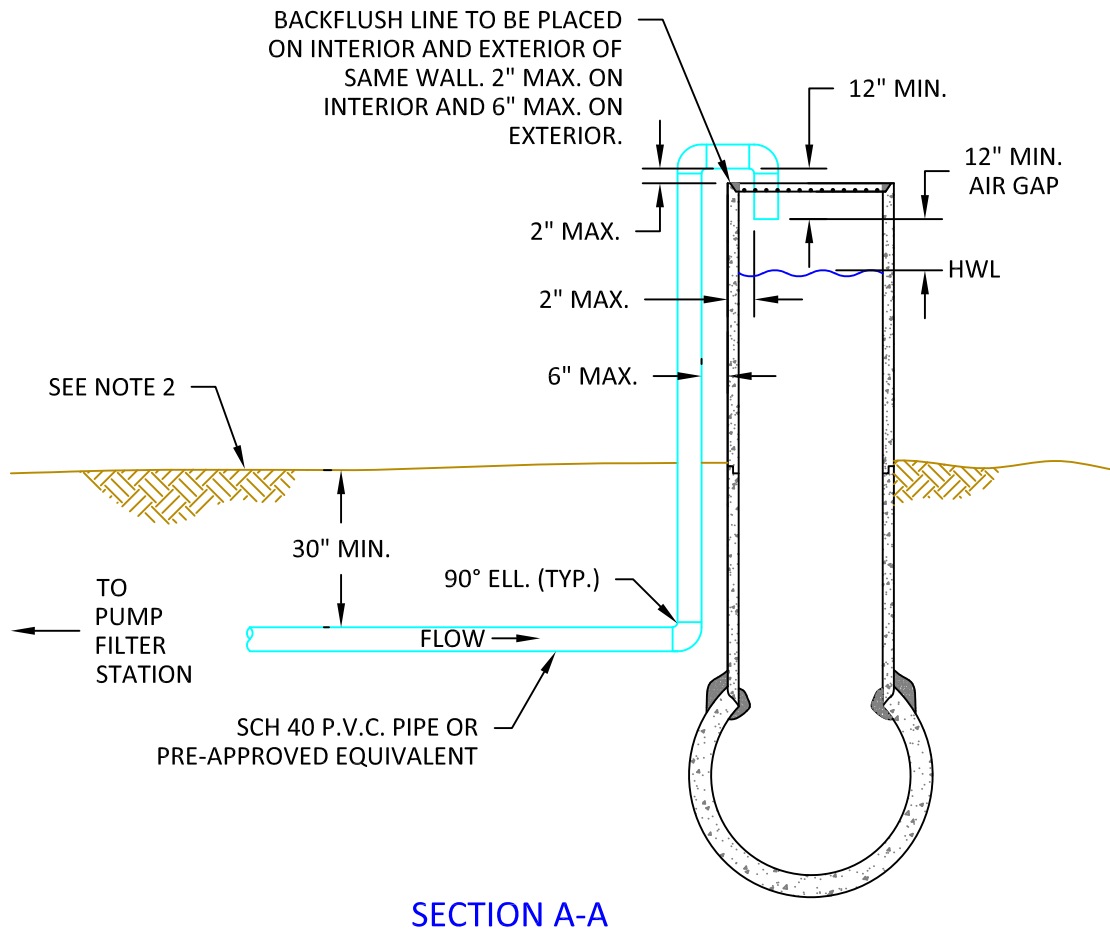
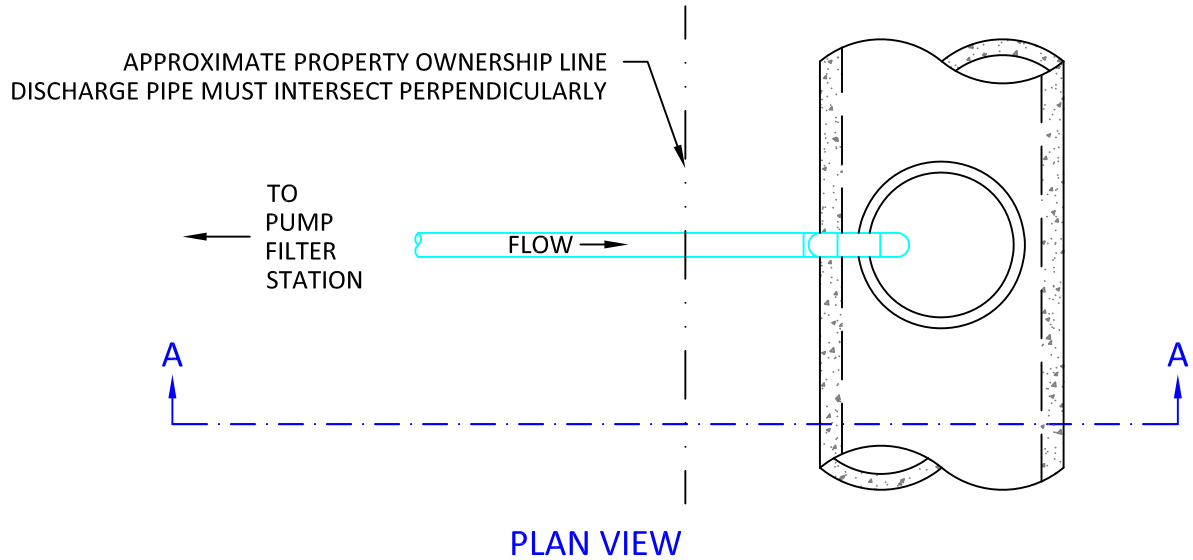

PRIVATE IRRIGATION BACKFLUSH FILTER DISCHARGE INTO STANDPIPE

DATE: APRIL 2022

STANDARD #:

M 56

SCALE: NONE

APPROVED BY:

*David B. Bakker*

DAVID B. BAKKER, P.E.  
SENIOR CIVIL ENGINEER

DATE: 4/29/22

**NOTES:**

1. PRIVATE IRRIGATION BACKFLUSH FILTER DISCHARGE TO BE LOCATED UPSTREAM OF ALL CHEMICAL INJECTION SYSTEMS AND MUST BE FREE OF ANY CHEMICALS OR FERTILIZERS. IF BACKFLUSH WATER DOES NOT MEET M.I.D. WATER QUALITY STANDARDS THE BACKFLUSH LINE MAY BE REMOVED AND TERMINATED BY M.I.D.
2. COMPACT NATIVE FILL IN 8" LOOSE LIFTS TO MIN. 90% RELATIVE DENSITY OR AS DIRECTED BY M.I.D. ENGINEER.

REV	CHANGE	DATE	BY
1	RELEASE	04/22	LH
2			
3			
4			

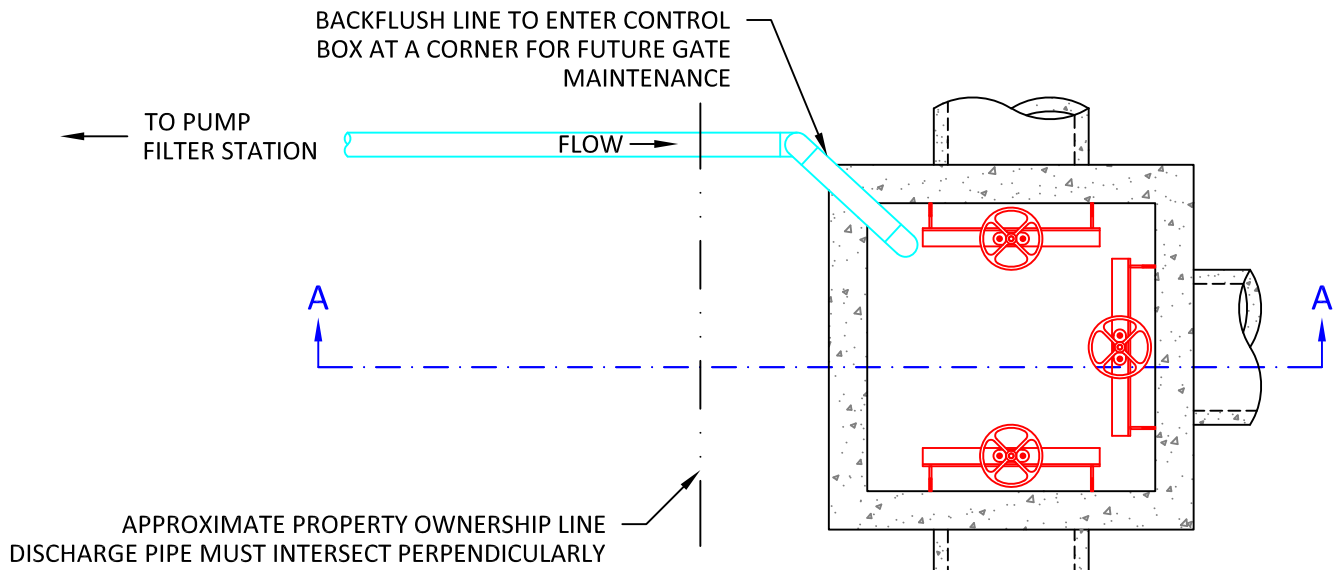

**PLAN VIEW**

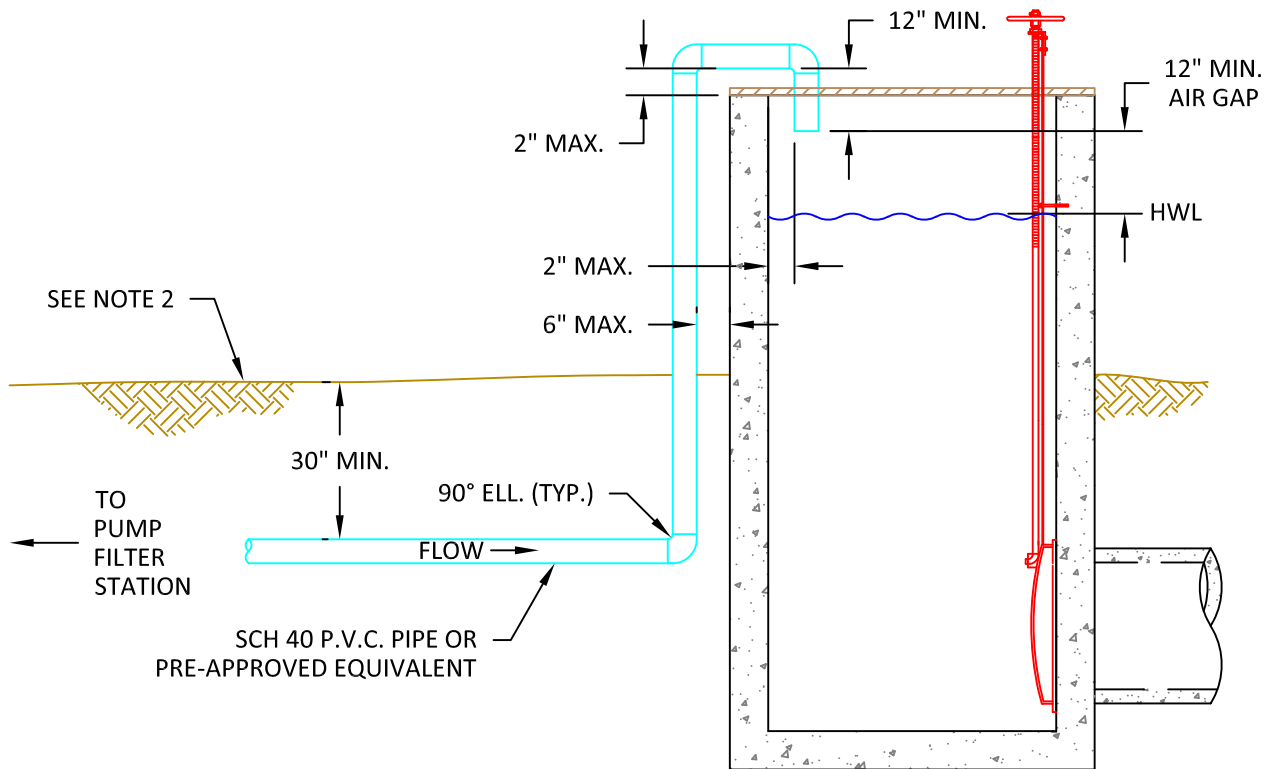

**SECTION A-A**



PRIVATE IRRIGATION BACKFLUSH  
 FILTER DISCHARGE INTO CONTROL BOX

DATE: APRIL 2022	STANDARD #: M 57
SCALE: NONE	

APPROVED BY:  
*David B. Bakker*  
 DAVID B. BAKKER, P.E.  
 SENIOR CIVIL ENGINEER

DATE: 4/29/22

**NOTES:**

1. CONCRETE STRENGTH TO BE 3,000 PSI @ 28 DAYS. NO ADMIXTURES SHALL BE INCORPORATED INTO CONCRETE MIX UNLESS PRE-APPROVED BY M.I.D. SEE M.I.D. STANDARD G 04 - CONCRETE NOTES\*.
2. SAW CUT, THOROUGHLY BRUSH AWAY DEBRIS AND CLEAN EXISTING LINING PRIOR TO CONCRETE PLACEMENT.
3. PROPERLY SEAL ALL JOINTS AND PIPES BY MORTARING. USE SOFT BRISTLE BRUSH TO BLEND MORTAR AND CONCRETE TOGETHER. SEE M.I.D. STANDARD G 11 - M.I.D. MORTAR MIX NOTES\*.
4. WATERSTOP TO SURROUND ENTIRE CONNECTION TO EXISTING HEADWALL SHALL BE VOLCLAY WATERSTOP-RX 102 BENTONITE CLAY STRIP OR ADEKA ULTRASEAL KBA-1510FP WATERSTOP. SEE M.I.D. STANDARD G 12 - CONNECTION TO EXISTING STRUCTURE\*

REV	CHANGE	DATE	BY
1	RELEASE	06/17	LH
2			
3			
4			

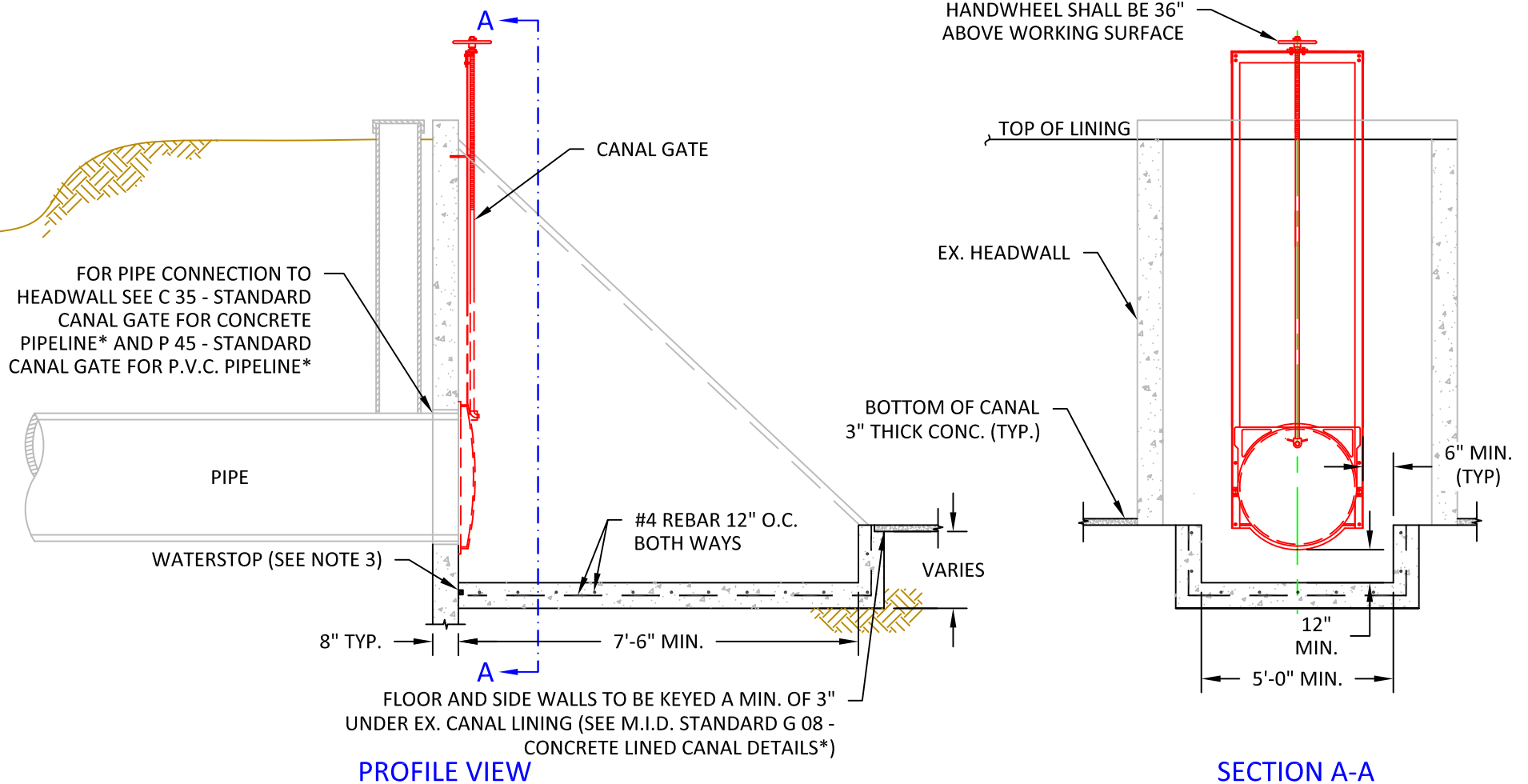

**PROFILE VIEW**

**SECTION A-A**

\*REFERENCED STANDARD(S): G 04, G 08, G 11, G 12, C 35, P 45



**STANDARD CANAL GATE WITH NEW SUMP IN EXISTING HEADWALL**

DATE: JUNE 2017  
SCALE: NONE

STANDARD #: M 60

APPROVED BY:

CHAD J. TIENKEN, P.E., P.L.S.  
CIVIL ENGINEERING MANAGER

9/7/17  
DATE



NOTES:

1. CONCRETE STRENGTH TO BE 3,000 PSI @ 28 DAYS. NO ADMIXTURES SHALL BE INCORPORATED INTO CONCRETE MIX UNLESS PRE-APPROVED BY M.I.D. SEE M.I.D. STANDARD G 04 - CONCRETE NOTES\*.
2. REINFORCED COLLAR REQUIRED FOR ALL PIPELINES GREATER THAN 18" OR FOR ALL PIPE CONNECTIONS WITH A CHANGED I.D. GREATER THAN 5".
3. THOROUGHLY BRUSH ALL DEBRIS AND CLEAN EACH END OF PIPE AROUND THE ENTIRE CIRCUMFERENCE WITH WATER PRIOR TO PLACEMENT OF CONCRETE COLLAR OR MORTAR.
4. MINIMUM #4 BARS FOR ALL COLLAR REINFORCEMENT.
5. A MINIMUM OF TWO CIRCUMFERENCE BARS REQUIRED, ONE BAR TO BE PLACED OVER THE END OF EACH PIPE WITH A MINIMUM 18" BAR LAP. THE BARS MUST HAVE A MINIMUM OF 3" CLEAR FROM EACH PIPE O.D. AND 2" MINIMUM OF CONCRETE COVER.
6. HORIZONTAL BARS SHALL BE PLACED AT 12" O.C. EQUALLY SPACED AROUND CIRCUMFERENCE OF PIPE WITH A MINIMUM OF SIX (6) HORIZONTAL BARS.
7. PROPERLY SEAL CONNECTION BY MORTARING FROM INSIDE PIPELINE AFTER PERMANENT PLACEMENT OF CONCRETE COLLAR, STARTER COUPLER AND P.V.C. PIPE. A MINIMUM MORTARED BAND WIDTH OF 5" IS REQUIRED. USE SOFT BRISTLE BRUSH TO BLEND MORTAR AND CONCRETE TOGETHER. SEE M.I.D. STANDARD G 11 - M.I.D. MORTAR MIX NOTES\*.

REV	CHANGE	DATE	BY
1	RELEASE	06/17	LH
2			
3			
4			

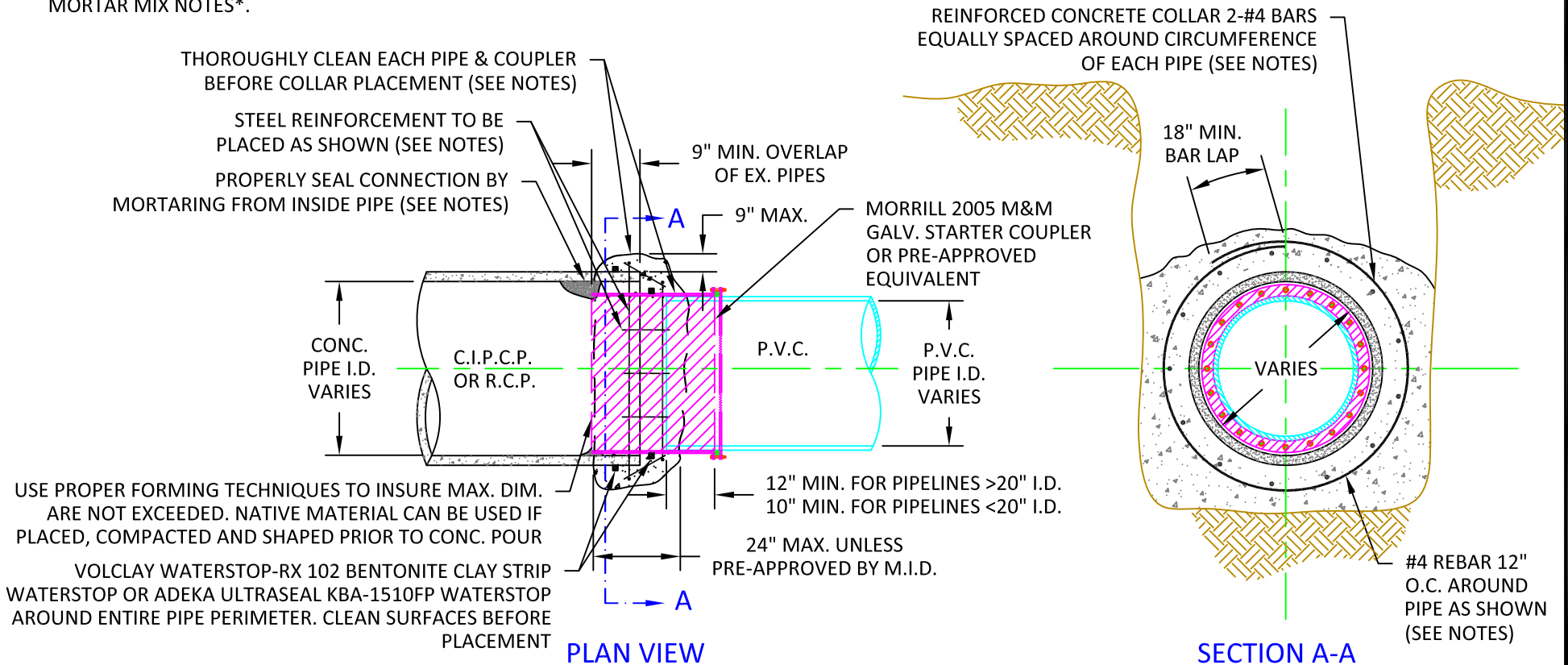

\*REFERENCED STANDARD(S): G 04, G 11



STARTER COUPLER FOR P.V.C. PIPELINE

DATE: JUNE 2017

STANDARD #:

P 01

SCALE: NONE

APPROVED BY:

*Chad J. Tienken*

CHAD J. TIENKEN, P.E., P.L.S.  
CIVIL ENGINEERING MANAGER

9/7/17

DATE

**NOTES:**

1. CONCRETE STRENGTH TO BE 3,000 PSI @ 28 DAYS. NO ADMIXTURES SHALL BE INCORPORATED INTO CONCRETE MIX UNLESS PRE-APPROVED BY M.I.D. SEE M.I.D. STANDARD G 04 - CONCRETE NOTES\*.
2. ALL PIPE SHALL ENTER STRUCTURE AT OR NEAR PERPENDICULAR ANGLES TO THE WALL OF THE STRUCTURE.
3. THOROUGHLY BRUSH ALL DEBRIS AND CLEAN BOTH PIPE AND STRUCTURE AROUND THE ENTIRE CIRCUMFERENCE WITH WATER PRIOR TO PLACEMENT OF CONCRETE OR MORTAR.
4. MINIMUM #4 BARS FOR ALL COLLAR REINFORCEMENT.
5. A MINIMUM OF TWO CIRCUMFERENCE BARS REQUIRED WITH A MINIMUM 18" BAR LAP. THE BARS MUST HAVE A MINIMUM OF 3" CLEAR FROM PIPE O.D. AND 2" MINIMUM OF CONCRETE COVER.
6. HORIZONTAL BARS SHALL BE PLACED AT 12" O.C. EQUALLY SPACED AROUND THE CIRCUMFERENCE OF THE PIPE WITH A MINIMUM OF SIX (6) HORIZONTAL BARS.
7. PROPERLY SEAL BY MORTARING FROM INSIDE OF PIPELINE AFTER PERMANENT PLACEMENT OF CONCRETE COLLAR. A MINIMUM MORTARED BAND WIDTH OF 5" IS REQUIRED. USE SOFT BRISTLE BRUSH TO BLEND MORTAR AND CONCRETE TOGETHER. SEE M.I.D. STANDARD G 11 - M.I.D. MORTAR MIX NOTES\*.
8. CANAL GATE TO BE WATERMAN C-10 CANAL GATE WITH GALVANIZED FRAME OR PRE-APPROVED EQUIVALENT.

REV	CHANGE	DATE	BY
1	RELEASE	06/17	LH
2	REVISED	04/22	LH
3			
4			

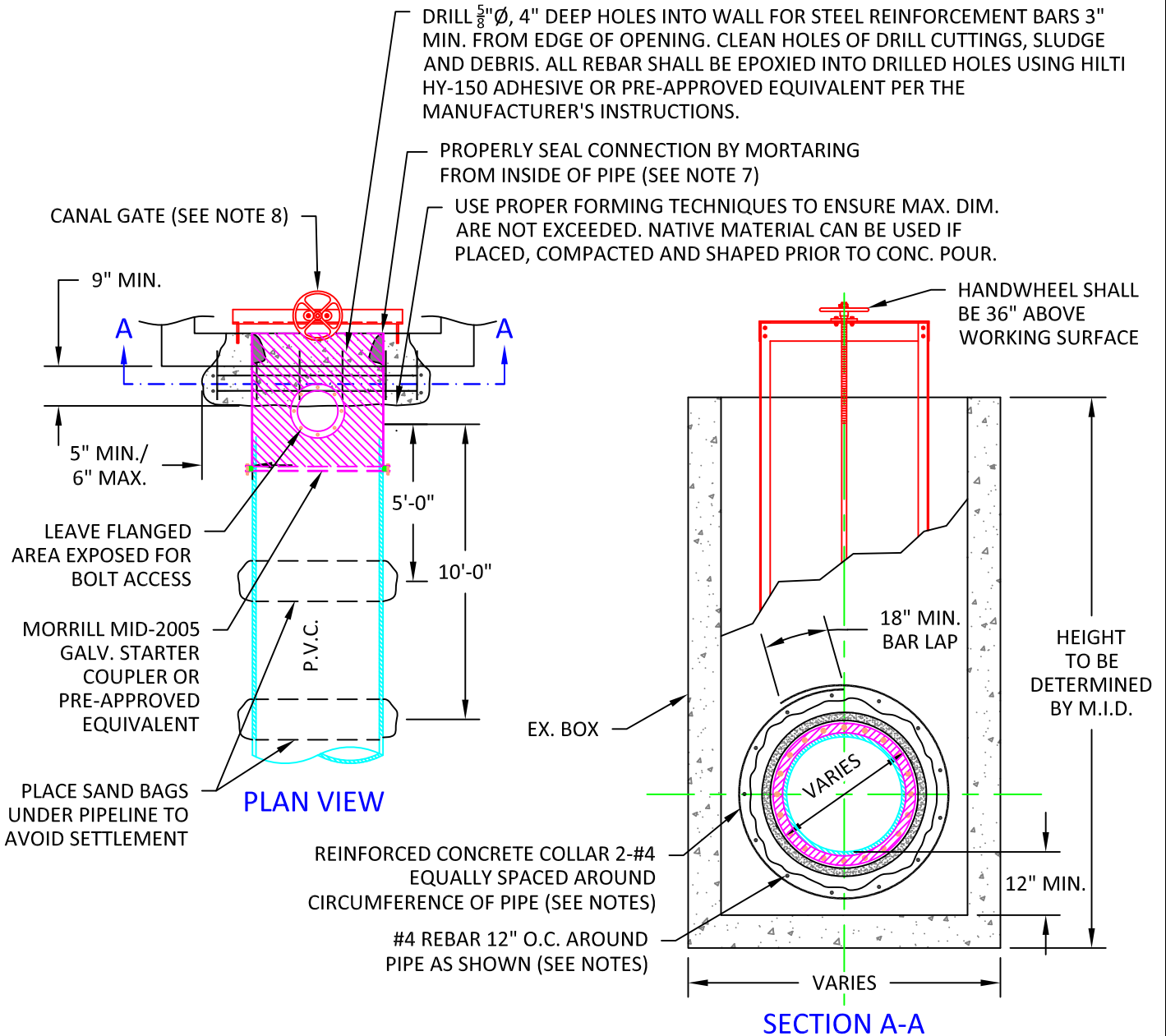

\*REFERENCED STANDARD(S): G 04, G 11



**P.V.C. CONNECTION TO EXISTING STRUCTURE**

DATE: JUNE 2017

STANDARD #:

P 05

SCALE: NONE

APPROVED BY:

*David B. Bakker*

DAVID B. BAKKER, P.E.  
SENIOR CIVIL ENGINEER

DATE: 4/29/22

**NOTES:**

1. CONCRETE STRENGTH TO BE 3,000 PSI @ 28 DAYS. NO ADMIXTURES SHALL BE INCORPORATED INTO CONCRETE MIX UNLESS PRE-APPROVED BY M.I.D. SEE M.I.D. STANDARD G 04 - CONCRETE NOTES\*.
2. ALL PIPE SHALL ENTER BOX AT OR NEAR PERPENDICULAR ANGLES TO THE BOX.
3. ALL COLD JOINTS REQUIRE 6" RUBBER WATER STOP EMBEDDED IN CENTER OF WALL AT COLD JOINT LOCATION PER MANUFACTURER'S RECOMMENDATIONS. SEE M.I.D. STANDARD G 07 - NEW CONSTRUCTION JOINT\*.
4. CANAL GATE TO BE WATERMAN C-10 CANAL GATE OR PRE-APPROVED EQUIVALENT WITH GALVANIZED FRAME.
5. IF TOP OF STRUCTURE IS 4 FEET OR MORE ABOVE SURROUNDING GRADE, A LADDER SHALL BE REQUIRED. IF TOP OF STRUCTURE IS 7.5 FEET OR MORE ABOVE SURROUNDING GRADE, HANDRAILING SHALL ALSO BE REQUIRED. REFER TO M.I.D. STANDARDS M 45 - STRUCTURE HANDRAILING\* AND M 46 - STRUCTURE LADDER\*.
6. PROPERLY SEAL ALL BOX JOINTS AND PIPES BY MORTARING FROM INSIDE OF BOX. USE SOFT BRISTLE BRUSH TO BLEND MORTAR AND CONCRETE TOGETHER. SEE M.I.D. STANDARD G 11 - M.I.D. MORTAR MIX NOTES\*.
7. WATERSTOP SURROUNDING OPENINGS SHALL BE VOLCLAY WATERSTOP-RX 102 BENTONITE CLAY STRIP OR ADEKA ULTRASEAL KBA-1510FP WATERSTOP, PLACED AROUND OUTSIDE OF COUPLER IN CENTER OF WALL.

REV	CHANGE	DATE	BY
1	RELEASE	06/17	LH
2	REVISED	04/22	LH
3			
4			

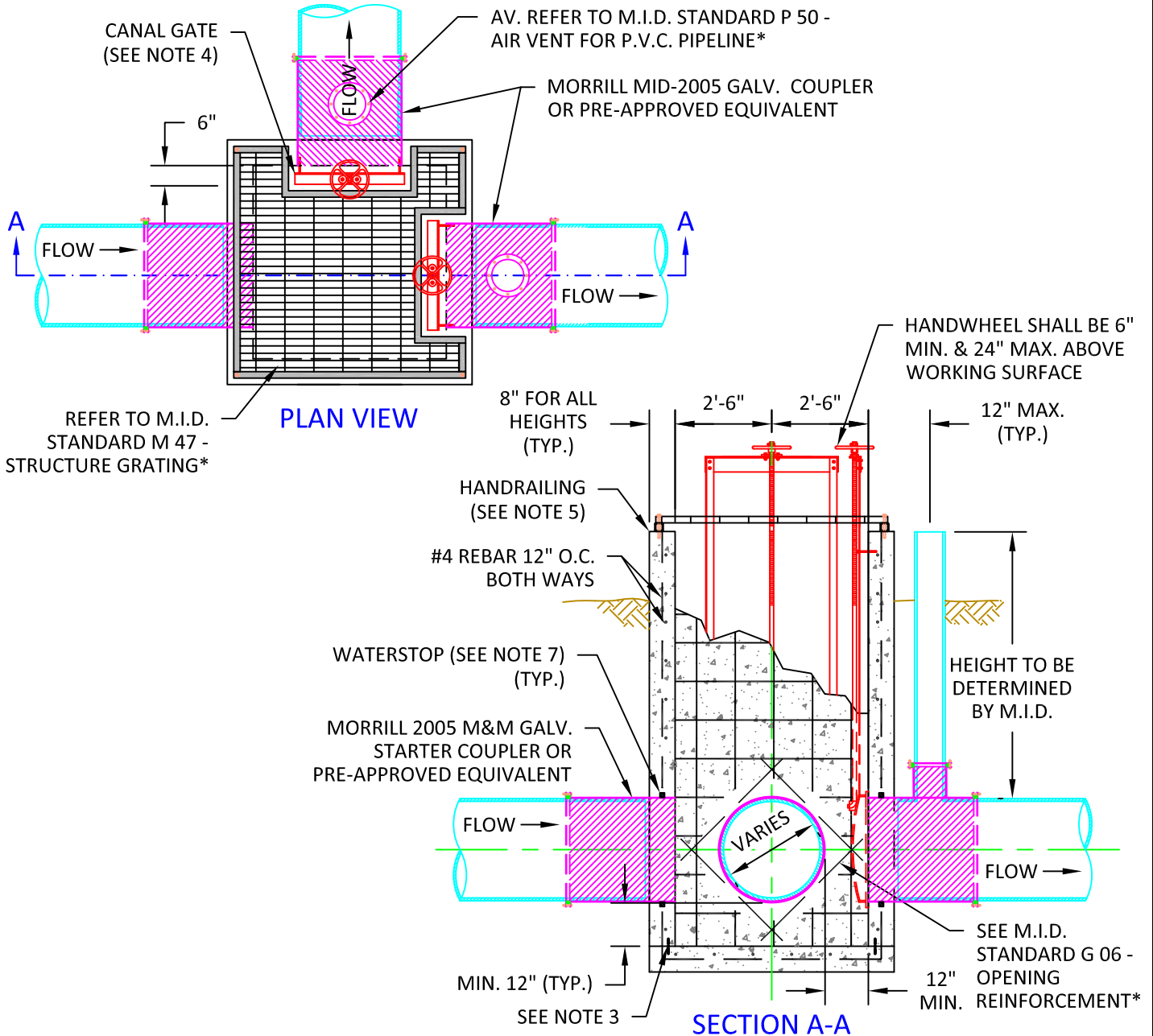

\*REFERENCED STANDARD(S): G 04, G 06, G 07, G 11, M 45, M 46, M 47, P 50



**CONTROL BOX  
FOR P.V.C. PIPELINE**

DATE: JUNE 2017

STANDARD #:

P 10

SCALE: NONE

APPROVED BY:

*David B. Bakker*

DAVID B. BAKKER, P.E.  
SENIOR CIVIL ENGINEER

DATE: 4/29/22

**NOTES:**

1. CONCRETE STRENGTH TO BE 3,000 PSI @ 28 DAYS. NO ADMIXTURES SHALL BE INCORPORATED INTO CONCRETE MIX UNLESS PRE-APPROVED BY M.I.D. SEE M.I.D. STANDARD G 04 - CONCRETE NOTES\*.
2. ALL PIPE SHALL ENTER BOX AT OR NEAR PERPENDICULAR ANGLES TO THE BOX.
3. PROPERLY SEAL ALL BOX JOINTS AND PIPES BY MORTARING FROM INSIDE OF BOX. USE SOFT BRISTLE BRUSH TO BLEND MORTAR AND CONCRETE TOGETHER. SEE M.I.D. STANDARD G 11 - M.I.D. MORTAR MIX NOTES\*.
4. CANAL GATE TO BE WATERMAN C-10 CANAL GATE OR PRE-APPROVED EQUIVALENT WITH GALVANIZED FRAME.
5. IF TOP OF STRUCTURE IS 4 FEET OR MORE ABOVE SURROUNDING GRADE, A LADDER SHALL BE REQUIRED. IF TOP OF STRUCTURE IS 7.5 FEET OR MORE ABOVE SURROUNDING GRADE, HANDRAILING SHALL ALSO BE REQUIRED. REFER TO M.I.D. STANDARDS M 45 - STRUCTURE HANDRAILING\* AND M 46 - STRUCTURE LADDER\*.

REV	CHANGE	DATE	BY
1	RELEASE	06/17	LH
2	REVISED	04/22	LH
3			
4			

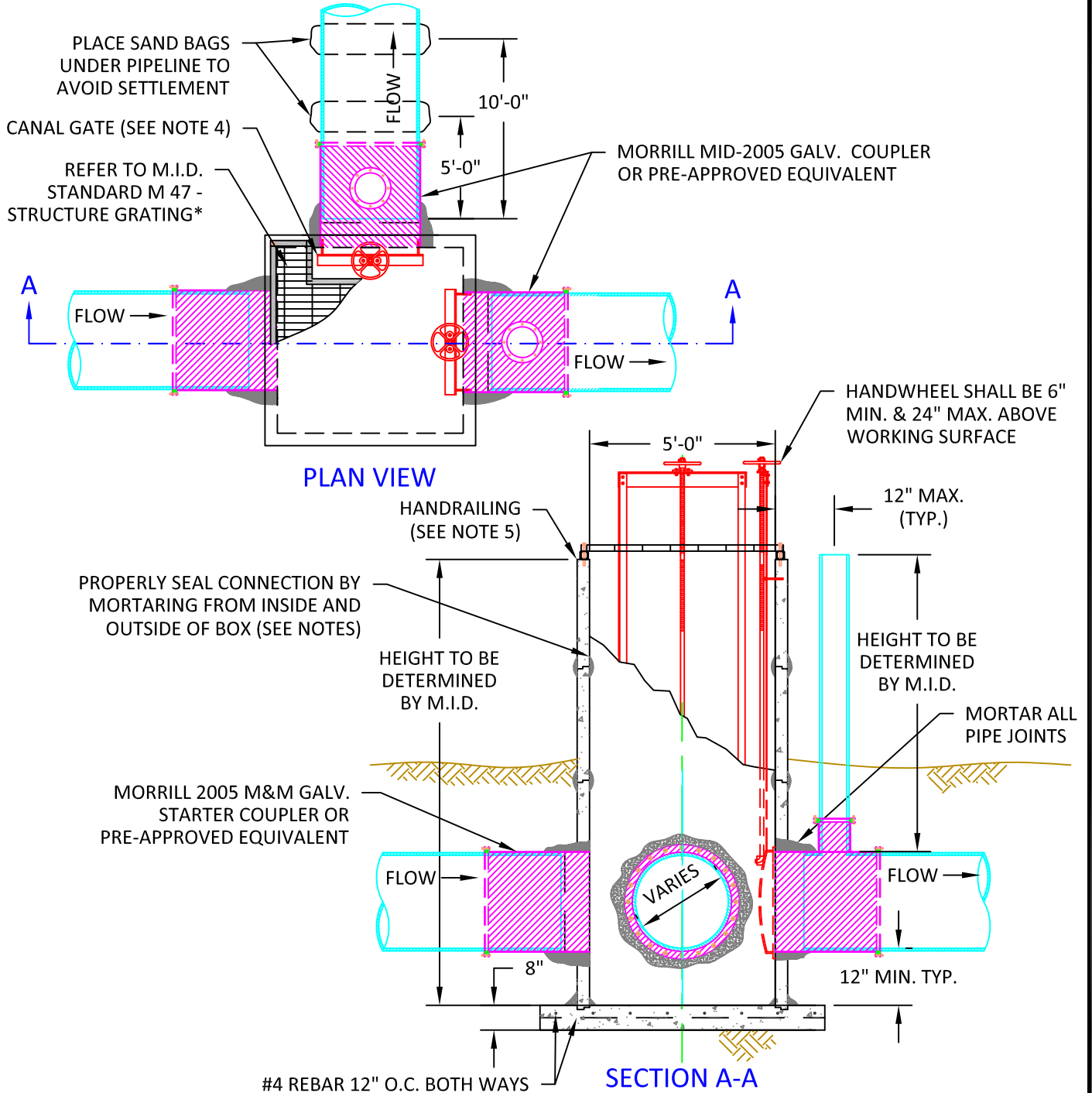

\*REFERENCED STANDARD(S): G 04, G 11, M 45, M 46, M 47



**PRECAST CONTROL BOX FOR P.V.C. PIPELINE**

DATE: JUNE 2017  
SCALE: NONE

STANDARD #: P 15

APPROVED BY:

*David B. Bakker*

DAVID B. BAKKER, P.E.  
SENIOR CIVIL ENGINEER

DATE: 4/29/22

**NOTES:**

1. CONCRETE STRENGTH TO BE 3,000 PSI @ 28 DAYS. NO ADMIXTURES SHALL BE INCORPORATED INTO CONCRETE MIX UNLESS PRE-APPROVED BY M.I.D. SEE M.I.D. STANDARD G 04 - CONCRETE NOTES\*.
2. ALL PIPE SHALL ENTER BOX AT OR NEAR PERPENDICULAR ANGLES TO THE BOX.
3. ALL COLD JOINTS REQUIRE 6" RUBBER WATER STOP EMBEDDED IN CENTER OF WALL AT COLD JOINT LOCATION PER MANUFACTURER'S RECOMMENDATIONS. SEE M.I.D. STANDARD G 07 - NEW CONSTRUCTION JOINT\*.
4. WHEN AIR VENT IS WITHIN 5' OF TRAVELED WAY, AIR VENT SHALL BE BREAK AWAY TYPE. SEE DETAIL "A".
5. PROPERLY SEAL ALL BOX JOINTS AND PIPES BY MORTARING FROM INSIDE OF BOX. USE SOFT BRISTLE BRUSH TO BLEND MORTAR AND CONCRETE TOGETHER. SEE M.I.D. STANDARD G 11 - M.I.D. MORTAR MIX NOTES\*.
6. WATERSTOP SURROUNDING OPENINGS SHALL BE VOLCLAY WATERSTOP-RX 102 BENTONITE CLAY STRIP OR ADEKA ULTRASEAL KBA-1510FP WATERSTOP, PLACED AROUND OUTSIDE OF COUPLER AND AIR VENT BASE IN CENTER OF WALL.

REV	CHANGE	DATE	BY
1	RELEASE	06/17	LH
2	REVISED	04/22	LH
3			
4			

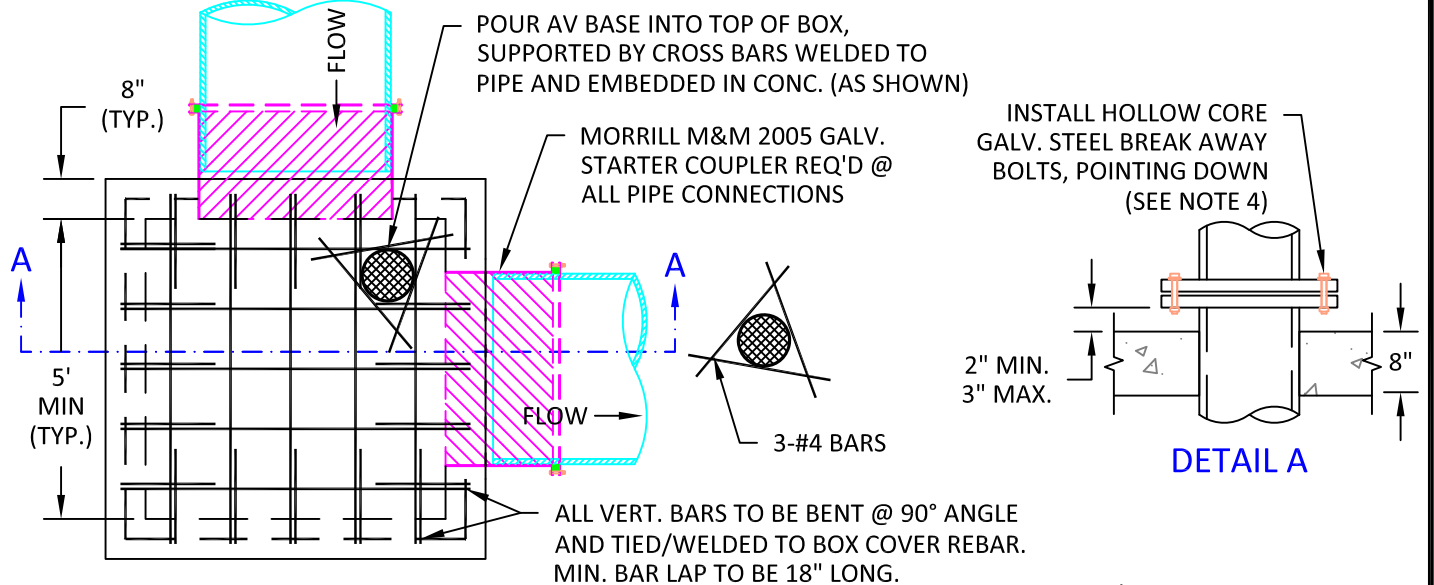

**PLAN VIEW**

**DETAIL A**

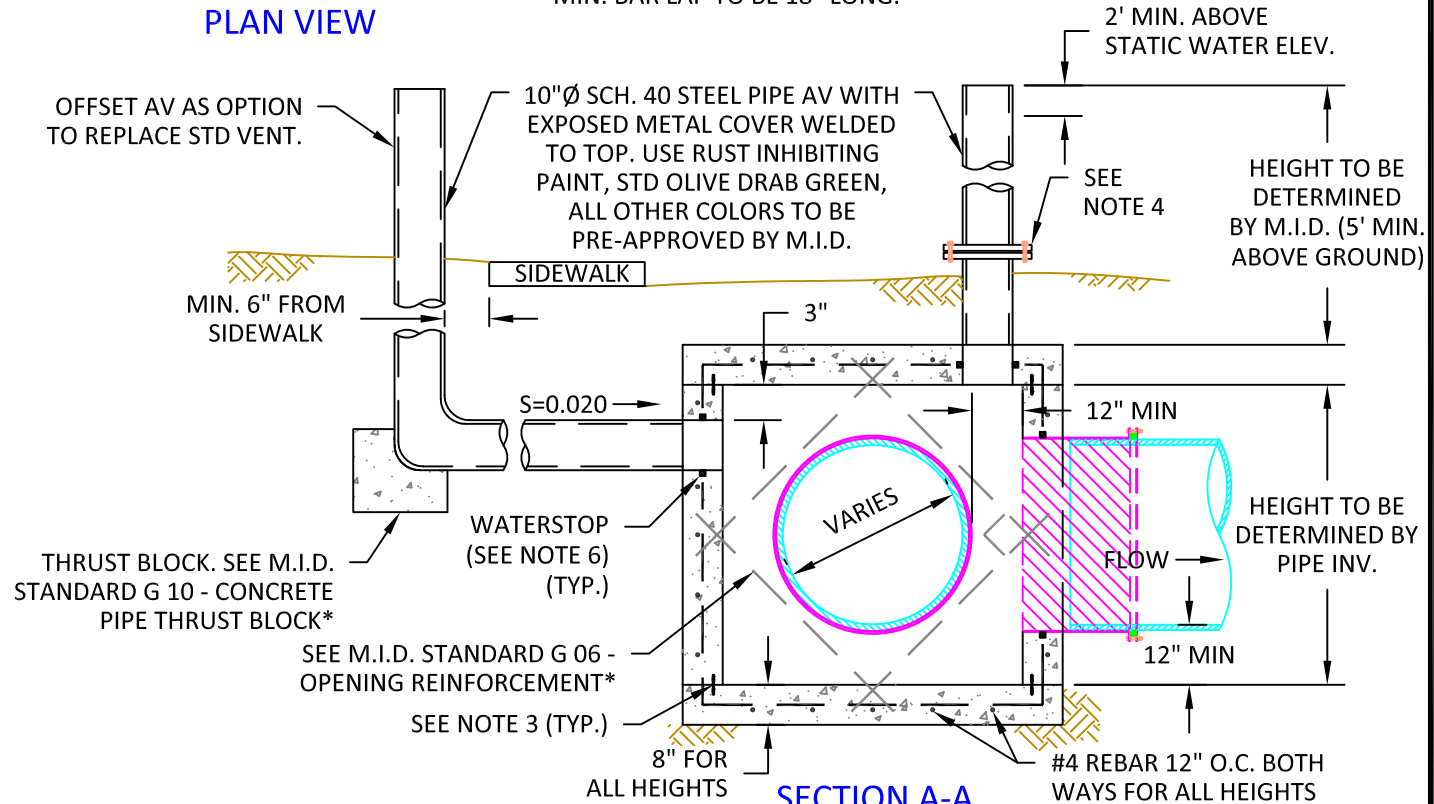

**SECTION A-A**

\*REFERENCED STANDARD(S): G 04, G 06, G 07, G 10, G 11



**PRESSURE BOX FOR P.V.C. PIPELINE**

DATE: JUNE 2017  
SCALE: NONE

STANDARD #: P 20

APPROVED BY:

*David B. Bakker*

DAVID B. BAKKER, P.E.  
SENIOR CIVIL ENGINEER

DATE: 4/29/22

**NOTES:**

1. CONCRETE STRENGTH TO BE 3,000 PSI @ 28 DAYS. NO ADMIXTURES SHALL BE INCORPORATED INTO CONCRETE MIX UNLESS PRE-APPROVED BY M.I.D. SEE M.I.D. STANDARD G 04 - CONCRETE NOTES\*.
2. ALL PIPE SHALL ENTER BOX AT OR NEAR PERPENDICULAR ANGLES TO THE BOX.
3. ALL COLD JOINTS REQUIRE 6" RUBBER WATER STOP EMBEDDED IN CENTER OF WALL AT COLD JOINT LOCATION PER MANUFACTURER'S RECOMMENDATIONS. SEE M.I.D. STANDARD G 07 - NEW CONSTRUCTION JOINT\*.
4. STANDARD 24 INCH DIAMETER HEAVY DUTY PRESSURE TYPE MANHOLE FRAME AND COVER WITH MINIMUM 4-1/2 INCH SS BOLTS - SOUTH BAY FOUNDRY A1900-R3B, D&L SUPPLY COMPANY A-1094 OR PRE-APPROVED EQUIVALENT. ALL MANHOLES TO BE INSTALLED WITH 5/16" SQUARE NEOPRENE GASKET AND BOLT GASKETS AND "M.I.D." CAST IN COVER.
5. WHEN AIR VENT IS WITHIN 5' OF TRAVELED WAY, AIR VENT SHALL BE BREAK AWAY TYPE. SEE DETAIL "A".
6. PROPERLY SEAL ALL BOX JOINTS AND PIPES BY MORTARING FROM INSIDE OF BOX. USE SOFT BRISTLE BRUSH TO BLEND MORTAR AND CONCRETE TOGETHER. SEE M.I.D. STANDARD G 11 - M.I.D. MORTAR MIX NOTES\*.
7. WATERSTOP SURROUNDING OPENINGS SHALL BE VOLCLAY WATERSTOP-RX 102 BENTONITE CLAY STRIP OR ADEKA ULTRASEAL KBA-1510FP WATERSTOP, PLACED AROUND OUTSIDE OF COUPLER AND AIR VENT BASE IN CENTER OF WALL.

REV	CHANGE	DATE	BY
1	RELEASE	06/17	LH
2	REVISED	04/22	LH
3			
4			

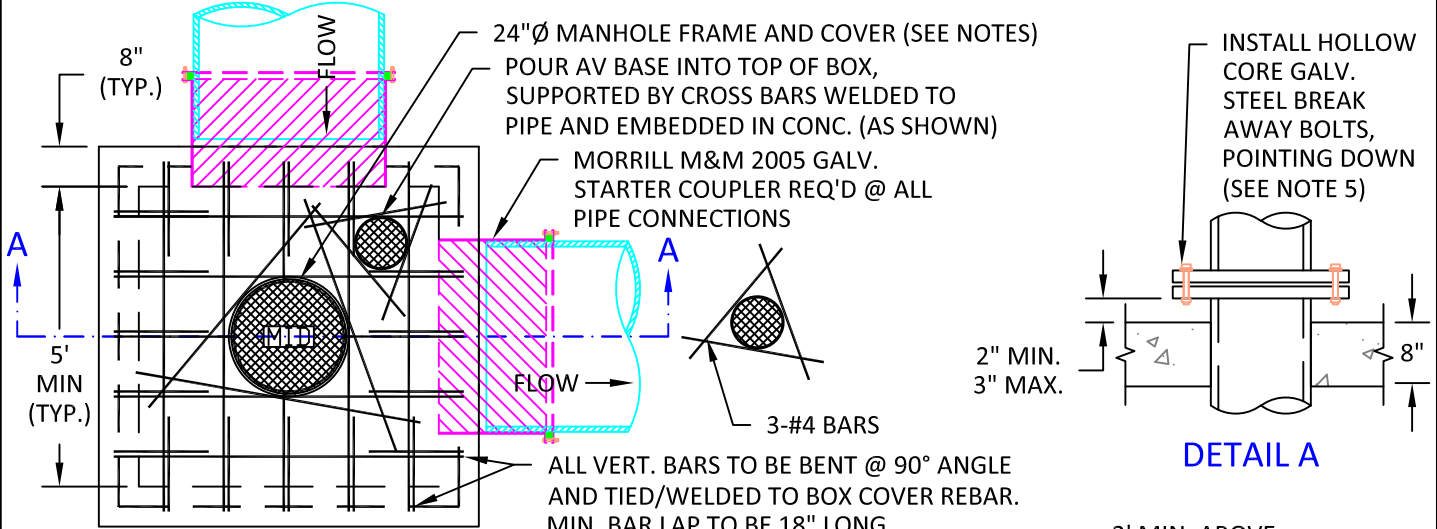

**PLAN VIEW**

**DETAIL A**

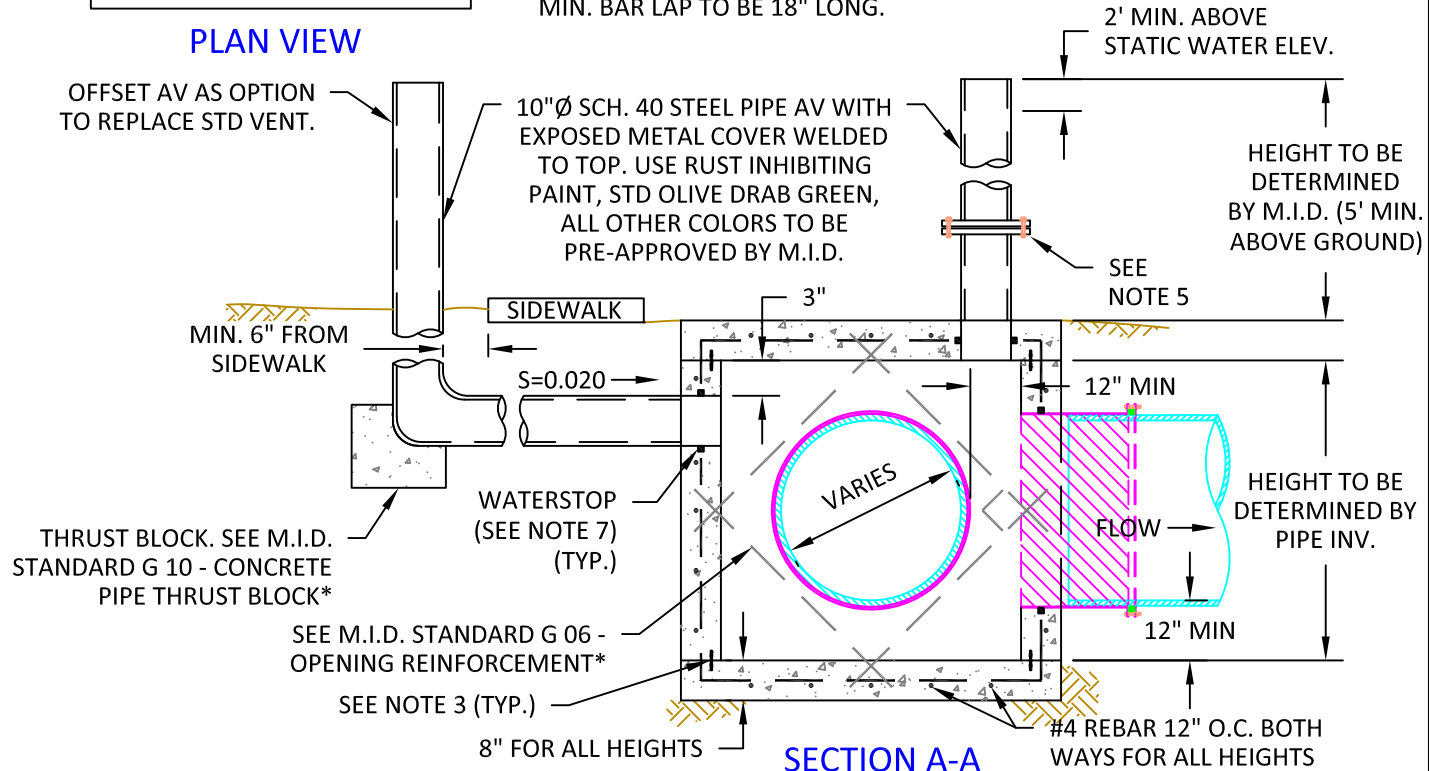

**SECTION A-A**

\*REFERENCED STANDARD(S): G 04, G 06, G 07, G 10, G 11



<b>PRESSURE MANHOLE BOX FOR P.V.C. PIPELINE</b>	
DATE: JUNE 2017	STANDARD #: P 25
SCALE: NONE	

APPROVED BY:  
  
 DAVID B. BAKKER, P.E.  
 SENIOR CIVIL ENGINEER  
 DATE: 4/29/22

**NOTES:**

1. CONCRETE STRENGTH TO BE 3,000 PSI @ 28 DAYS. NO ADMIXTURES SHALL BE INCORPORATED INTO CONCRETE MIX UNLESS PRE-APPROVED BY M.I.D. SEE M.I.D. STANDARD G 04 - CONCRETE NOTES\*.
2. ALL PIPE SHALL ENTER BOX AT OR NEAR PERPENDICULAR ANGLES TO THE BOX.
3. ALL COLD JOINTS REQUIRE 6" RUBBER WATER STOP EMBEDDED IN CENTER OF WALL AT COLD JOINT LOCATION PER MANUFACTURER'S RECOMMENDATIONS. SEE M.I.D. STANDARD G 07 - NEW CONSTRUCTION JOINT\*.
4. CANAL GATE TO BE WATERMAN C-10 CANAL GATE OR PRE-APPROVED EQUIVALENT WITH GALVANIZED FRAME.
5. IF TOP OF STRUCTURE IS 4 FEET OR MORE ABOVE SURROUNDING GRADE, A LADDER SHALL BE REQUIRED. IF TOP OF STRUCTURE IS 7.5 FEET OR MORE ABOVE SURROUNDING GRADE, HANDRAILING SHALL ALSO BE REQUIRED. REFER TO M.I.D. STANDARDS M 45 - STRUCTURE HANDRAILING\* AND M 46 - STRUCTURE LADDER\*.
6. PROPERLY SEAL ALL BOX JOINTS AND PIPES BY MORTARING FROM INSIDE OF BOX. USE SOFT BRISTLE BRUSH TO BLEND MORTAR AND CONCRETE TOGETHER. SEE M.I.D. STANDARD G 11 - M.I.D. MORTAR MIX NOTES\*.
7. WATERSTOP SURROUNDING OPENINGS SHALL BE VOLCLAY WATERSTOP-RX 102 BENTONITE CLAY STRIP OR ADEKA ULTRASEAL KBA-1510FP WATERSTOP, PLACED AROUND OUTSIDE OF COUPLER IN CENTER OF WALL.

REV	CHANGE	DATE	BY
1	RELEASE	06/17	LH
2	REVISED	04/22	LH
3			
4			

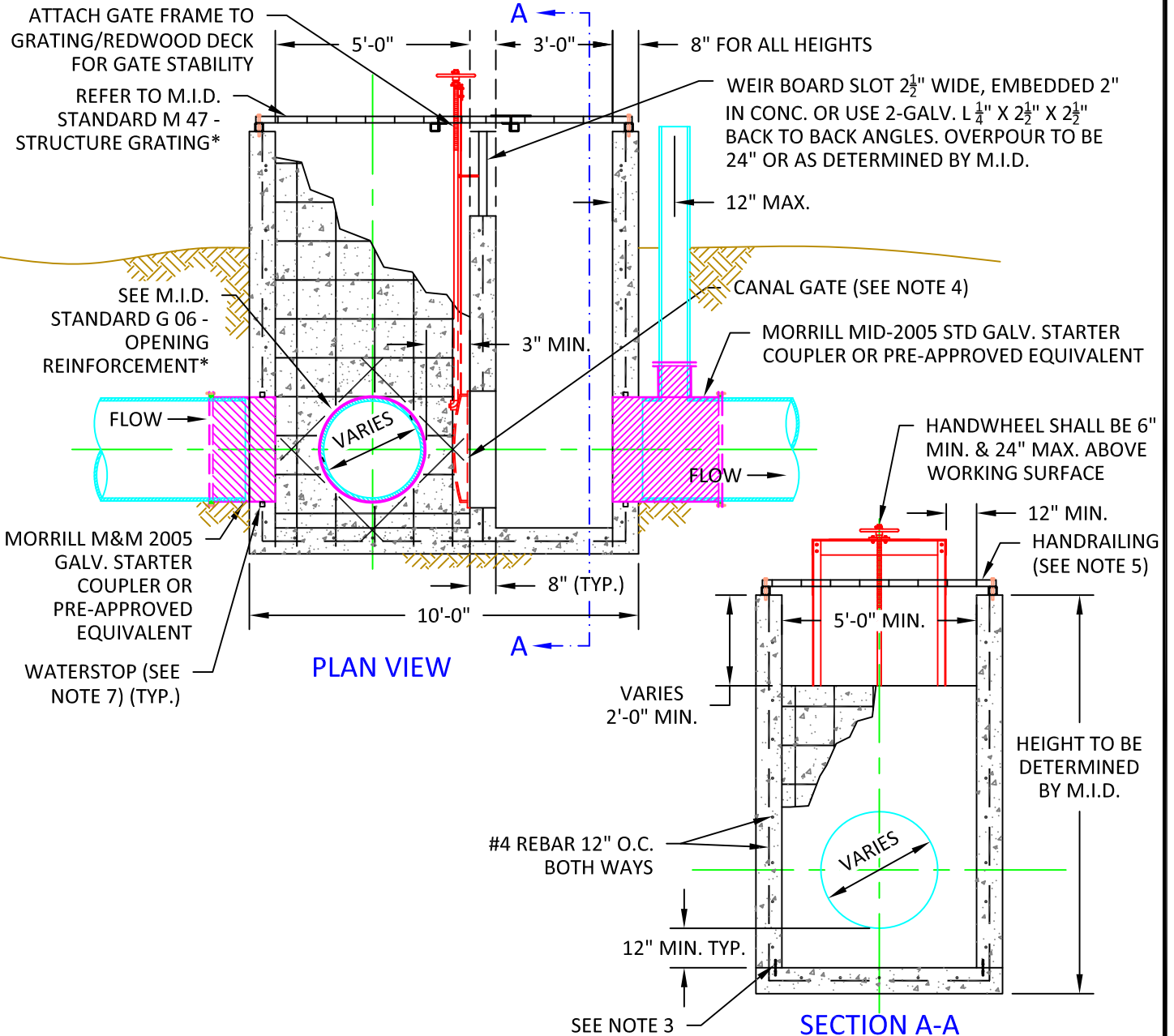

\*REFERENCED STANDARD(S): G 04, G 06, G 07, G 11, M 45, M 46, M 47



**OVERPOUR BOX  
FOR P.V.C. PIPELINE**

DATE: JUNE 2017      STANDARD #: P 30

SCALE: NONE

APPROVED BY:

*David B. Bakker*

DAVID B. BAKKER, P.E.  
SENIOR CIVIL ENGINEER

DATE: 4/29/22

**NOTES:**

1. CONCRETE STRENGTH TO BE 3,000 PSI @ 28 DAYS. NO ADMIXTURES SHALL BE INCORPORATED INTO CONCRETE MIX UNLESS PRE-APPROVED BY M.I.D. SEE M.I.D. STANDARD G 04 - CONCRETE NOTES\*.
2. SAW CUT, THOROUGHLY BRUSH AWAY DEBRIS AND CLEAN EXISTING LINING PRIOR TO CONCRETE PLACEMENT.
3. SEE M.I.D. STANDARD G 13 - STANDARD CANAL GATE NOTES\* FOR STANDARD INSTALLATION AND CONSTRUCTION NOTES.

REV	CHANGE	DATE	BY
1	RELEASE	06/17	LH
2	REVISED	04/22	LH
3			
4			

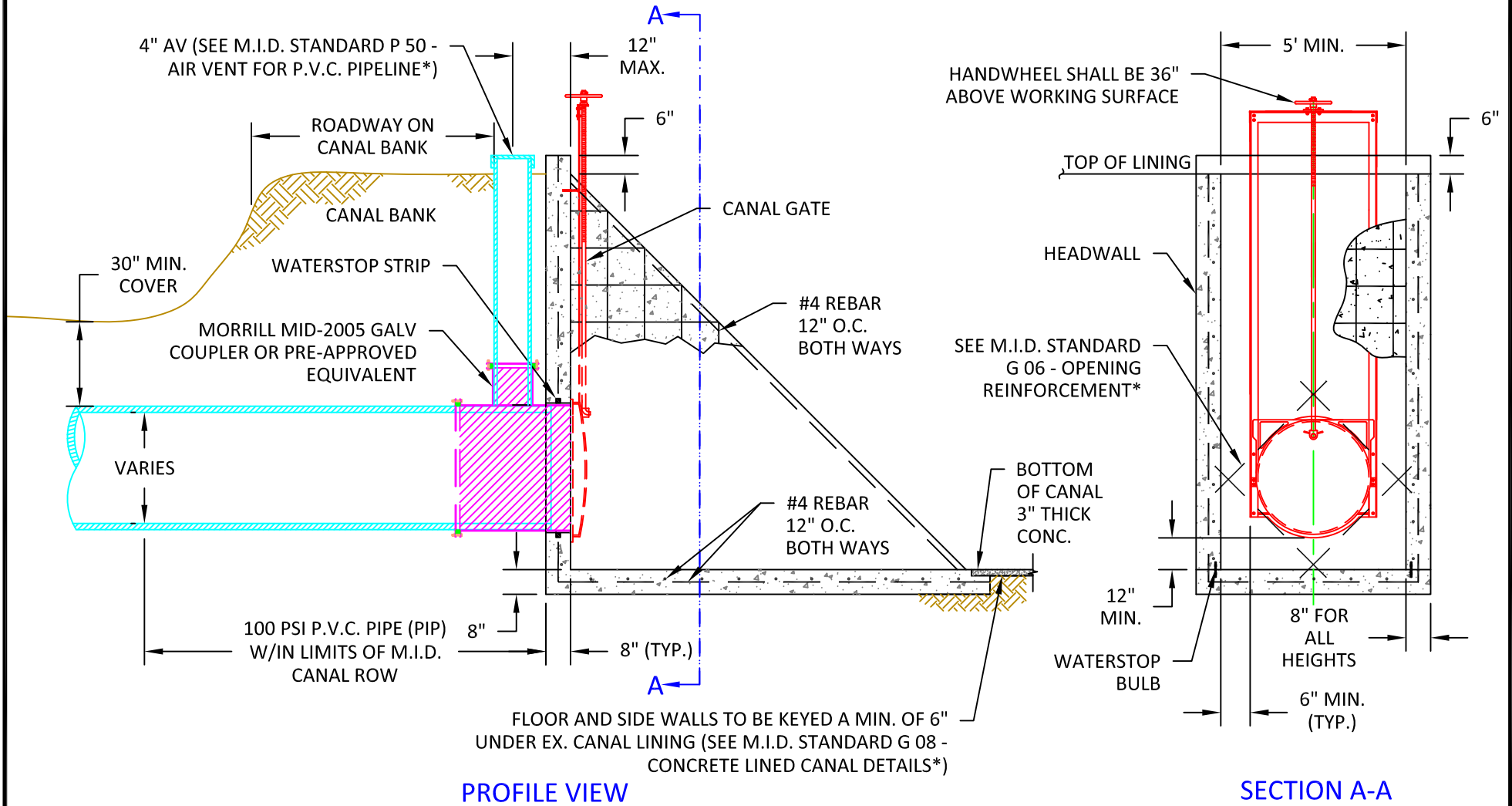

\*REFERENCED STANDARD(S): G 04, G 06, G 08, G 13, P 50



**STANDARD CANAL GATE  
FOR P.V.C. PIPELINE**

DATE: JUNE 2017  
SCALE: NONE

STANDARD #:  
P 45

APPROVED BY:

*David B. Bakker*

DAVID B. BAKKER, P.E.  
SENIOR CIVIL ENGINEER

4/29/22

DATE



**NOTES:**

1. CONCRETE STRENGTH TO BE 3,000 PSI @ 28 DAYS. NO ADMIXTURES SHALL BE INCORPORATED INTO CONCRETE MIX UNLESS PRE-APPROVED BY M.I.D SEE M.I.D. STANDARD G 04 - CONCRETE NOTES\*.
2. SAW CUT, THOROUGHLY BRUSH AWAY DEBRIS AND CLEAN EXISTING LINING PRIOR TO CONCRETE PLACEMENT.
3. SEE M.I.D. STANDARD G 13 - STANDARD CANAL GATE NOTES\* FOR STANDARD INSTALLATION AND CONCRETE NOTES.

REV	CHANGE	DATE	BY
1	RELEASE	06/17	LH
2	REVISED	04/22	LH
3			
4			

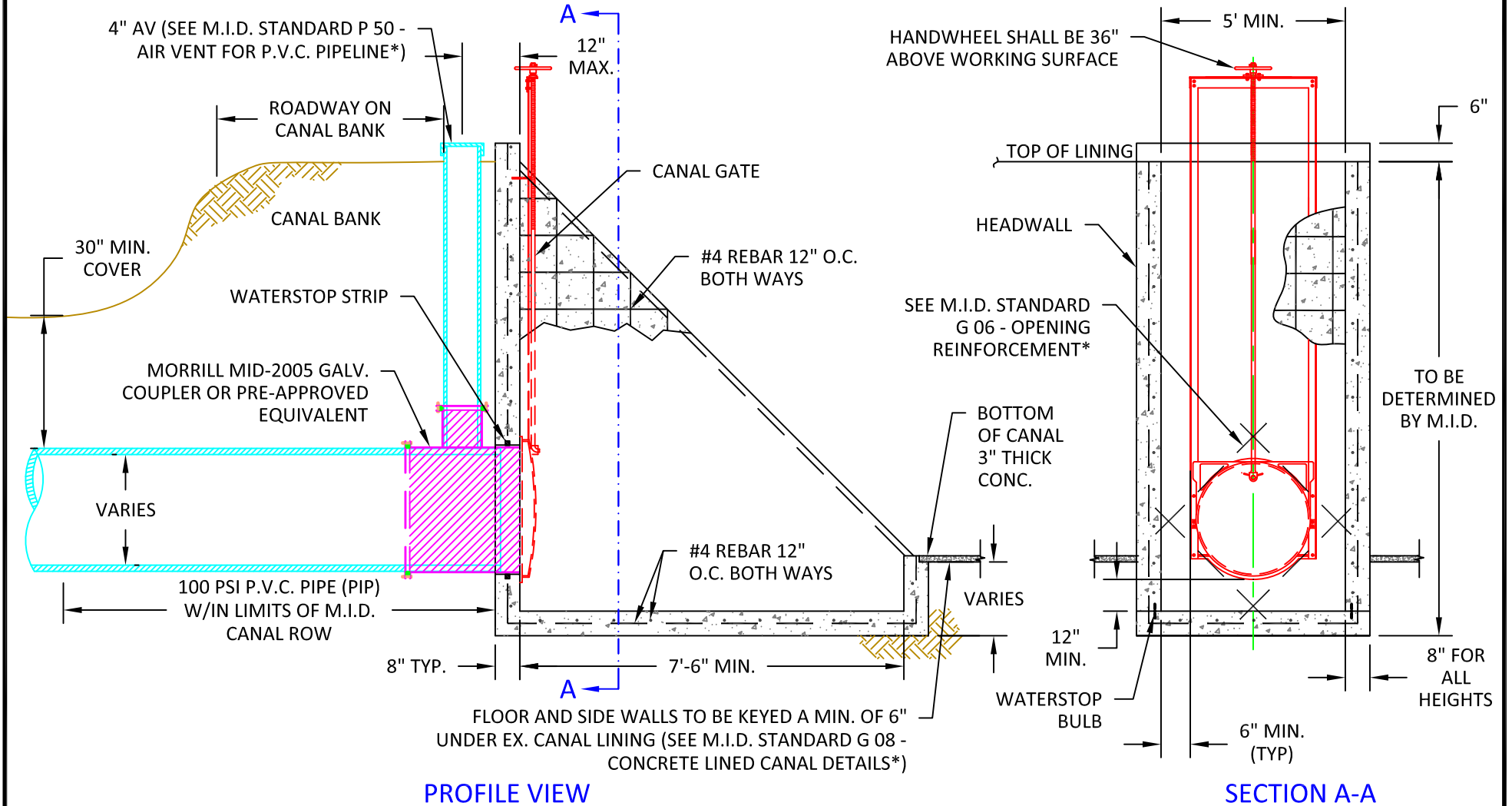

\*REFERENCED STANDARD(S): G 04, G 06, G 08, G 13, P 50



**STANDARD CANAL GATE  
FOR P.V.C. PIPELINE WITH SUMP**

DATE: JUNE 2017  
SCALE: NONE

STANDARD #:  
P 46

APPROVED BY:

*David B. Bakker*  
DAVID B. BAKKER, P.E.  
SENIOR CIVIL ENGINEER

*4/29/22*  
DATE

**NOTES:**

1. CONCRETE STRENGTH TO BE 3,000 PSI @ 28 DAYS. NO ADMIXTURES SHALL BE INCORPORATED INTO CONCRETE MIX UNLESS PRE-APPROVED BY M.I.D. SEE M.I.D. STANDARD G 04 - CONCRETE NOTES\*.
2. SEE M.I.D. STANDARD G 13 - STANDARD CANAL GATE NOTES\* FOR STANDARD INSTALLATION AND CONSTRUCTION NOTES.

REV	CHANGE	DATE	BY
1	RELEASE	06/17	LH
2	REVISED	04/22	LH
3			
4			

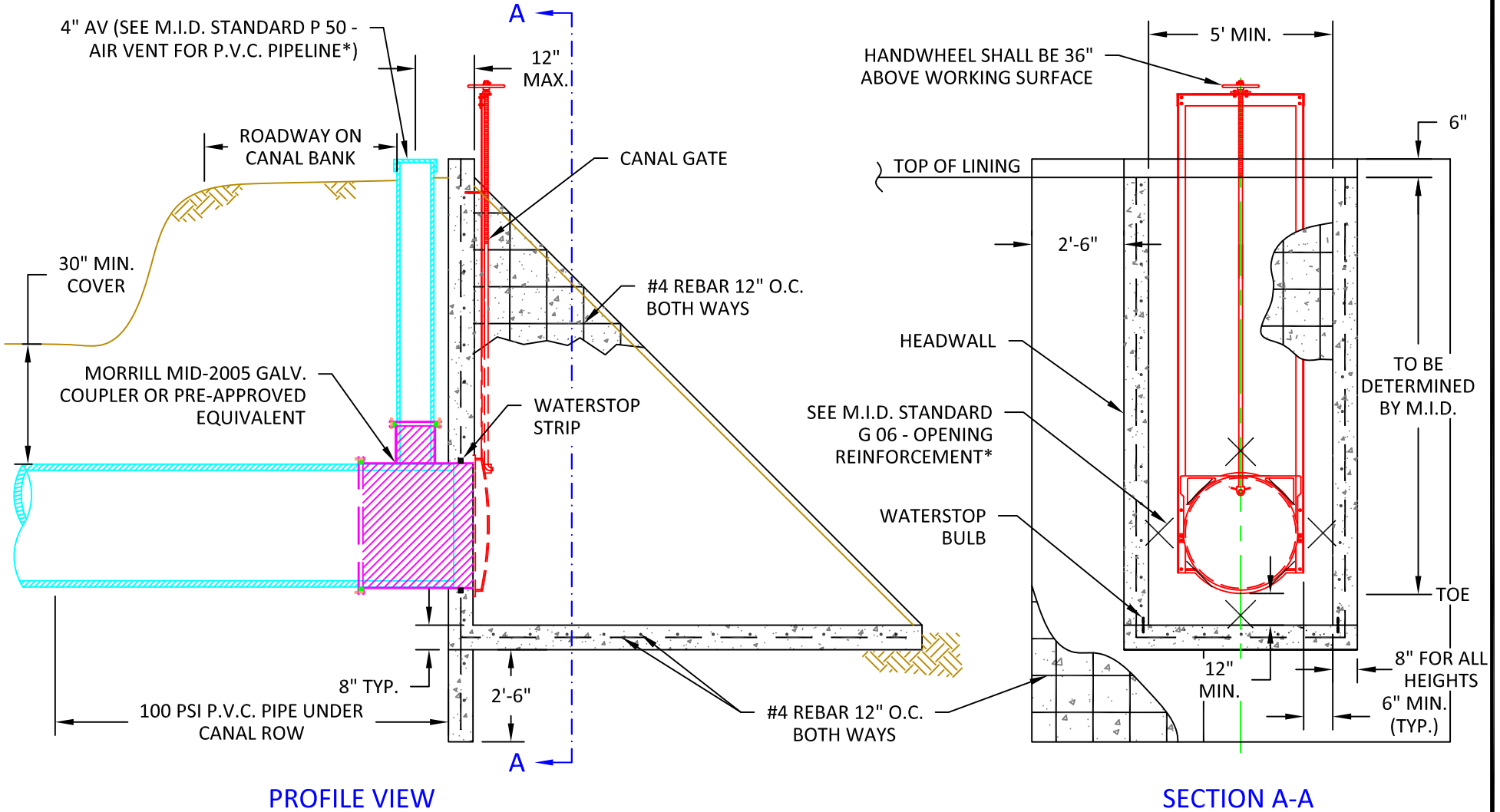

\*REFERENCED STANDARD(S): G 04, G 06, G 13, P 50

**DIRT DITCH STANDARD CANAL GATE FOR P.V.C. PIPELINE**



DATE: JUNE 2017  
SCALE: NONE

STANDARD #:  
P 47

APPROVED BY:

*David B. Bakker*

DAVID B. BAKKER, P.E.  
SENIOR CIVIL ENGINEER

4/29/22  
DATE

**NOTES:**

1. THOROUGHLY BRUSH ALL DEBRIS AND CLEAN EACH END OF PIPE AROUND THE ENTIRE CIRCUMFERENCE PRIOR TO PLACEMENT OF SADDLE.
2. USE WELD-ON P-68 PURPLE PRIMER AND WELD-ON 2719 HIGH STRENGTH SOLVENT CEMENT OR PRE-APPROVED EQUIVALENT FOR CEMENTING SADDLE TO PIPE.
3. AFTER PLACEMENT OF SADDLE WITH GLUE AND STRAPS, USE WELD-ON 810 TWO PART EPOXY OR PRE-APPROVED EQUIVALENT. EPOXY TO BE PLACED IN GAP BETWEEN INSIDE OF SADDLE AND TOP OF MAIN PIPELINE.
4. MINIMUM 10" DIAMETER FOR ALL VENT PIPES. ALL PIPE COVERS MUST BE REMOVABLE.
5. AIR VENTS SHALL BE INSTALLED AT 500 FT INTERVALS, AT PIPELINE GRADE CHANGES, AT HIGH POINTS, AND IMMEDIATELY D/S OF INLET STRUCTURES.

REV	CHANGE	DATE	BY
1	RELEASE	06/17	LH
2			
3			
4			

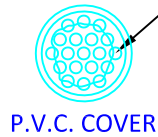

DRILL HOLES IN CAP OF VENT PIPE. 40% OF MATERIAL MUST BE REMOVED

WHEN USING SADDLE, CUT HOLE INTO MAIN PIPELINE PRIOR TO PLACING SADDLE. DIA. OF HOLE MUST BE SMALLER THAN SADDLE DIA.

ATTACH AV W/ SADDLE AND STRAPS

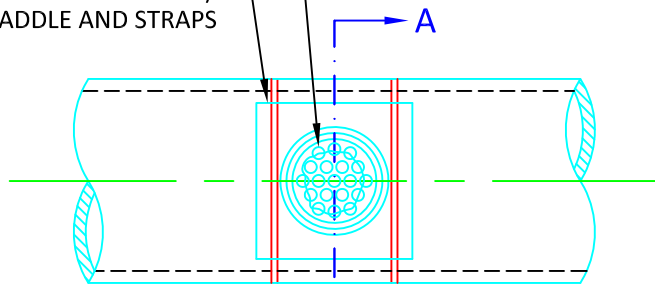

**SADDLE PLAN VIEW**

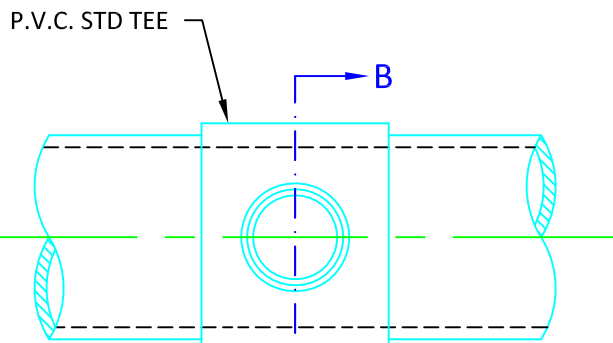

**TEE PLAN VIEW**

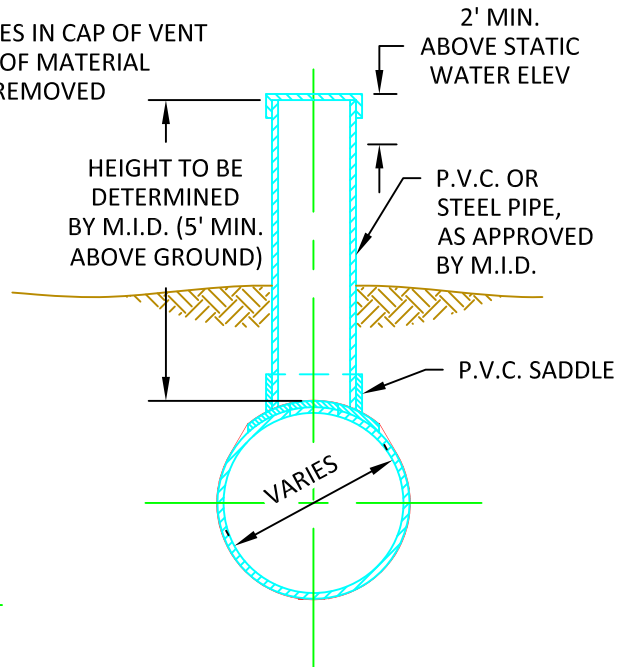

**SECTION A-A**

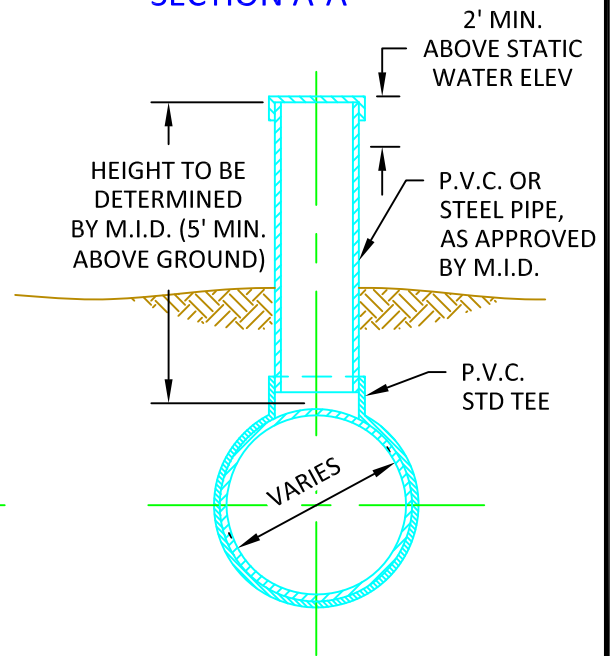

**SECTION B-B**



**AIR VENT FOR P.V.C. PIPELINE**

DATE: JUNE 2017

STANDARD #:

P 50

SCALE: NONE

APPROVED BY:

CHAD J. TIENKEN, P.E., P.L.S.  
CIVIL ENGINEERING MANAGER

DATE: 9/7/17

**NOTES:**

1. CONCRETE STRENGTH TO BE 3,000 PSI @ 28 DAYS. NO ADMIXTURES SHALL BE INCORPORATED INTO CONCRETE MIX UNLESS PRE-APPROVED BY M.I.D. SEE M.I.D. STANDARD G 04 - CONCRETE NOTES\*.
2. ALL PIPE SHALL ENTER BOX AT OR NEAR PERPENDICULAR ANGLES TO THE BOX.
3. ALL COLD JOINTS REQUIRE 6" RUBBER WATER STOP EMBEDDED IN CENTER OF WALL AT COLD JOINT LOCATION PER MANUFACTURER'S RECOMMENDATIONS. SEE M.I.D. STANDARD G 07 - NEW CONSTRUCTION JOINT\*.
4. GRATE REQUIRED ONLY FOR INLET STRUCTURE.
5. PROPERLY SEAL ALL BOX JOINTS AND PIPES BY MORTARING FROM INSIDE OF BOX. USE SOFT BRISTLE BRUSH TO BLEND MORTAR AND CONCRETE TOGETHER. SEE M.I.D. STANDARD G 11 - M.I.D. MORTAR MIX NOTES\*.
6. WATERSTOP SURROUNDING OPENINGS SHALL BE VOLCLAY WATERSTOP-RX 102 BENTONITE CLAY STRIP OR ADEKA ULTRASEAL KBA-1510FP WATERSTOP, PLACED AROUND OUTSIDE OF COUPLER IN CENTER OF WALL.

REV	CHANGE	DATE	BY
1	RELEASE	06/17	LH
2	REVISED	04/22	LH
3			
4			

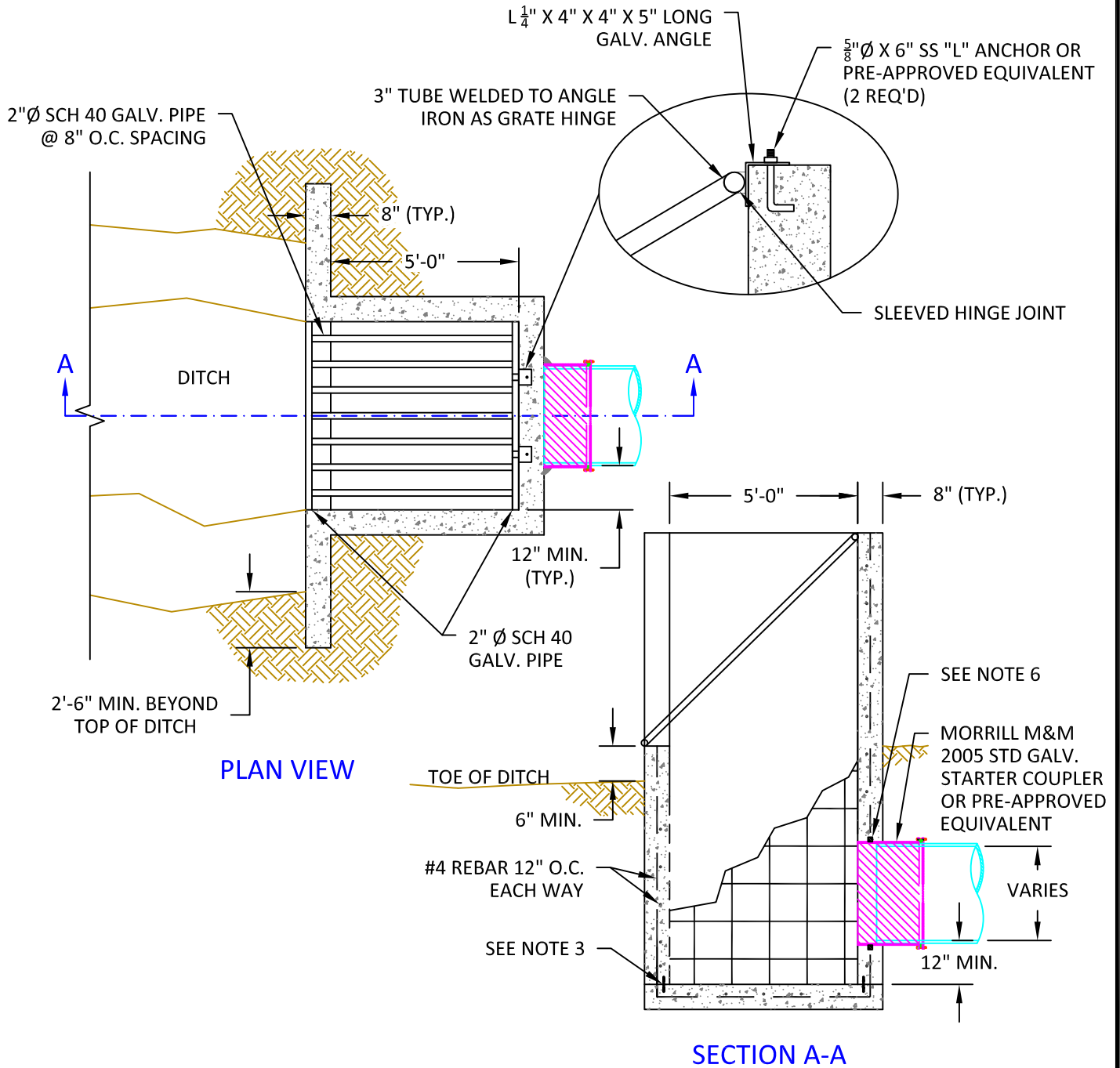

\*REFERENCED STANDARD(S): G 04, G 07, G 11



**INLET / OUTLET BOX STRUCTURE FOR P.V.C. PIPELINE**

DATE: JUNE 2017

STANDARD #:

P 55

SCALE: NONE

APPROVED BY:

*David B. Bakker*

DAVID B. BAKKER, P.E.  
SENIOR CIVIL ENGINEER

DATE: 4/29/22

**NOTES:**

1. CONCRETE STRENGTH TO BE 3,000 PSI @ 28 DAYS. NO ADMIXTURES SHALL BE INCORPORATED INTO CONCRETE MIX UNLESS PRE-APPROVED BY M.I.D. SEE M.I.D. STANDARD G 04 - CONCRETE NOTES\*.
2. PROPERLY SEAL CONNECTION BY MORTARING FROM INSIDE PIPELINE AFTER PERMANENT PLACEMENT OF FIELD VALVE OPENING. USE SOFT BRISTLE BRUSH TO BLEND MORTAR AND CONCRETE TOGETHER. SEE M.I.D. STANDARD G 11 - M.I.D. MORTAR MIX NOTES\*.
3. TWO WAY VALVE STRUCTURE NOT TO BE SUBSTITUTED FOR ONE WAY VALVE STRUCTURE OR HORSE SHOE VALVE STRUCTURE WHEN WATER FLOW IS TO BE DIVERTED IN ONLY ONE DIRECTION.

REV	CHANGE	DATE	BY
1	RELEASE	06/17	LH
2	REVISED	04/22	LH
3			
4			

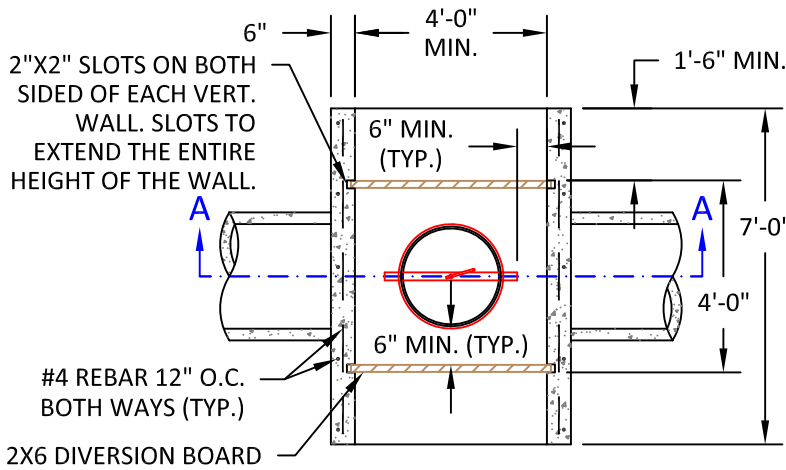

**TWO WAY CAST VALVE STRUCTURE  
TOP VIEW**

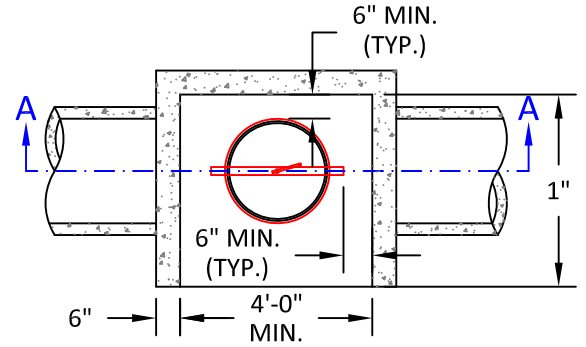

**ONE WAY VALVE STRUCTURE  
TOP VIEW**

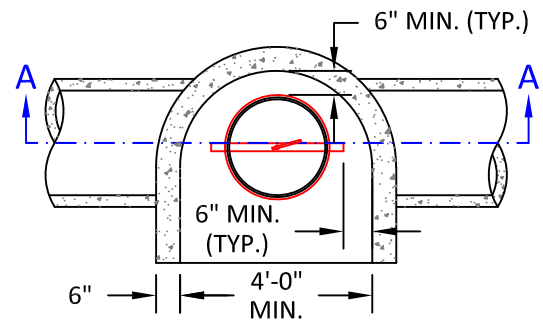

**HORSE SHOE VALVE STRUCTURE  
TOP VIEW**

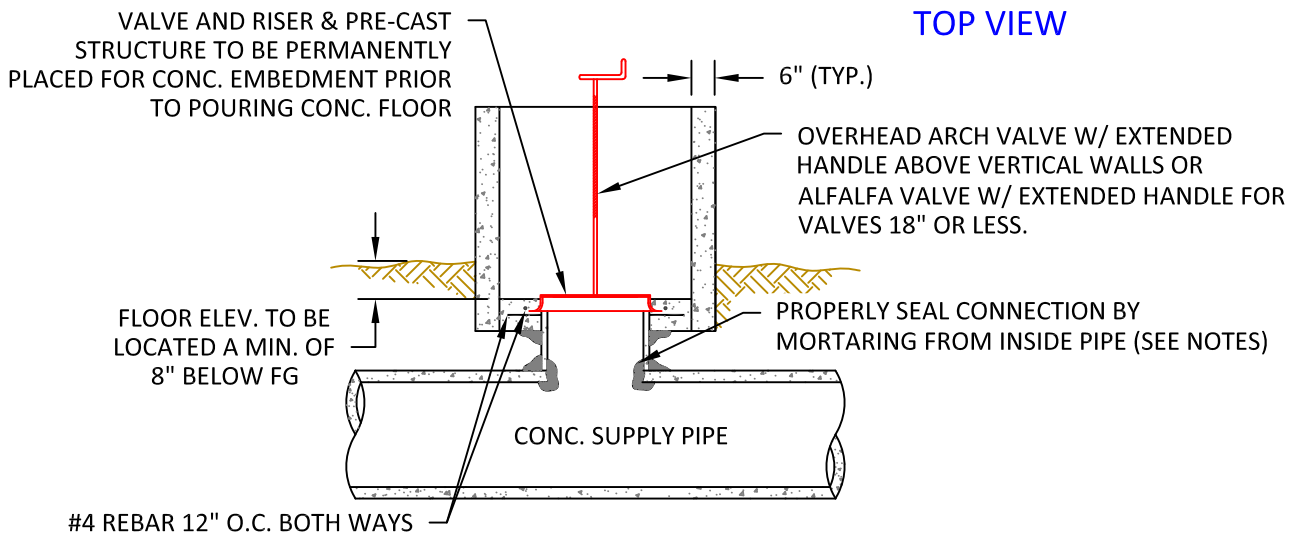

**SECTION A-A**

\*REFERENCED STANDARD(S): G 04, G 11



**FIELD VALVE STRUCTURE  
FOR CONCRETE PIPELINE**

DATE: JUNE 2017  
SCALE: NONE

STANDARD #:  
V 01

APPROVED BY:

*David B. Bakker*

DAVID B. BAKKER, P.E.  
SENIOR CIVIL ENGINEER

DATE: 4/29/22

**NOTES:**

1. CONCRETE STRENGTH TO BE 3,000 PSI @ 28 DAYS. NO ADMIXTURES SHALL BE INCORPORATED INTO CONCRETE MIX UNLESS PRE-APPROVED BY M.I.D. SEE M.I.D. STANDARD G 04 - CONCRETE NOTES\*.
2. PROPERLY SEAL PIPES BY MORTARING FROM INSIDE BOX. USE SOFT BRISTLE BRUSH TO BLEND MORTAR AND CONCRETE TOGETHER. SEE M.I.D. STANDARD G 11 - M.I.D. MORTAR MIX NOTES\*.
3. USE WELD-ON P-68 PURPLE PRIMER AND WELD-ON 810 2-PART ADHESIVE TO ATTACH IRON GATE TO P.V.C. PIPE.
4. TWO WAY VALVE STRUCTURE NOT TO BE SUBSTITUTED FOR ONE WAY VALVE STRUCTURE OR HORSE SHOE VALVE STRUCTURE WHEN WATER FLOW IS TO BE DIVERTED IN ONLY ONE DIRECTION.

REV	CHANGE	DATE	BY
1	RELEASE	06/17	LH
2	REVISED	04/22	LH
3			
4			

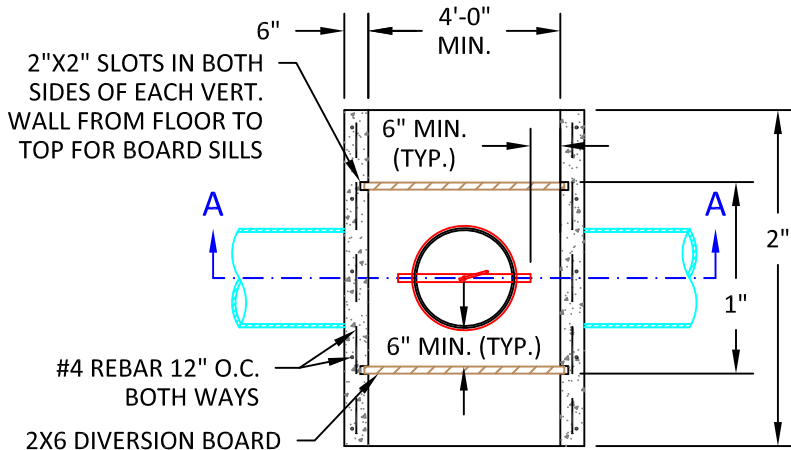

**TWO WAY CAST VALVE STRUCTURE TOP VIEW**

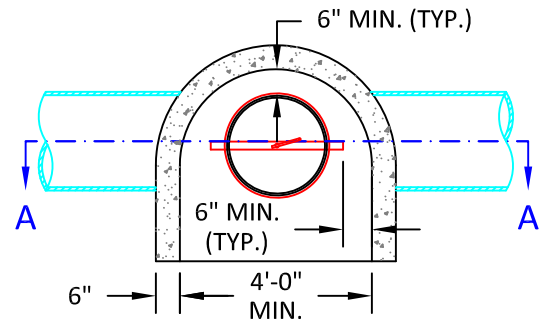

**HORSE SHOE VALVE STRUCTURE TOP VIEW**

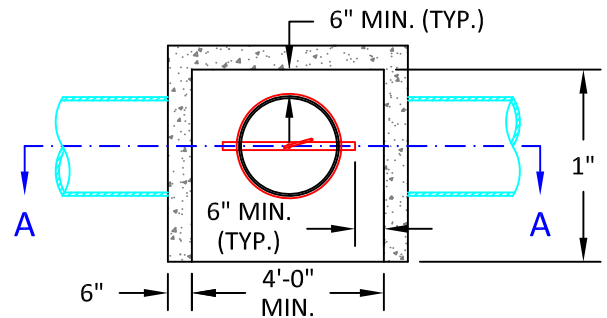

**ONE WAY VALVE STRUCTURE TOP VIEW**

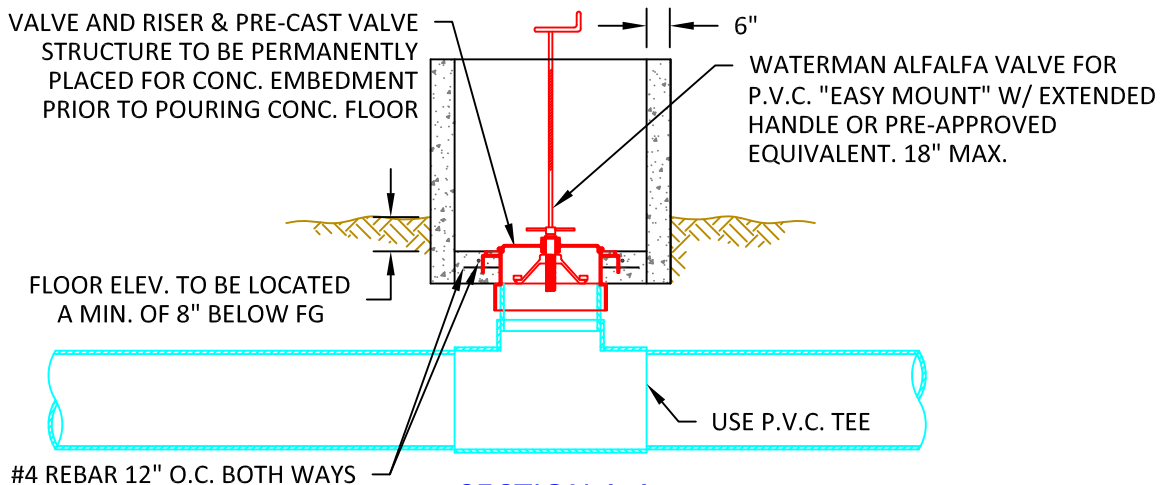

**SECTION A-A**

\*REFERENCED STANDARD(S): G 04, G 11



**FIELD VALVE STRUCTURES FOR P.V.C. PIPELINE**

DATE: JUNE 2017

STANDARD #:

V 20

SCALE: NONE

APPROVED BY:

*David B. Bakker*

DAVID B. BAKKER, P.E.  
SENIOR CIVIL ENGINEER

DATE: 4/29/22

**NOTES:**

1. THOROUGHLY BRUSH ALL DEBRIS AND CLEAN EACH END OF PIPE AROUND THE ENTIRE CIRCUMFERENCE PRIOR TO PLACEMENT OF TEE.
2. USE WELD-ON P-68 PURPLE PRIMER AND WELD-ON 2719 HIGH STRENGTH SOLVENT CEMENT OR PRE-APPROVED EQUIVALENT FOR CEMENTING TEE TO PIPE.
3. USE WELD-ON 810 2-PART ADHESIVE TO ATTACH LINE GATE TO P.V.C. PIPE.

REV	CHANGE	DATE	BY
1	RELEASE	04/22	LH
2			
3			
4			

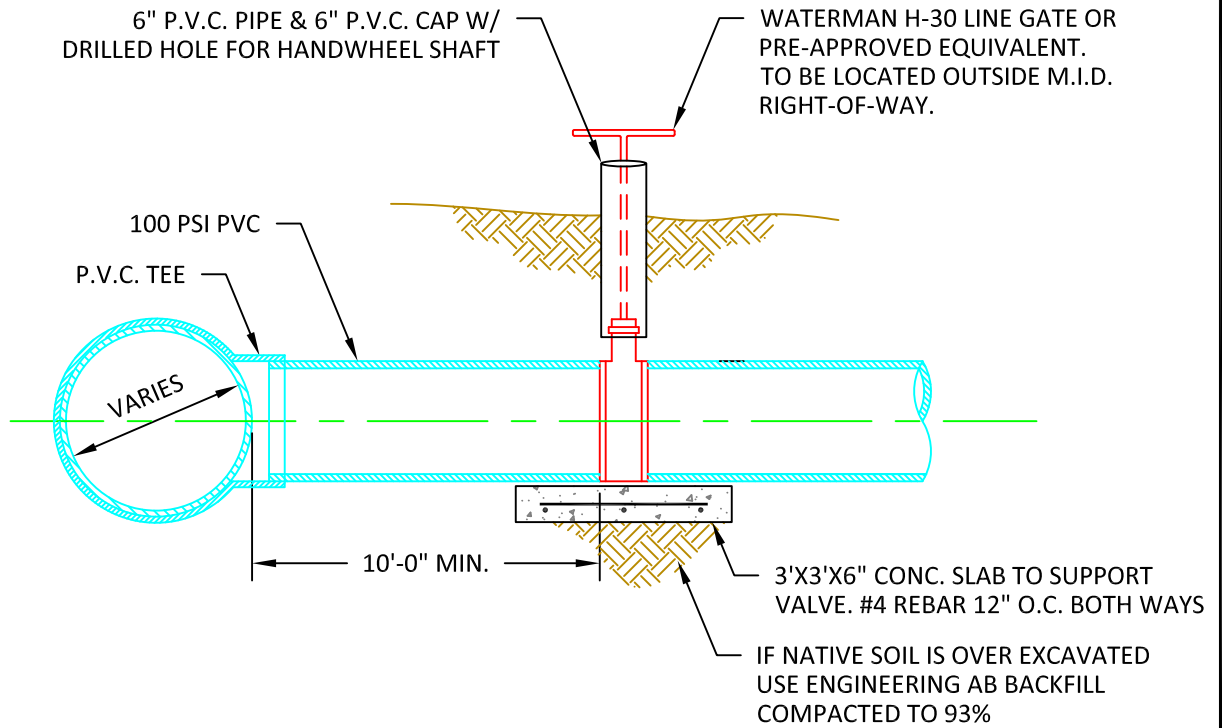

**SECTION VIEW**

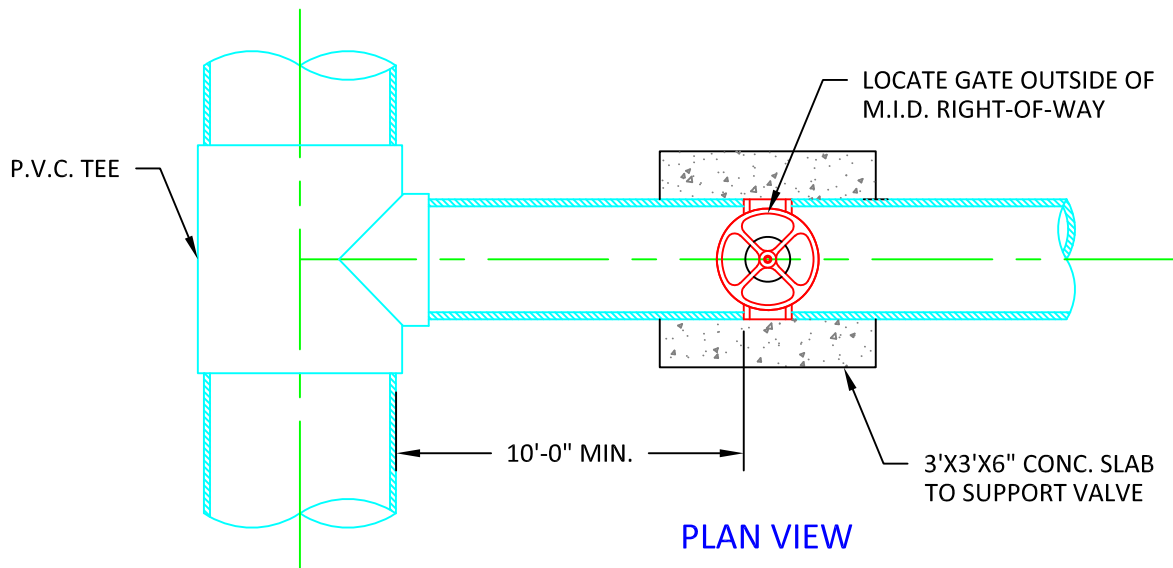

**PLAN VIEW**



**LINE GATE STRUCTURE  
FOR P.V.C. PIPELINE**

DATE: APRIL 2022

STANDARD #:

V 40

SCALE: NONE

APPROVED BY:

*David B. Bakker*

DAVID B. BAKKER, P.E.  
SENIOR CIVIL ENGINEER

DATE: 4/29/22

**NOTES:**

1. CONCRETE STRENGTH TO BE 3,000 PSI @ 28 DAYS. NO ADMIXTURES SHALL BE INCORPORATED INTO CONCRETE MIX UNLESS PRE-APPROVED BY M.I.D. SEE M.I.D. STANDARD G 04 - CONCRETE NOTES\*.
2. ALL PIPE SHALL ENTER STRUCTURE AT OR NEAR PERPENDICULAR ANGLES TO THE WALL OF THE STRUCTURE.
3. THOROUGHLY BRUSH ALL DEBRIS AND CLEAN BOTH PIPE AND STRUCTURE AROUND THE ENTIRE CIRCUMFERENCE WITH WATER PRIOR TO PLACEMENT OF CONCRETE OR MORTAR.
4. MINIMUM #4 BARS FOR ALL COLLAR REINFORCEMENT.
5. A MINIMUM OF TWO CIRCUMFERENCE BARS REQUIRED WITH A MINIMUM 18" BAR LAP. THE BARS MUST HAVE A MINIMUM OF 3" CLEAR FROM PIPE O.D. AND 2" MINIMUM OF CONCRETE COVER.
6. HORIZONTAL BARS SHALL BE PLACED AT 12" O.C. EQUALLY SPACED AROUND THE CIRCUMFERENCE OF THE PIPE WITH A MINIMUM OF SIX (6) HORIZONTAL BARS.
7. PROPERLY SEAL CONNECTION BY MORTARING FROM INSIDE PIPELINE AFTER PERMANENT PLACEMENT OF CONCRETE COLLAR. A MINIMUM MORTARED BAND WIDTH OF 5" IS REQUIRED. USE SOFT BRISTLE BRUSH TO BLEND MORTAR AND CONCRETE TOGETHER. SEE M.I.D. STANDARD G 11 - M.I.D. MORTAR MIX NOTES\*.

REV	CHANGE	DATE	BY
1	RELEASE	04/22	LH
2			
3			
4			

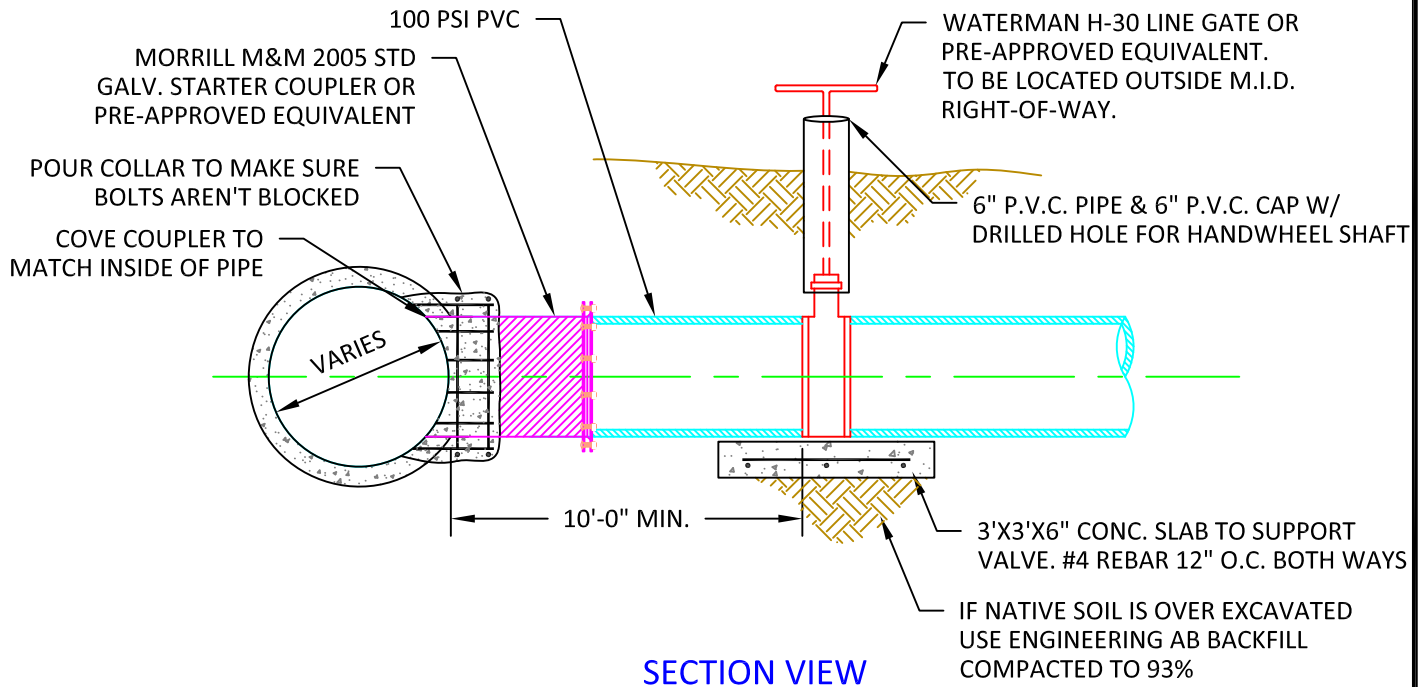

**SECTION VIEW**

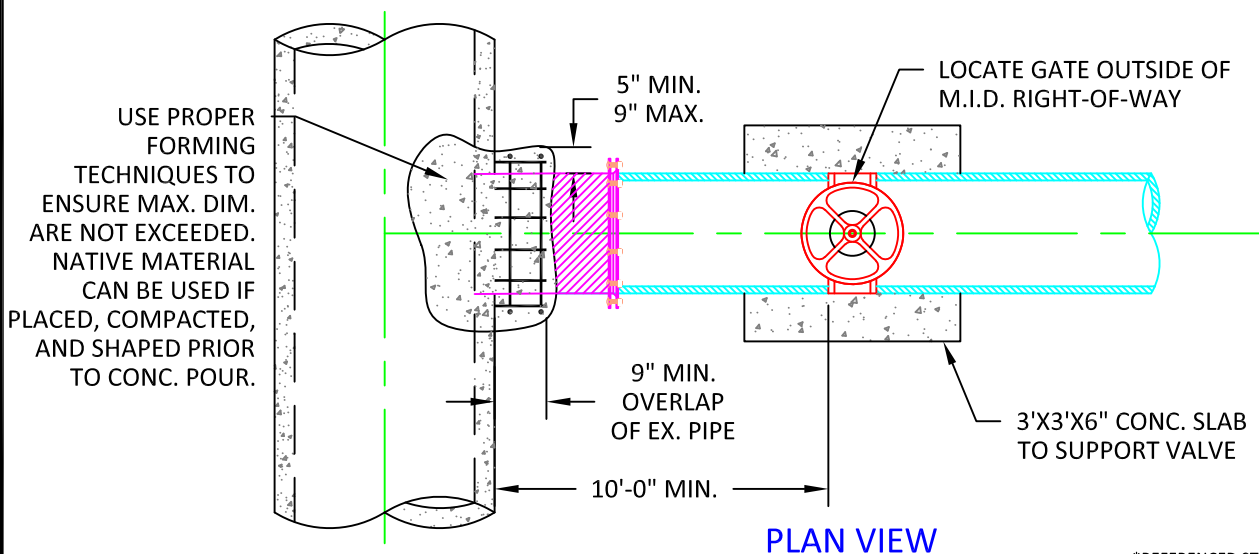

**PLAN VIEW**

\*REFERENCED STANDARD(S): G 04, G 11



**LINE GATE STRUCTURE FOR CONCRETE PIPELINE**

DATE: APRIL 2022

STANDARD #:

V 41

SCALE: NONE

APPROVED BY:

*David B. Bakker*

DAVID B. BAKKER, P.E.  
SENIOR CIVIL ENGINEER

DATE: 4/29/22



**NOTES:**

1. CONCRETE STRENGTH TO BE 3,000 PSI @ 28 DAYS. NO ADMIXTURES SHALL BE INCORPORATED INTO CONCRETE MIX UNLESS PRE-APPROVED BY M.I.D. SEE M.I.D. STANDARD G 04 - CONCRETE NOTES\*.
2. ALL PIPE SHALL ENTER STRUCTURE AT OR NEAR PERPENDICULAR ANGLES TO THE WALL OF THE STRUCTURE.
3. THOROUGHLY BRUSH ALL DEBRIS AND CLEAN BOTH PIPE AND STRUCTURE AROUND THE ENTIRE CIRCUMFERENCE WITH WATER PRIOR TO PLACEMENT OF CONCRETE OR MORTAR.
4. MINIMUM #4 BARS FOR ALL COLLAR REINFORCEMENT.
5. A MINIMUM OF TWO CIRCUMFERENCE BARS REQUIRED WITH A MINIMUM 18" BAR LAP. THE BARS MUST HAVE A MINIMUM OF 3" CLEAR FROM PIPE O.D. AND 2" MINIMUM OF CONCRETE COVER.
6. HORIZONTAL BARS SHALL BE PLACED AT 12" O.C. EQUALLY SPACED AROUND THE CIRCUMFERENCE OF THE PIPE WITH A MINIMUM OF SIX (6) HORIZONTAL BARS.
7. PROPERLY SEAL CONNECTION BY MORTARING FROM INSIDE PIPELINE AFTER PERMANENT PLACEMENT OF CONCRETE COLLAR. A MINIMUM MORTARED BAND WIDTH OF 5" IS REQUIRED. USE SOFT BRISTLE BRUSH TO BLEND MORTAR AND CONCRETE TOGETHER. SEE M.I.D. STANDARD G 11 - M.I.D. MORTAR MIX NOTES\*.
8. USE WELD-ON P-68 PURPLE PRIMER AND WELD-ON 2717 HIGH STRENGTH SOLVENT CEMENT OR PRE-APPROVED EQUIVALENT FOR CEMENTING PIPE AND CONNECTIONS FOR P.V.C. PIPELINE.
9. USE WELD-ON 810 2-PART ADHESIVE TO ATTACH VALVE TO P.V.C. PIPELINE.

REV	CHANGE	DATE	BY
1	RELEASE	06/17	LH
2	REVISED	04/22	LH
3			
4			

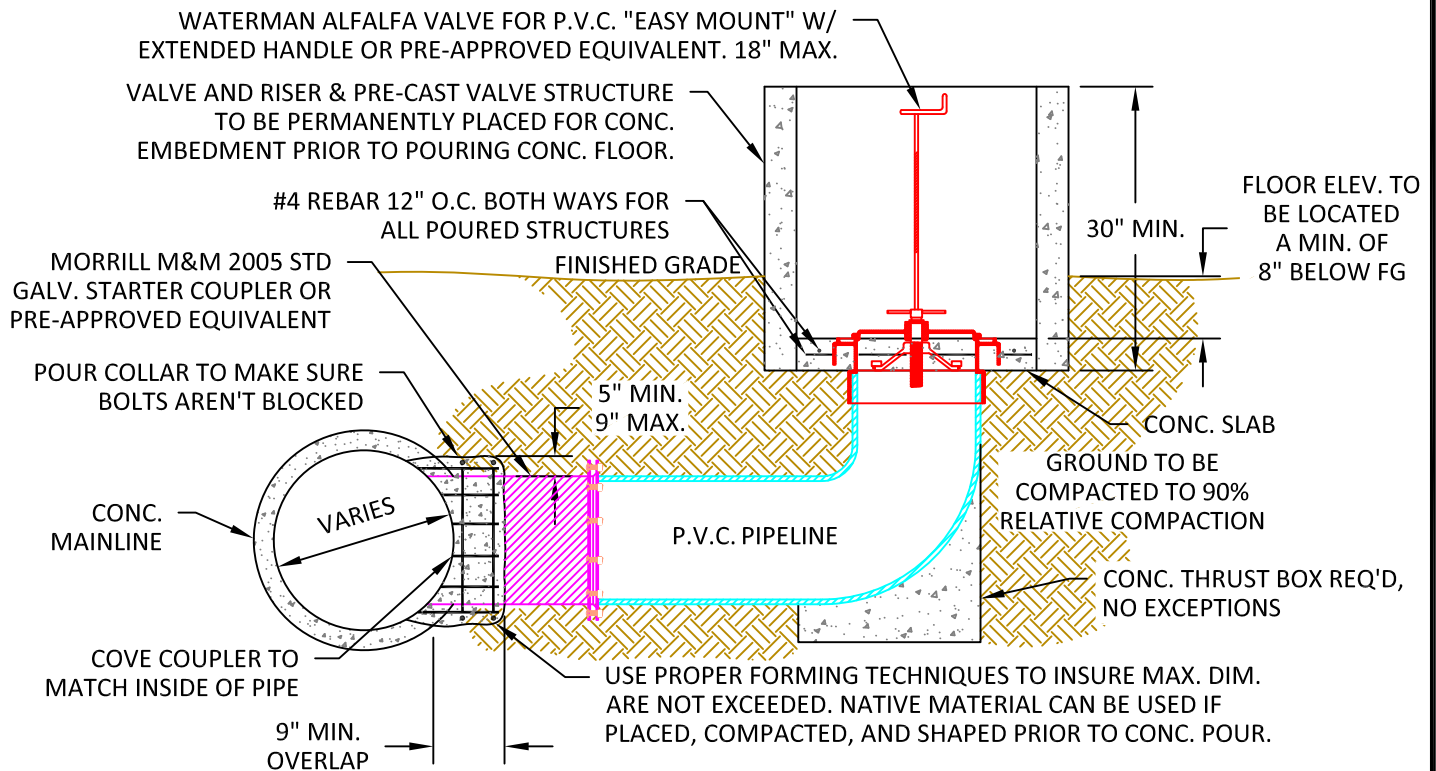

**P.V.C. TO CONCRETE CONNECTION**

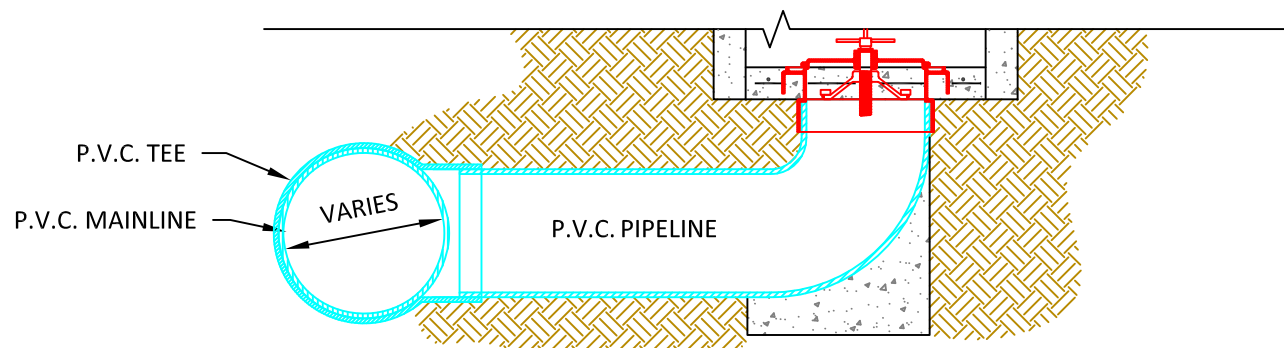

**P.V.C. TO P.V.C. CONNECTION**

\*REFERENCED STANDARD(S): G 04, G 11



OFFSET - ARCH / ALFALFA VALVE STRUCTURE

DATE: JUNE 2017

STANDARD #:

V 45

SCALE: NONE

APPROVED BY:

*David B. Bakker*

DAVID B. BAKKER, P.E.  
SENIOR CIVIL ENGINEER

DATE: 4/29/22